

2 0 1 3 - 2 0 1 7

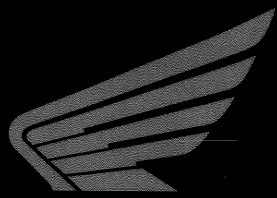

**HONDA**

**SERVICE MANUAL**

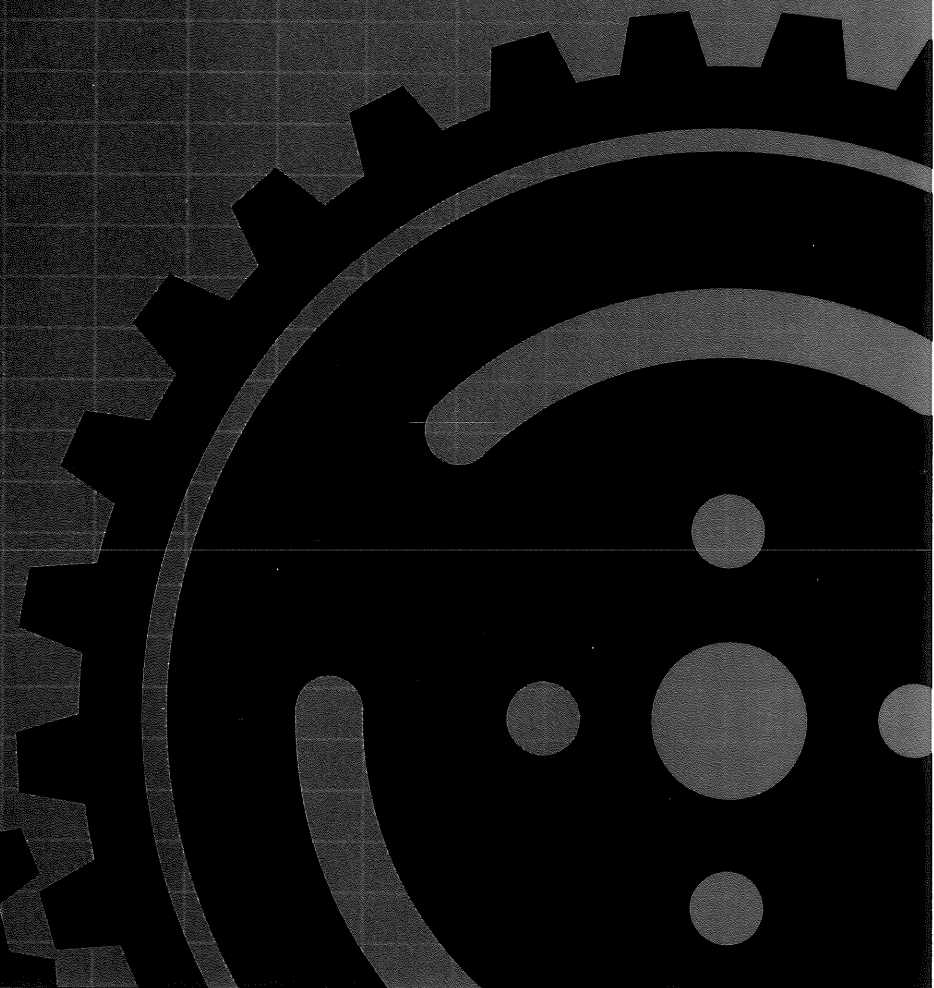

**PCX150**





## How To Use This Manual

This manual describes the service procedures for the PCX150.

Sections 1 and 3 apply to the whole scooter. Section 2 illustrates procedures for removal/installation of components that may be required to perform service described in the following sections.

Section 4 through 21 describe parts of the scooter, grouped according to location.

Follow the Maintenance Schedule recommendations to ensure that the vehicle is in peak operating condition.

Performing the first scheduled maintenance is very important. It compensates for the initial wear that occurs during the break-in period.

Find the section you want on this page, then turn to the table of contents on the first page of the section.

Most sections start with an assembly or system illustration, service information and troubleshooting for the section. The subsequent pages give detailed procedure.

Your safety, and the safety of others, is very important. To help you make informed decisions we have provided safety messages and other information throughout this manual. Of course, it is not practical or possible to warn you about all the hazards associated with servicing this vehicle.

You must use your own good judgement.

You will find important safety information in a variety of forms including:

- Safety Labels – on the vehicle
- Safety Messages – preceded by a safety alert symbol  and one of three signal words, DANGER, WARNING, or CAUTION. These signal words mean:

** DANGER** You WILL be KILLED or SERIOUSLY HURT if you don't follow instructions.

** WARNING** You CAN be KILLED or SERIOUSLY HURT if you don't follow instructions.

** CAUTION** You CAN be HURT if you don't follow instructions.

- Instructions – how to service this vehicle correctly and safely.

As you read this manual, you will find information that is preceded by a ** NOTICE** symbol. The purpose of this message is to help prevent damage to your vehicle, other property, or the environment.



## CONTENTS

	GENERAL INFORMATION	1
	FRAME/BODY PANELS/EXHAUST SYSTEM	2
	MAINTENANCE	3
ENGINE/DRIVE TRAIN ELECTRICAL	PGM-FI SYSTEM	4
	IGNITION SYSTEM	5
	ELECTRIC STARTER	6
	FUEL SYSTEM	7
	LUBRICATION SYSTEM	8
	COOLING SYSTEM	9
	CYLINDER HEAD/VALVES	10
	CYLINDER/PISTON	11
	DRIVE PULLEY/DRIVEN PULLEY/CLUTCH	12
	FINAL REDUCTION	13
	ALTERNATOR/STARTER	14
	CRANKCASE/CRANKSHAFT	15
	ENGINE REMOVAL/INSTALLATION	16
	CHASSIS	FRONT WHEEL/SUSPENSION/STEERING
REAR WHEEL/BRAKE/SUSPENSION		18
HYDRAULIC BRAKE		19
FRAME ELECTRICAL	BATTERY/CHARGING SYSTEM	20
	LIGHTS/METERS/SWITCHES	21
	WIRING DIAGRAM	22
	INDEX	

---

**MEMO**

---

# 1. GENERAL INFORMATION

---



SERVICE RULES.....	1-2	CABLE & HARNESS ROUTING ( '13 MODEL).....	1-19
MODEL IDENTIFICATION .....	1-3	CABLE & HARNESS ROUTING (AFTER '13 MODEL) .....	1-25
SPECIFICATIONS.....	1-6	TECHNICAL FEATURE (AFTER '13 MODEL) .....	1-34
TORQUE VALUES .....	1-11	EMISSION CONTROL SYSTEMS .....	1-35
LUBRICATION & SEAL POINTS .....	1-17		

## GENERAL INFORMATION

### SERVICE RULES

1. Use genuine Honda or Honda-recommended parts and lubricants or their equivalents. Parts that do not meet Honda's design specifications may cause damage to the scooter.
2. Use the special tools designed for this product to avoid damage and incorrect assembly.
3. Use only metric tools when servicing the scooter. Metric bolts, nuts and screws are not interchangeable with English fasteners.
4. Install new gaskets, O-rings, cotter pins, and lock plates when reassembling.
5. When tightening bolts or nuts, begin with the larger diameter or inner bolt first. Then tighten to the specified torque diagonally in incremental steps unless a particular sequence is specified.
6. Clean parts in cleaning solvent upon disassembly. Lubricate any sliding surfaces before reassembly.
7. After reassembly, check all parts for proper installation and operation.
8. Route all electrical wires as shown in the Cable and Harness Routing (page 1-19).
9. Do not bend or twist control cables. Damaged control cables will not operate smoothly and may stick or bind.

### ABBREVIATION

Throughout this manual, the following abbreviations are used to identify the respective parts or systems.

Abbrev. term	Full term
CBS	Combined brake system
CKP sensor	Crankshaft Position sensor
DLC	Data Link Connector
DTC	Diagnostic Trouble Code
ECM	Engine Control Module
ECT sensor	Engine Coolant Temperature sensor
EEPROM	Electrically Erasable Programmable Read Only Memory
EVAP	Evaporative Emission
IACV	Idle Air Control Valve
IAT sensor	Intake Air Temperature sensor
MAP sensor	Manifold Absolute Pressure sensor
MCS	Motorcycle Communication System
MIL	Malfunction Indicator Lamp
PGM-FI	Programmed Fuel Injection
SCS connector	Service Check Short connector
TP sensor	Throttle Position sensor
VS sensor	Vehicle Speed sensor

### DESTINATION CODE

Throughout this manual, the following codes are used to identify individual types for each region.

DESTINATION CODE	REGION
AC	50 state (meets California)
CM	Canada

# MODEL IDENTIFICATION

'13 model:

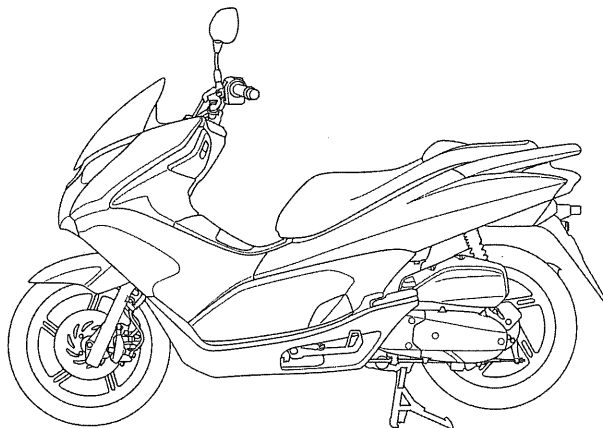

After '13 model:

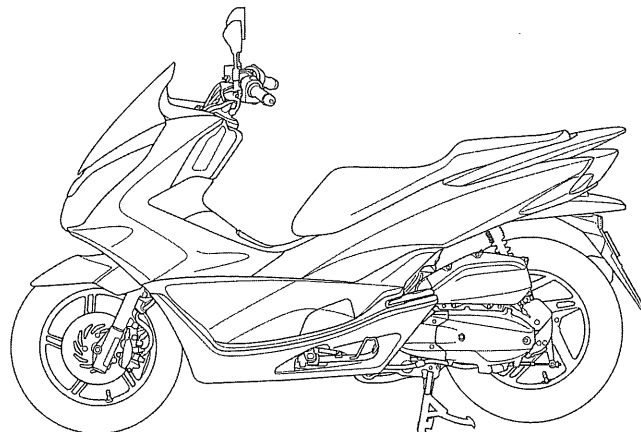

## SERIAL NUMBERS

The Vehicle Identification Number (V.I.N.) [1] is stamped on the seat stay as shown.

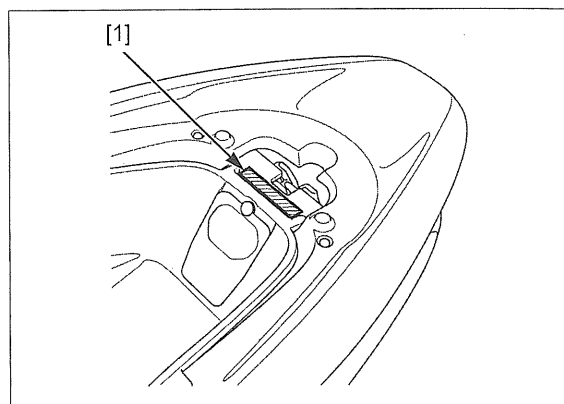

The engine serial number [1] is stamped on the lower left side of the crankcase.

'13 model:

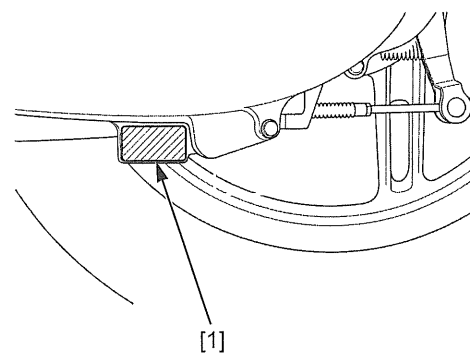

After '13 model:

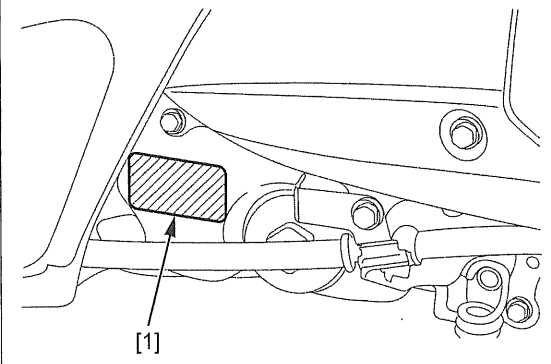

## GENERAL INFORMATION

The throttle body identification number [1] is stamped on the lower side of the throttle body.

'13 model:

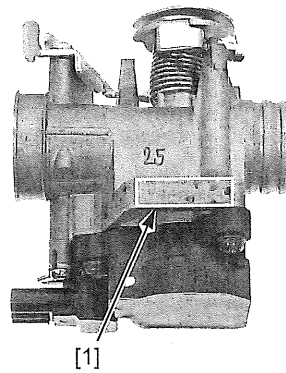

After '13 model:

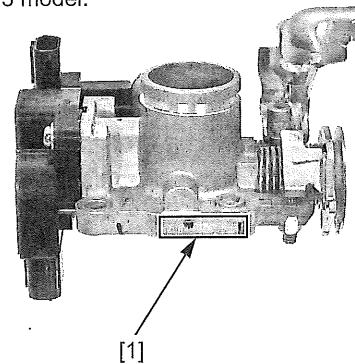

## LABELS

The color label [1] is attached on the inner right side of luggage box. When ordering color-coded parts, always specify the designated color code.

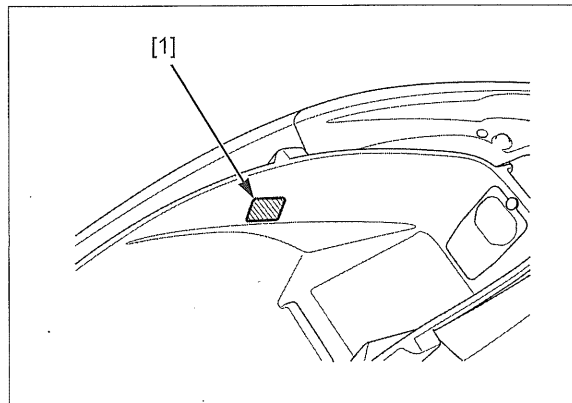

The Emission Control Information Label [1] is attached on the inner left side of luggage box.

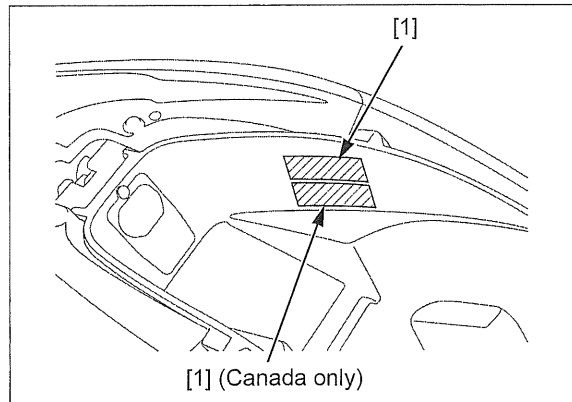



## GENERAL INFORMATION

The Safety Certification Label [1] is attached on the inner cover.

'13 model:

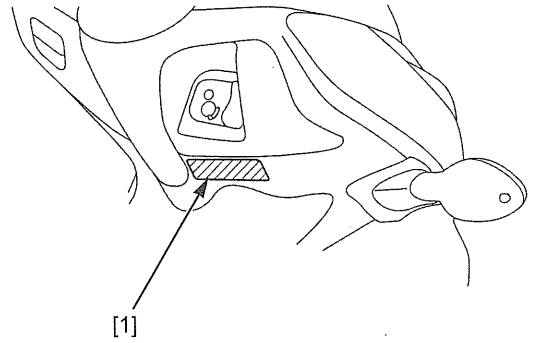

After '13 model:

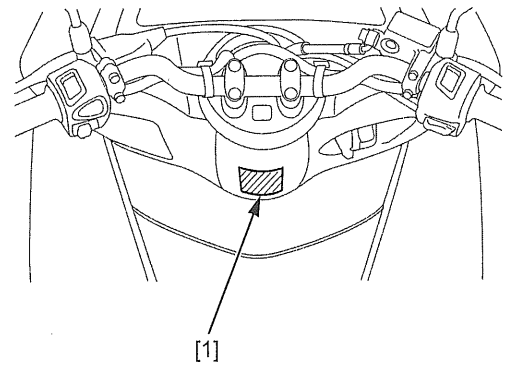

# GENERAL INFORMATION

## SPECIFICATIONS

### GENERAL SPECIFICATIONS ('13 MODEL)

ITEM		SPECIFICATIONS	
DIMENSIONS	Overall length	1,915 mm (75.4 in)	
	Overall width	738 mm (29.1 in)	
	Overall height	1,090 mm (42.9 in)	
	Wheelbase	1,315 mm (51.8 in)	
	Seat height	760 mm (29.9 in)	
	Footpeg height	260 mm (10.2 in)	
	Ground clearance	130 mm (5.1 in)	
	Curb weight	130 kg (287 lbs)	
	Maximum weight capacity	158 kg (348 lbs)	
FRAME	Frame type	Under bone type	
	Front suspension	Telescopic fork	
	Front axle travel	89 mm (3.5 in)	
	Rear suspension	Unit swing	
	Rear axle travel	79 mm (3.1 in)	
	Front tire size	90/90-14M/C 46P	
	Rear tire size	100/90-14M/C 57P	
	Tire brand	Front	SS-560F (IRC)
			TT900F (DUNLOP)
		Rear	SS-560R (IRC)
			TT900A (DUNLOP)
	Front brake	Hydraulic disc brake	
	Rear brake	Mechanical leading trailing	
	Caster angle	27°00'	
	Trail length	86 mm (3.4 in)	
Fuel tank capacity	5.9 liter (1.56 US gal, 1.30 Imp gal)		
ENGINE	Bore and stroke	58.0 x 57.9 mm (2.28 x 2.28 in)	
	Displacement	153 cm <sup>3</sup> (9.3 cu-in)	
	Compression ratio	10.6 : 1	
	Valve train	2 valve, single chain driven SOHC	
	Intake valve	opens	at 1 mm (0.04 in) lift
		closes	at 1 mm (0.04 in) lift
	Exhaust valve	opens	at 1 mm (0.04 in) lift
		closes	at 1 mm (0.04 in) lift
	Lubrication system	Forced pressure and wet sump	
	Oil pump type	Trochoid	
	Cooling system	Liquid cooled	
	Air filtration	Viscous paper filter	
Engine dry weight	30.1 kg (66.4 lbs)		
FUEL DELIVERY SYSTEM	Type	PGM-FI (Programmed Fuel Injection)	
	Throttle bore	26 mm (1.0 in)	
DRIVE TRAIN	Clutch system	Dry, automatic centrifugal clutch	
	Drive belt ratio	2.45 : 1 - 0.81 : 1	
	Final reduction	10.552 (53/17 x 44/13)	
ELECTRICAL	Ignition system	Full transistorized	
	Starting system	Electric starter	
	Charging system	Triple phase output alternator	
	Lighting system	Battery	

GENERAL SPECIFICATIONS (AFTER '13 MODEL)

ITEM		SPECIFICATIONS	
DIMENSIONS	Overall length	1,931 mm (76.0 in)	
	Overall width	737 mm (29.0 in)	
	Overall height	1,103 mm (43.4 in)	
	Wheelbase	1,315 mm (51.8 in)	
	Seat height	761 mm (30.0 in)	
	Footpeg height	260 mm (10.2 in)	
	Ground clearance	138 mm (5.4 in)	
	Curb weight	AC type	134 kg (295.4 lbs)
		CM type	133 kg (295.4 lbs)
Maximum weight capacity	161 kg (354.9 lbs)		
FRAME	Frame type	Under bone type	
	Front suspension	Telescopic fork	
	Front axle travel	89 mm (3.5 in)	
	Rear suspension	Unit swing	
	Rear axle travel	79 mm (3.1 in)	
	Front tire size	90/90-14M/C 46P	
	Rear tire size	100/90-14M/C 57P	
	Tire brand	Front	SS-560F (IRC)
		Rear	SS-560R <sub>b</sub> (IRC)
	Front brake	Hydraulic disc brake	
	Rear brake	Mechanical leading trailing	
	Caster angle	27°00'	
	Trail length	86 mm (3.4 in)	
	Fuel tank capacity	8.0 liter (2.11 US gal, 1.76 Imp gal)	
ENGINE	Bore and stroke	58.0 x 57.9 mm (2.28 x 2.28 in)	
	Displacement	153 cm <sup>3</sup> (9.3 cu-in)	
	Compression ratio	10.6 : 1	
	Valve train	2 valve, single chain driven SOHC	
	Intake valve	opens	at 1 mm (0.04 in) lift
		closes	at 1 mm (0.04 in) lift
	Exhaust valve	opens	at 1 mm (0.04 in) lift
		closes	at 1 mm (0.04 in) lift
	Lubrication system	Forced pressure and wet sump	
	Oil pump type	Trochoid	
	Cooling system	Liquid cooled	
Air filtration	Viscous paper filter		
Engine dry weight	30.0 kg (66.1 lbs)		
FUEL DELIVERY SYSTEM	Type	PGM-FI (Programmed Fuel Injection)	
	Throttle bore	26 mm (1.0 in)	
DRIVE TRAIN	Clutch system	Dry, automatic centrifugal clutch	
	Drive belt ratio	2.4 : 1 - 0.80 : 1	
	Final reduction	10.751 (54/17 x 44/13)	
ELECTRICAL	Ignition system	Full transistorized	
	Starting system	Electric starter	
	Charging system	Triple phase output alternator	
	Lighting system	Battery	

## GENERAL INFORMATION

### PGM-FI SYSTEM SPECIFICATIONS

ITEM		SPECIFICATIONS
Engine idle speed		1,700 ± 100 rpm
ECT sensor resistance	(40°C/104°F)	1.0 – 1.3 kΩ
	(100°C/212°F)	0.1 – 0.2 kΩ
Fuel injector resistance (20°C/68°F)		11 – 13 Ω

### IGNITION SYSTEM SPECIFICATIONS

ITEM		SPECIFICATIONS
Spark plug		CPR7EA-9 (NGK)
Spark plug gap		0.8 – 0.9 mm (0.03 – 0.04 in)
Ignition coil peak voltage		100 V minimum
Ignition timing		12° BTDC at idle speed

### FUEL SYSTEM SPECIFICATIONS

ITEM		SPECIFICATIONS
Throttle body identification number	'13 model	GQMHA
	After '13 model	GQMNA
Throttle grip freeplay		2 – 6 mm (0.1 – 0.2 in)
Fuel pressure at idle	'13 model	294 kPa (3.0 kgf/cm <sup>2</sup> , 43 psi)
	After '13 model	263 – 316 kPa (2.7 – 3.2 kgf/cm <sup>2</sup> , 38 – 46 psi)
Fuel pump flow (at 12 V)	'13 model	98 cm <sup>3</sup> (3.31 US oz, 3.45 Imp oz) minimum/10 seconds
	After '13 model	82 cm <sup>3</sup> (2.77 US oz, 2.89 Imp oz) minimum/10 seconds

### LUBRICATION SYSTEM SPECIFICATIONS

Unit: mm (in)

ITEM		STANDARD	SERVICE LIMIT
Engine oil capacity	After draining	0.8 liter (0.8 US qt, 0.7 Imp qt)	–
	After disassembly	0.9 liter (1.0 US qt, 0.8 Imp qt)	–
	After oil strainer removal	0.9 liter (1.0 US qt, 0.8 Imp qt)	–
Recommended engine oil		Pro Honda HP4M 4-stroke oil (U.S.A. and Canada) or equivalent motor oil API service classification: SJ or higher JASO T 903 standard: MB Viscosity: SAE 10W-30	–
Oil pump rotor	Oil pump body I.D.	23.150 – 23.180 (0.9114 – 0.9126)	–
	Outer rotor O.D.	22.970 – 23.000 (0.9043 – 0.9055)	–
	Body-to-outer rotor clearance	0.15 – 0.21 (0.0059 – 0.0083)	0.35 (0.014)
	Oil pump body depth	7.020 – 7.090 (0.2764 – 0.2791)	–
	Outer rotor height	6.960 – 6.980 (0.2740 – 0.2748)	–
	Side clearance	0.040 – 0.130 (0.0016 – 0.0051)	0.15 (0.006)

### COOLING SYSTEM SPECIFICATIONS

ITEM		SPECIFICATIONS
Coolant capacity	Radiator and engine	
	Reserve tank	'13 model
		After '13 model
Radiator cap relief pressure		108 – 137 kPa (1.1 – 1.4 kgf/cm <sup>2</sup> , 16 – 20 psi)
Thermostat	Begin to open	'13 model
		After '13 model
	Fully open	'13 model
		After '13 model
	Valve lift	'13 model
		After '13 model
Recommended antifreeze		Pro Honda HP Coolant or an equivalent high quality ethylene glycol antifreeze containing silicate-free corrosion inhibitors
Standard coolant concentration		1:1 (mixture with distilled water)

**CYLINDER HEAD/VALVES SPECIFICATIONS**

Unit: mm (in)

ITEM		STANDARD	SERVICE LIMIT
Cylinder compression		1,098 kPa (11.2 kgf/cm <sup>2</sup> , 159.3 psi) at 850 rpm	-
Cylinder head warpage		-	0.05 (0.002)
Rocker arm shaft O.D.		IN/EX 9.960 – 9.972 (0.3921 – 0.3926)	-
Camshaft	Cam lobe height	IN 33.616 – 33.856 (1.3235 – 1.3329)	-
		EX 33.393 – 33.633 (1.3147 – 1.3241)	-
Valve, valve guide	Valve clearance	IN 0.10 ± 0.02 (0.004 ± 0.001)	-
		EX 0.24 ± 0.02 (0.009 ± 0.001)	-
	Valve stem O.D.	IN 4.975 – 4.990 (0.1959 – 0.1965)	4.90 (0.193)
		EX 4.955 – 4.970 (0.1951 – 0.1957)	4.90 (0.193)
	Valve guide I.D.	IN/EX 5.000 – 5.012 (0.1969 – 0.1973)	5.03 (0.198)
	Stem-to-guide clearance	IN 0.010 – 0.037 (0.0004 – 0.0015)	0.08 (0.003)
		EX 0.030 – 0.057 (0.0012 – 0.0022)	0.10 (0.004)
	Valve guide projection above cylinder head	IN/EX 11.05 – 11.35 (0.435 – 0.447)	-
Valve seat width	IN/EX 0.90 – 1.10 (0.035 – 0.043)	1.5 (0.06)	
Valve spring free length		IN/EX 36.94 (1.454)	-

**CYLINDER/PISTON SPECIFICATIONS**

Unit: mm (in)

ITEM		STANDARD	SERVICE LIMIT	
Cylinder	I.D.	58.000 – 58.010 (2.2835 – 2.2839)	-	
	Out-of-round	-	0.05 (0.002)	
	Taper	-	0.05 (0.002)	
	Warpage	-	0.05 (0.002)	
Piston, piston rings, piston pin	Piston O.D.	57.970 – 57.990 (2.2822 – 2.2831)	-	
	Piston O.D. measurement point	6.5 (0.26) from bottom of skirt	-	
	Piston pin bore I.D.	14.002 – 14.008 (0.5513 – 0.5515)	14.04 (0.553)	
	Piston pin O.D.	13.994 – 14.000 (0.5509 – 0.5512)	13.96 (0.550)	
	Piston-to-piston pin clearance	0.002 – 0.014 (0.0001 – 0.0006)	0.02 (0.001)	
	Piston ring-to-ring groove clearance	Top	0.015 – 0.055 (0.0006 – 0.0022)	0.08 (0.003)
		Second	0.015 – 0.055 (0.0006 – 0.0022)	0.08 (0.003)
	Piston ring end gap	Top	0.10 – 0.25 (0.004 – 0.0010)	0.45 (0.018)
		Second	0.38 – 0.52 (0.015 – 0.0020)	-
Oil (side rail)		0.20 – 0.70 (0.008 – 0.028)	-	
Cylinder-to-piston clearance		0.01 – 0.04 (0.0004 – 0.0016)	0.09 (0.004)	
Connecting rod small end I.D.		14.010 – 14.028 (0.5516 – 0.5523)	14.06 (0.554)	
Connecting rod-to-piston pin clearance		0.010 – 0.034 (0.0004 – 0.0013)	0.05 (0.002)	

**DRIVE PULLEY/DRIVEN PULLEY/CLUTCH SPECIFICATIONS**

Unit: mm (in)

ITEM		STANDARD	SERVICE LIMIT
Drive belt width	'13 model	22.0 (0.87)	21.0 (0.83)
	After '13 model	22.6 (0.89)	21.6 (0.85)
Movable drive face	Bushing I.D.	23.989 – 24.052 (0.9444 – 0.9469)	24.08 (0.948)
	Boss O.D.	23.960 – 23.974 (0.9433 – 0.9439)	23.93 (0.942)
	Weight roller O.D.	19.92 – 20.08 (0.784 – 0.791)	19.5 (0.77)
Clutch	Lining thickness	-	2.0 (0.08)
	Clutch outer I.D.	125.0 – 125.2 (4.92 – 4.93)	125.5 (4.94)
Driven pulley	Face spring free length	151.1 (5.95)	146.6 (5.77)
	Driven face O.D.	33.965 – 33.985 (1.3372 – 1.3380)	33.94 (1.336)
	Movable driven face I.D.	34.000 – 34.025 (1.3386 – 1.3396)	34.06 (1.341)

## GENERAL INFORMATION

### FINAL REDUCTION SPECIFICATIONS

ITEM		SPECIFICATIONS
Final reduction oil capacity	After draining	0.12 liter (0.13 US qt, 0.11 Imp qt)
	After disassembly	0.14 liter (0.15 US qt, 0.12 Imp qt)
Recommended final reduction oil		Pro Honda HP4M 4-stroke oil (U.S.A. and Canada) or equivalent motor oil API service classification: SJ or higher JASO T 903 standard: MB Viscosity: SAE 10W-30

### CRANKCASE/CRANKSHAFT SPECIFICATIONS

Unit: mm (in)

ITEM		STANDARD	SERVICE LIMIT
Crankshaft	Connecting rod side clearance	0.10 – 0.35 (0.004 – 0.014)	0.55 (0.022)
	Connecting rod radial clearance	0.004 – 0.016 (0.0002 – 0.0006)	0.05 (0.002)
	Runout	–	0.10 (0.004)

### FRONT WHEEL/SUSPENSION/STEERING SPECIFICATIONS

Unit: mm (in)

ITEM		STANDARD	SERVICE LIMIT
Minimum tire tread depth		–	1.5 (0.06)
Cold tire pressure	Up to 90 kg (200 lbs) load	200 kPa (2.00 kgf/cm <sup>2</sup> , 29 psi)	–
	Up to maximum weight capacity	200 kPa (2.00 kgf/cm <sup>2</sup> , 29 psi)	–
Axle runout		–	0.2 (0.01)
Wheel rim runout	Radial	–	2.0 (0.08)
	Axial	–	2.0 (0.08)
Fork	Spring free length	291.8 (11.49)	–
	Pipe runout	–	0.2 (0.01)
	Recommended fluid	Pro Honda Suspension Fluid SS-8 (10W) or equivalent	–
	Fluid level	75 (2.95)	–
	Fluid capacity	122.0 ± 2.5 cm <sup>3</sup> (4.13 ± 0.05 US oz, 4.29 ± 0.05 Imp oz)	–

### REAR WHEEL/BRAKE/SUSPENSION SPECIFICATIONS

Unit: mm (in)

ITEM		STANDARD	SERVICE LIMIT
Minimum tire tread depth		–	2.0 (0.08)
Cold tire pressure	Up to 90 kg (200 lbs) load	225 kPa (2.25 kgf/cm <sup>2</sup> , 33 psi)	–
	Up to maximum weight capacity	250 kPa (2.50 kgf/cm <sup>2</sup> , 36 psi)	–
Wheel rim runout	Radial	–	2.0 (0.08)
	Axial	–	2.0 (0.08)
Brake	Brake lever freeplay	10 – 20 (0.4 – 0.8)	–
	Brake drum I.D.	130.0 – 130.2 (5.12 – 5.13)	131.0 (5.16)

### HYDRAULIC BRAKE SPECIFICATIONS

Unit: mm (in)

ITEM		STANDARD	SERVICE LIMIT
Specified brake fluid		DOT 3 or 4	–
Brake disc	Thickness	3.5 ± 0.2 (0.14 ± 0.008)	3.0 (0.12)
	Warpage	–	0.30 (0.001)
Front brake master cylinder	Cylinder I.D.	12.700 – 12.743 (0.5000 – 0.5017)	12.755 (0.5022)
	Piston O.D.	12.657 – 12.684 (0.4983 – 0.4994)	12.645 (0.4978)
CBS master cylinder	Cylinder I.D.	11.000 – 11.043 (0.4331 – 0.4348)	11.055 (0.4352)
	Piston O.D.	10.957 – 10.984 (0.4314 – 0.4324)	10.945 (0.4309)
Caliper	Cylinder I.D.	Upper	25.400 – 25.450 (1.0000 – 1.0020)
		Center/lower	22.650 – 22.700 (0.8917 – 0.8937)
	Piston O.D.	Upper	25.318 – 25.368 (0.9968 – 0.9987)
		Center/Lower	22.585 – 22.618 (0.8892 – 0.8905)

**BATTERY/CHARGING SYSTEM SPECIFICATIONS**

ITEM			SPECIFICATIONS
Battery	Type	'13 model	YTZ7S
		After '13 model	GTZ8V
	Capacity	'13 model	12 V – 6 Ah (10HR)
		After '13 model	12 V – 7 Ah (10HR)
	Current leakage	'13 model	0.1 mA max.
		After '13 model	0.4 mA max.
	Voltage	Fully charged	13.0 – 13.2 V
		Needs charging	Below 12.4 V
	Charging current	Normal	'13 model
After '13 model			0.5 A/5 – 10 h
Quick		'13 model	3 A/1 h
		After '13 model	2.5 A/1 h
Alternator	Capacity		0.343 kW/5,000 rpm

**LIGHTS/METERS/SWITCHES SPECIFICATIONS**

ITEM			SPECIFICATIONS
Bulbs	Headlight	'13 model	12 V – 35/30 W x 2
		After '13 model	LED
	Accessory light (After '13 model)		LED
	Tail/brake light	'13 model	12 V – 5 W/21 W
		After '13 model	LED
	License light	'13 model	12 V – 5 W
		After '13 model	LED
	Front turn signal light	'13 model	12 V – 21 W x 2
		After '13 model	LED
	Rear turn signal light	'13 model	12 V – 21 W x 2
		After '13 model	LED
	Instrument light		LED
	PGM-FI malfunction indicator lamp (MIL)		LED
	High beam indicator		LED
Turn signal indicator		LED	
Coolant temperature indicator		LED	
Fuse	Main fuse 1 ('13 model)		10 A
	Main fuse 2 ('13 model)		30 A
	Main fuse (After '13 model)		25 A
	Sub fuse	'13 model	10 A x 3, 15 A x 1
After '13 model		5 A, 10 A x 4	

**TORQUE VALUES**

**STANDARD TORQUE VALUES**

FASTENER TYPE	TORQUE N·m (kgf·m, lbf·ft)	FASTENER TYPE	TORQUE N·m (kgf·m, lbf·ft)
5 mm hex bolt and nut	5.2 (0.5, 3.8)	5 mm screw	4.2 (0.4, 3.1)
6 mm hex bolt and nut (Include SH flange bolt)	10 (1.0, 7)	6 mm screw	9.0 (0.9, 6.6)
		6 mm flange bolt (Include NSHF) and nut	12 (1.2, 9)
8 mm hex bolt and nut	22 (2.2, 16)	8 mm flange bolt and nut	27 (2.8, 20)
10 mm hex bolt and nut	34 (3.5, 25)		
12 mm hex bolt and nut	54 (5.5, 40)	10 mm flange bolt and nut	39 (4.0, 29)

**ENGINE & FRAME TORQUE VALUES**

- Torque specifications listed below are for specified fasteners.
- Others should be tightened to standard torque values listed above.

## GENERAL INFORMATION

### FRAME/BODY PANELS/EXHAUST SYSTEM

ITEM	Q'TY	THREAD DIA. (mm)	TORQUE N·m (kgf·m, lbf·ft)	REMARKS
Front reflex reflector mounting nut ('13 model)	2	6	1.5 (0.15, 1.1)	U-nut
Front turn signal light unit mounting nut ('13 model)	2	6	8.8 (0.9, 6.5)	U-nut
Tail/brake light unit mounting screw ('13 model)	4	4	1 (0.1, 0.7)	
Rear combination light unit mounting screw (After '13 model)	5	5	1.2 (0.12, 0.9)	
Luggage box nut (After '13 model)	2	6	3 (0.3, 2.2)	
Exhaust pipe joint nut	2	7	29 (3.0, 21)	For tightening sequence; See page 2-28
Muffler protector mounting bolt	2	6	10 (1.0, 7)	
Muffler mounting bolt	3	10	49 (5.0, 36)	For tightening sequence; See page 2-28
Exhaust pipe stud bolt	2	7	-	See page 2-28

### MAINTENANCE

ITEM	Q'TY	THREAD DIA. (mm)	TORQUE N·m (kgf·m, lbf·ft)	REMARKS
Spark plug	1	10	16 (1.6, 12)	
Valve adjusting screw lock nut	2	5	10 (1.0, 7)	Apply oil to the threads and seating surface.
Engine oil drain bolt	1	12	24 (2.4, 18)	
Engine oil strainer screen cap	1	30	20 (2.0, 15)	
Final reduction oil check bolt	1	8	23 (2.3, 17)	
Final reduction oil drain bolt	1	8	23 (2.3, 17)	
Air cleaner housing cover screw	7	5	1.1 (0.11, 0.8)	
1st rear brake cable lock nut	1	8	6.5 (0.66, 4.8)	
Brake lock cable lock nut	2	6	3 (0.31, 2.2)	

### PGM-FI SYSTEM

ITEM	Q'TY	THREAD DIA. (mm)	TORQUE N·m (kgf·m, lbf·ft)	REMARKS
ECT sensor	1	10	12 (1.2, 9)	
O <sub>2</sub> sensor	1	12	24.5 (2.5, 18)	

### ELECTRIC STARTER

ITEM	Q'TY	THREAD DIA. (mm)	TORQUE N·m (kgf·m, lbf·ft)	REMARKS
Sidestand switch bolt	1	6	10 (1.0, 7)	ALOC bolt: replace a with new one.



## GENERAL INFORMATION

### FUEL SYSTEM

ITEM	Q'TY	THREAD DIA. (mm)	TORQUE N·m (kgf·m, lbf·ft)	REMARKS
Fuel pump set plate nut	4	6	12 (1.2, 9)	For tightening sequence; See page 7-12
Air cleaner housing mounting bolt	2	6	11 (1.1, 8)	
Rear inner fender socket bolt - Air cleaner side	1	6	3.5 (0.36, 2.6)	
Sensor unit torx screw ('13 model)	3	5	3.4 (0.35, 2.5)	
Sensor unit mounting screw ('After 13 model)	2	4	2.1 (0.21, 1.5)	
Throttle cable bracket mounting screw ('13 model)	1	5	3.4 (0.35, 2.5)	
Throttle cable bracket mounting bolt (After '13 model)	1	5	3.4 (0.35, 2.5)	
Throttle cable adjusting lock nut (After '13 model)	1	7	3.8 (0.39, 2.8)	
Throttle cable nut (throttle body side) (After '13 model)	2	8	8.5 (0.87, 6.3)	See page 7-15
IACV torx screw ('13 model)	2	4	2.1 (0.21, 1.5)	
IACV screw (After '13 model)	3	4	2.1 (0.21, 1.5)	
Insulator band bolt	2	5	5 (0.51, 3.7)	

### LUBRICATION SYSTEM

ITEM	Q'TY	THREAD DIA. (mm)	TORQUE N·m (kgf·m, lbf·ft)	REMARKS
Oil pump mounting bolt	2	6	10 (1.0, 7)	

### COOLING SYSTEM

ITEM	Q'TY	THREAD DIA. (mm)	TORQUE N·m (kgf·m, lbf·ft)	REMARKS
Radiator drain bolt	1	10	1 (0.1, 0.7)	
Radiator base screw	1	4	0.8 (0.08, 0.6)	
Radiator top cover screw	4	4	3.2 (0.33, 2.4)	
Radiator distance bolt	4	7	16.5 (1.7, 12)	

### CYLINDER HEAD/VALVES

ITEM	Q'TY	THREAD DIA. (mm)	TORQUE N·m (kgf·m, lbf·ft)	REMARKS
Camshaft stopper bolt	1	6	10 (1.0, 7)	
Rocker arm shaft stopper bolt	2	5	5 (0.51, 3.7)	Apply oil to the threads and seating surface.
Cam sprocket socket bolt	2	5	8 (0.82, 5.9)	Apply oil to the threads and seating surface.
Cam chain tensioner lifter screw	1	6	4 (0.41, 3.0)	
Water pump holder bolt	2	6	10 (1.0, 7)	
Cylinder head nut	4	8	27 (2.8, 20)	Apply oil to the threads and seating surface.
Cylinder head sealing bolt	1	12	32 (3.3, 24)	
Breather separator plate screw	4	4	3.2 (0.33, 2.4)	

### CYLINDER/PISTON

ITEM	Q'TY	THREAD DIA. (mm)	TORQUE N·m (kgf·m, lbf·ft)	REMARKS
Cylinder stud bolt	4	8	-	See page 11-6

### DRIVE PULLEY/DRIVEN PULLEY/CLUTCH

ITEM	Q'TY	THREAD DIA. (mm)	TORQUE N·m (kgf·m, lbf·ft)	REMARKS
Drive pulley face nut	1	14	59 (6.0, 44)	Apply oil to the threads and seating surface.
Clutch/driven pulley nut	1	28	54 (5.5, 40)	
Clutch outer nut	1	12	49 (5.0, 36)	

## GENERAL INFORMATION

### FINAL REDUCTION

ITEM	Q'TY	THREAD DIA. (mm)	TORQUE N·m (kgf·m, lbf·ft)	REMARKS
Final reduction case bolt	6	8	23 (2.3, 17)	
Final reduction oil drain bolt	1	8	23 (2.3, 17)	

### ALTERNATOR/STARTER

ITEM	Q'TY	THREAD DIA. (mm)	TORQUE N·m (kgf·m, lbf·ft)	REMARKS
Stator mounting socket bolt	3	6	10 (1.0, 7)	
CKP sensor mounting special bolt	1	6	10 (1.0, 7)	
Flywheel nut	1	12	69 (7.0, 51)	
Cooling fan mounting bolt	3	6	8.5 (0.87, 6.3)	
Passenger step mounting bolt	4	8	26.5 (2.7, 20)	

### ENGINE REMOVAL/INSTALLATION

ITEM	Q'TY	THREAD DIA. (mm)	TORQUE N·m (kgf·m, lbf·ft)	REMARKS
Engine hanger link pivot nut				
- Frame side	1	10	59 (6.0, 44)	U-nut
- Engine side	1	10	49 (5.0, 36)	U-nut
Shock absorber upper mounting nut	2	10	24 (2.4, 18)	

### FRONT WHEEL/SUSPENSION/STEERING

ITEM	Q'TY	THREAD DIA. (mm)	TORQUE N·m (kgf·m, lbf·ft)	REMARKS
Front brake disc socket bolt	4	8	42 (4.3, 31)	ALOC bolt: replace with new ones.
Front axle nut	1	12	59 (6.0, 44)	U-nut
Fork socket bolt	2	8	20 (2.0, 15)	Apply locking agent to the threads.
Bottom bridge pinch bolt	4	10	49 (5.0, 36)	
Brake caliper mounting bolt	2	8	30 (3.1, 22)	ALOC bolt: replace with new ones.
Handlebar upper holder socket bolt	4	8	27 (2.8, 20)	For tightening sequence; See page 17-20
Right/left handlebar switch housing screw	4	5	2.5 (0.26, 1.8)	
Handlebar weight screw	2	6	9 (0.9, 7)	Apply locking agent to the threads.
Front master cylinder holder socket bolt	2	6	12 (1.2, 9)	
Rear brake lever bracket socket bolt	2	6	12 (1.2, 9)	
Rearview mirror lock nut	2	10	34 (3.5, 25)	Left hand threads.
Handlebar lower holder nut	2	10	44 (4.5, 33)	U-nut
Handlebar post nut	1	10	39 (4.0, 29)	U-nut
Rearview mirror adapter bolt	2	10	34 (3.5, 25)	
Steering stem top thread	1	26	-	See page 17-28
Steering stem lock nut	1	26	-	See page 17-28
Throttle cable lock nut (handlebar side)	1	10	1.5 (0.15, 1.1)	
Rear brake lever pivot bolt	1	5	1 (0.1, 0.7)	
Rear brake lever pivot nut	1	5	4.5 (0.46, 3.3)	U-nut

## GENERAL INFORMATION

### REAR WHEEL/BRAKE/SUSPENSION

ITEM	Q'TY	THREAD DIA. (mm)	TORQUE N·m (kgf·m, lbf·ft)	REMARKS
Rear axle nut	1	16	118 (12.0, 87)	U-nut, Apply oil to the threads and seating surface.
Shock absorber upper mounting nut	2	10	24 (2.4, 18)	
Rear brake arm bolt	1	6	10 (1.0, 7)	ALOC bolt: replace a with new one.
Rear inner fender socket bolt				
- Engine side	1	6	10 (1.0, 7)	
- Air cleaner side	1	6	3.5 (0.36, 2.6)	
Brake shoe anchor pin nut	1	8		
- When using the stake nut			20 (2.0, 15)	
- When using the normal nut			18 (1.8, 13)	

### HYDRAULIC BRAKE

ITEM	Q'TY	THREAD DIA. (mm)	TORQUE N·m (kgf·m, lbf·ft)	REMARKS
Brake caliper bleed valve	2	8	5.4 (0.55, 4.4)	
Front brake master cylinder reservoir cap screw	2	4	1.5 (0.15, 1.1)	
CBS master cylinder reservoir bolt	1	6	6 (0.61, 4.4)	
Front brake light switch screw	1	4	1 (0.1, 0.7)	
Brake pad pin	1	10	18 (1.8, 13)	
Front brake lever pivot bolt	1	6	1 (0.1, 0.7)	
Front brake lever pivot nut	1	6	6 (0.61, 4.4)	
Front master cylinder holder socket bolt	2	6	12 (1.2, 9)	
Brake hose oil bolt	4	10	34 (3.5, 25)	
Rearview mirror lock nut	2	10	34 (3.5, 25)	Left hand threads.
CBS master cylinder stay bolt	2	6	12 (1.2, 9)	
Knocker pivot screw	1	6	2.5 (0.26, 1.8)	Left hand threads.
Knocker pivot nut	1	6	10 (1.0, 7)	Left hand threads, U-nut
CBS master cylinder mounting bolt	2	6	12 (1.2, 9)	
CBS master cylinder cover bolt	1	6	12 (1.2, 9)	
Brake caliper mounting bolt	2	8	30 (3.1, 22)	ALOC bolt: replace with new ones.
Brake caliper torque pin	1	8	22 (2.2, 16)	
Brake caliper pin	1	8	18 (1.8, 13)	

### LIGHTS/METERS/SWITCHES

ITEM	Q'TY	THREAD DIA. (mm)	TORQUE N·m (kgf·m, lbf·ft)	REMARKS
Front/rear turn signal light lens screw ('13 model)	4	4	0.9 (0.09, 0.7)	
Rear turn signal light lens screw ('13 model)	2	6	8.8 (0.9, 6.5)	U-nut
License light lens screw ('13 model)	2	4	1 (0.1, 0.7)	
License light unit mounting nut ('13 model)	2	5	4.3 (0.44, 3.2)	U-nut
License light unit mounting screw (After '13 model)	2	4	1.2 (0.12, 0.9)	
Combination meter mounting screw (After '13 model)	4	5	1.2 (0.12, 0.9)	
Combination meter screw (After '13 model)	7	4	1.2 (0.12, 0.9)	
Speedometer mounting screw ('13 model)	4	5	1.1 (0.11, 0.8)	
Speedometer screw ('13 model)	8	3	0.54 (0.06, 0.4)	
VS sensor protector socket bolt	2	6	10 (1.0, 7)	Apply locking agent to the threads.
Fuel lid/seat opener lower cover screw	1	4	1.1 (0.11, 0.8)	
Key shutter socket bolt	1	5	5.1 (0.52, 3.8)	
Ignition switch mounting screw	2	6	9 (0.9, 6.6)	

## GENERAL INFORMATION

### OTHERS

ITEM	Q'TY	THREAD DIA. (mm)	TORQUE N·m (kgf·m, lbf·ft)	REMARKS
Sidestand pivot nut	1	10	29 (3.0, 21)	
Sidestand pivot bolt	1	10	10 (1.0, 7)	
Rear reflex reflector mounting nut	2	6	1.5 (0.15, 1.1)	U-nut
Tail reflex reflector mounting nut	1	5	1.5 (0.15, 1.1)	U-nut
Brake lock knob stopper nut	1	14	2.6 (0.27, 1.9)	

# LUBRICATION & SEAL POINTS

## ENGINE

MATERIAL	LOCATION	REMARKS
Liquid sealant (Three Bond 1207B or 1215 or LOCTITE 5060S or 5020 or equivalent)	Right crankcase mating surface	See page 15-10
	Cylinder head-to-water pump holder mating surface	See page 10-21
Liquid sealant (Three Bond 5211C or 1215 or SHIN-ETSU-SILICONE KE45T or LOCTITE 5060S or 5020 or equivalent)	Cylinder head-to-rubber seal mating surface	See page 10-7
	Cylinder head-to-water pump joint mating surface	See page 9-11
Molybdenum oil solution (a mixture of 1/2 engine oil and 1/2 molybdenum disulfide grease)	Camshaft cam lobes	
	Decompressor cam area and rotating surface	
	Rocker arm needle bearing sliding surface	
	Rocker arm shaft sliding surface	
Molybdenum disulfide paste (SUMICO MOLYPASTE 300 or equivalent)	Valve stem sliding surface and stem end	
	Water pump shaft mating area with camshaft	
Grease (Shell ALVANIA R3 or IDEMITSU AUTOREX B or NIPPON OIL POWERNOC WB3 or equivalent)	Driven face boss inner surface	7.3 – 8.3 g
	Movable driven face guide groove	1.7 – 2.2 g
Grease (NIPPON OIL P/U N6B or N6C or equivalent)	Driven face ball bearing sliding area	
Grease (Shell RETINEX LX2 or NIPPON OIL P/U N6B or equivalent)	Driven face needle bearing sliding area	
Engine oil (Without molybdenum additives)	Oil pump drive and driven gear teeth	
	Oil pump inner and outer rotor whole surface	
	Oil pump shaft sliding surface	
	Fuel injector seal ring	
	Rocker arm roller surface	
	Cylinder head washer whole surface	
	Camshaft bearing	
	Cam sprocket teeth	
	Cam chain whole surface	
	Valve stem seal inner surface	
	Timing sprocket teeth	
	Cylinder inner surface	
	Piston sliding surface and ring grooves	
	Piston pin hole inner surface	
	Piston ring whole surface	
	Piston pin outer surface	
	Connecting rod small end inner surface	
	Connecting rod big end bearing	Fill up 3 cm <sup>3</sup> minimum
	Crankshaft bearings	Fill up 2 cm <sup>3</sup> minimum
	Crankshaft bearing plunger sliding surface	
	Bearing area of drive, counter and final gear shaft	
	Drive, counter and final gear teeth	
	Ball and needle bearing sliding area	
Each O-ring whole surface		
Each oil seal lips and outer surfaces		

# GENERAL INFORMATION

## FRAME

MATERIAL	LOCATION	REMARKS
Multi-purpose grease with extreme pressure (recommended: EXCELIGHT EP2 manufactured by KYODO YUSHI, japan. or Shell ALVANIA EP2 or equivalent)	Steering bearing race	Spread each 3 - 5 g
	Steering stem dust seal lip	Spread each 3 - 5 g
Multi-purpose grease	Front wheel dust seal lip	
	Swingarm dust seal lip	
	Front wheel axle sliding surface	
	Throttle cable end and rolling area	Apply 0.1 - 0.2 g
	Finalshaft groove	Apply 0.03 - 0.04 g
	Finalshaft/swingarm bearing sliding area	
	Rear brake cam and shaft	Spread each 0.2 - 0.3 g
	Rear brake cam sleeve cavity	
	Rear brake anchor pin shaft	Spread 0.2 - 0.3 g
	Rear brake dust seal lip	
	Rear brake lever pivot bolt sliding surface	
	Seat catch contact area	Apply 1.5 g minimum
	Seat hinge sliding area	Apply 0.3 g minimum
	Passenger step pivot pin sliding area	
Centerstand pivot area		
Sidestand pivot area		
Silicone grease	1st/2nd rear brake cable cap boot inside	
	Front brake lever-to-master piston contacting area	Spread 0.1 g minimum
	Master cylinder piston boot inside	
	Knocker-to-master piston contacting area	Spread each 0.1 g
	Equalizer sliding area	Spread each 0.1 g
	Knocker pivot bolt sliding area	
	Front brake lever pivot sliding area	Spread each 0.1 g
	Brake caliper pin boot/pin sliding area	Spread 0.4 g minimum
	Brake caliper pad pin O-ring whole surface	
Brake caliper dust seal whole surface		
Brake fluid (DOT 3 or DOT 4)	Master cylinder inside and sliding area	
	Reservoir hose joint O-ring whole surface	
	Brake caliper piston seal whole surface	
	Brake caliper piston whole surface	
	Master cylinder piston cup	
Pro Honda Suspension Fluid SS-8 (10W) or equivalent	Fork dust seal and oil seal lips	
	Fork spring seat O-ring whole surface	
Honda bond A or Honda Handgrip Cement (U.S.A. only)	Handlebar grip rubber inside	
	Air cleaner connecting hose-to-housing mating area	

CABLE & HARNESS ROUTING ('13 MODEL)

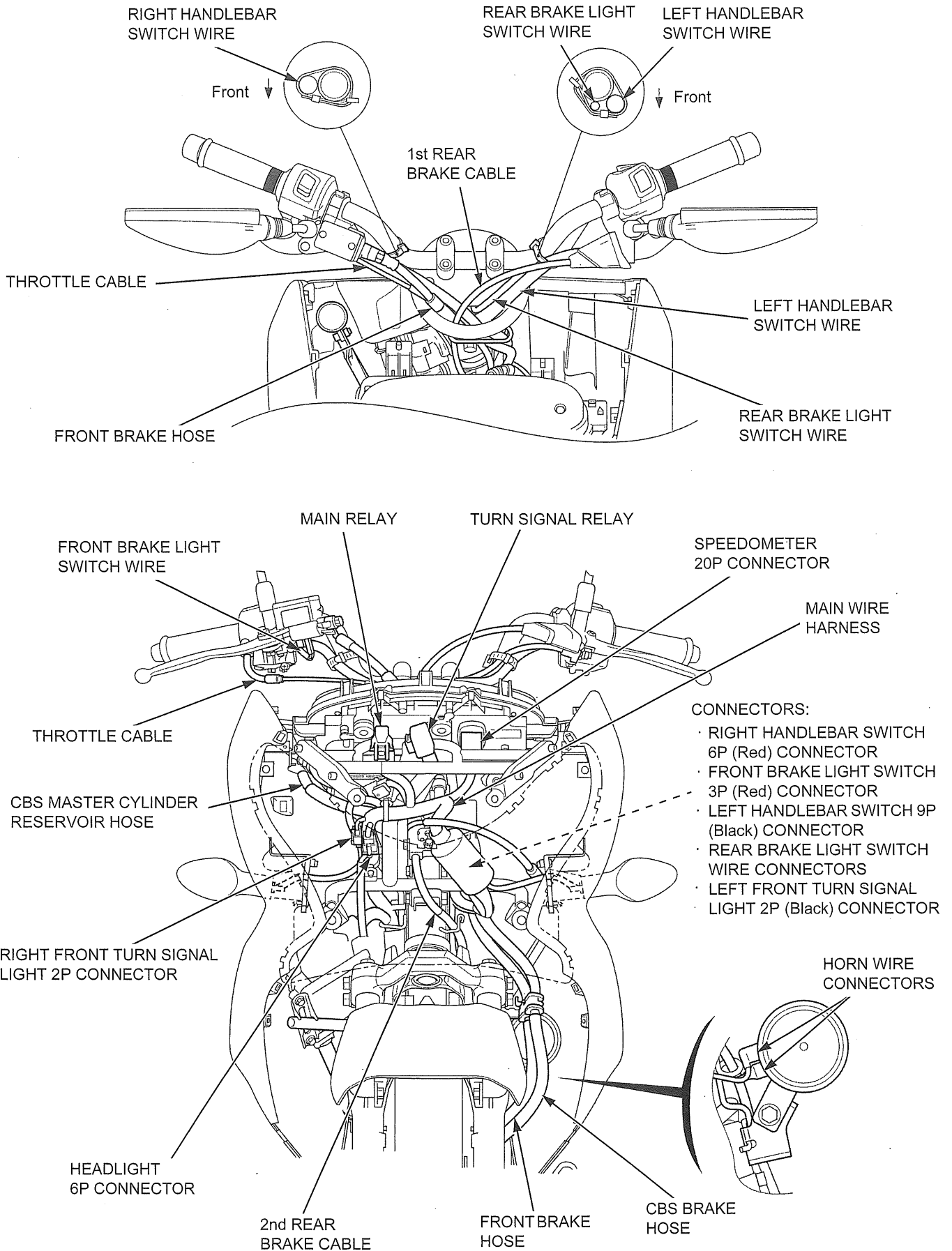

# GENERAL INFORMATION

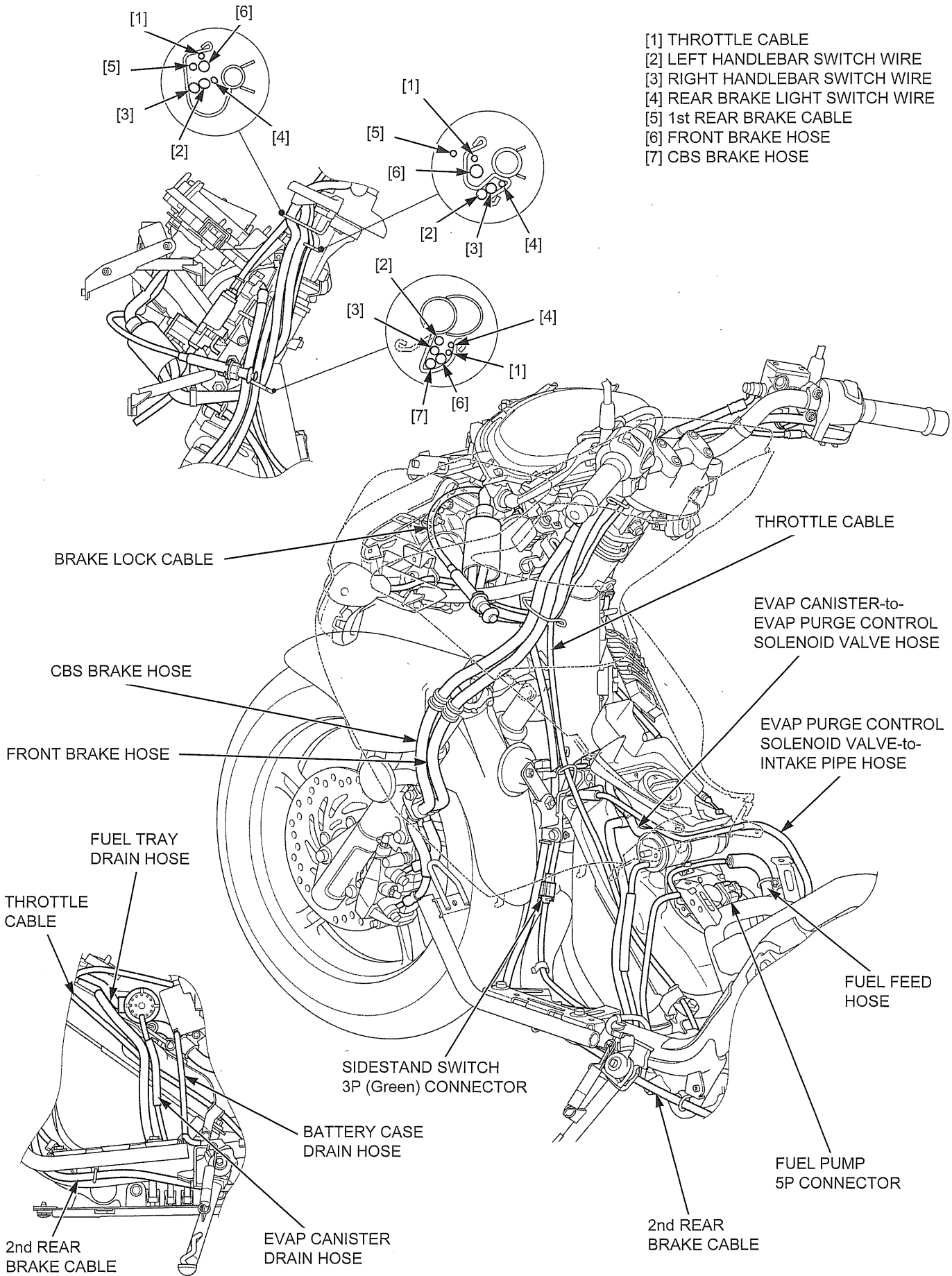



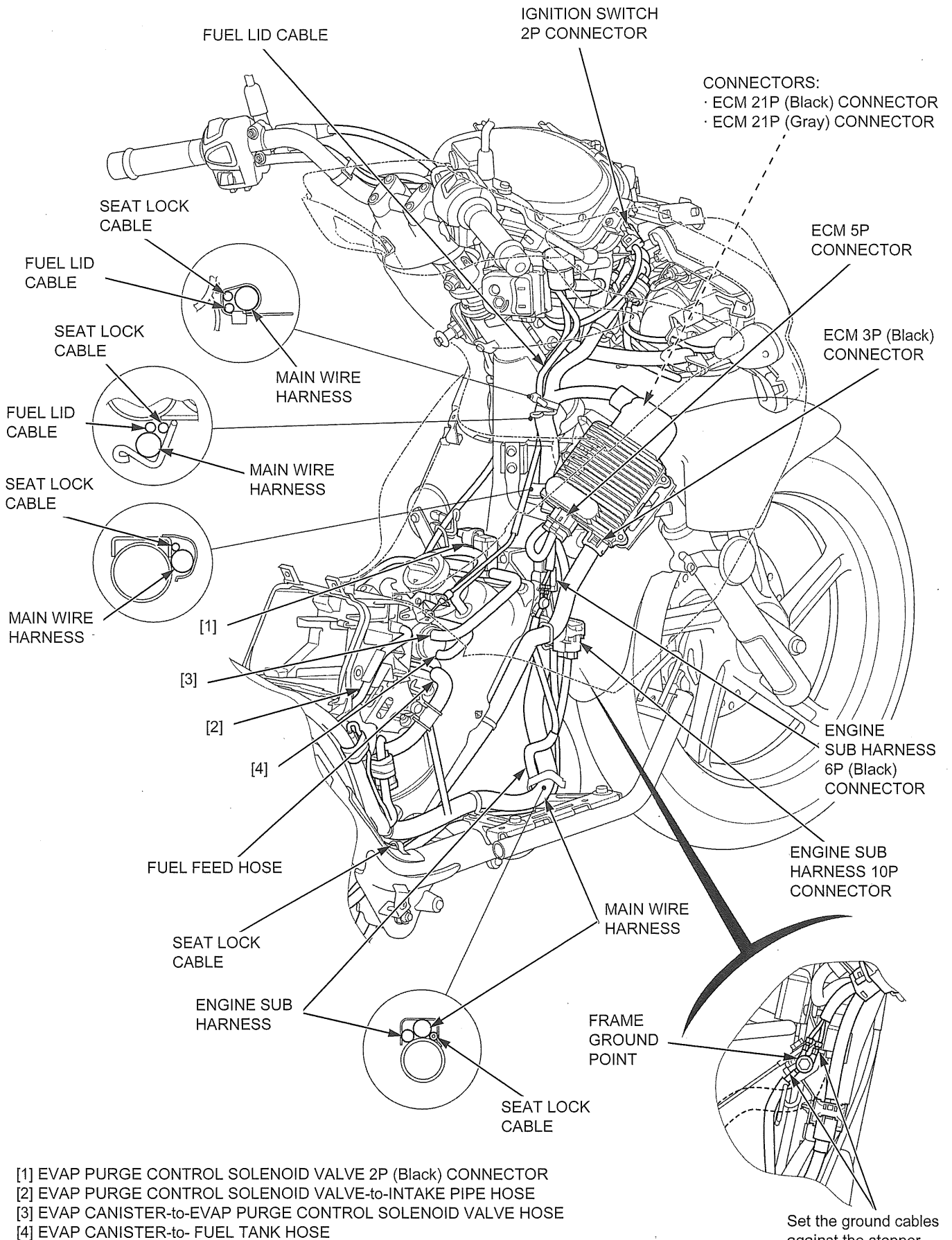

# GENERAL INFORMATION

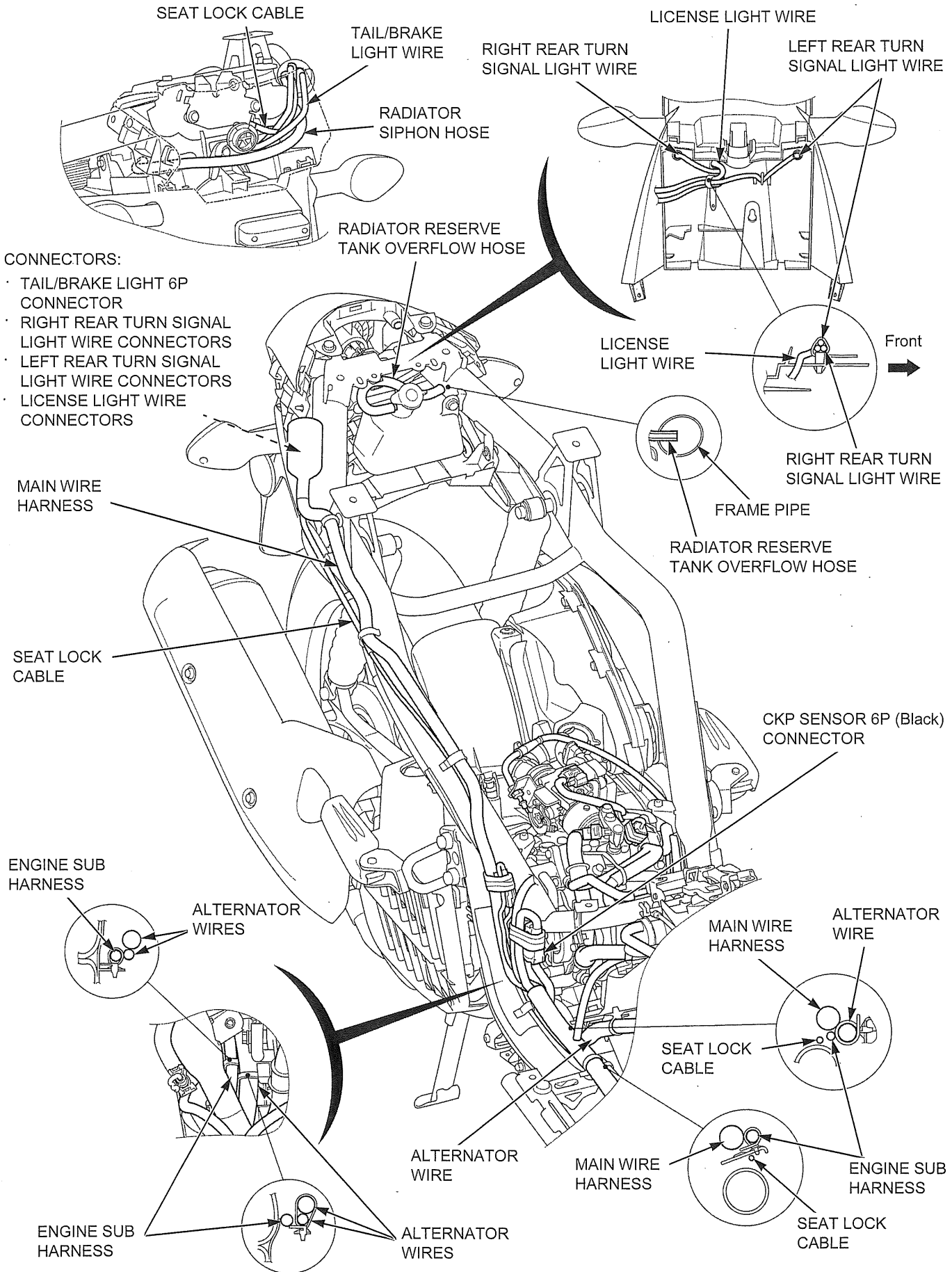

# GENERAL INFORMATION

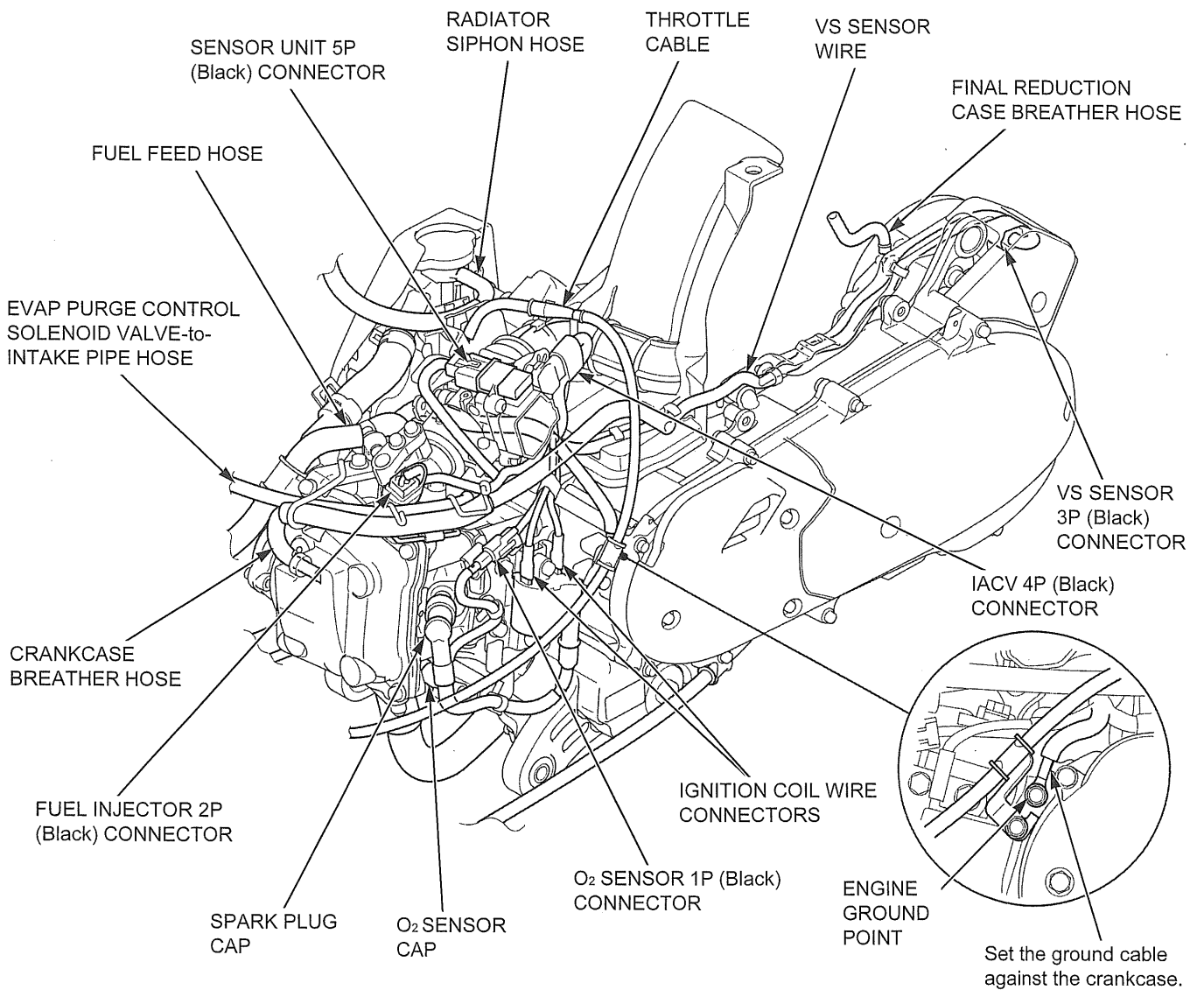
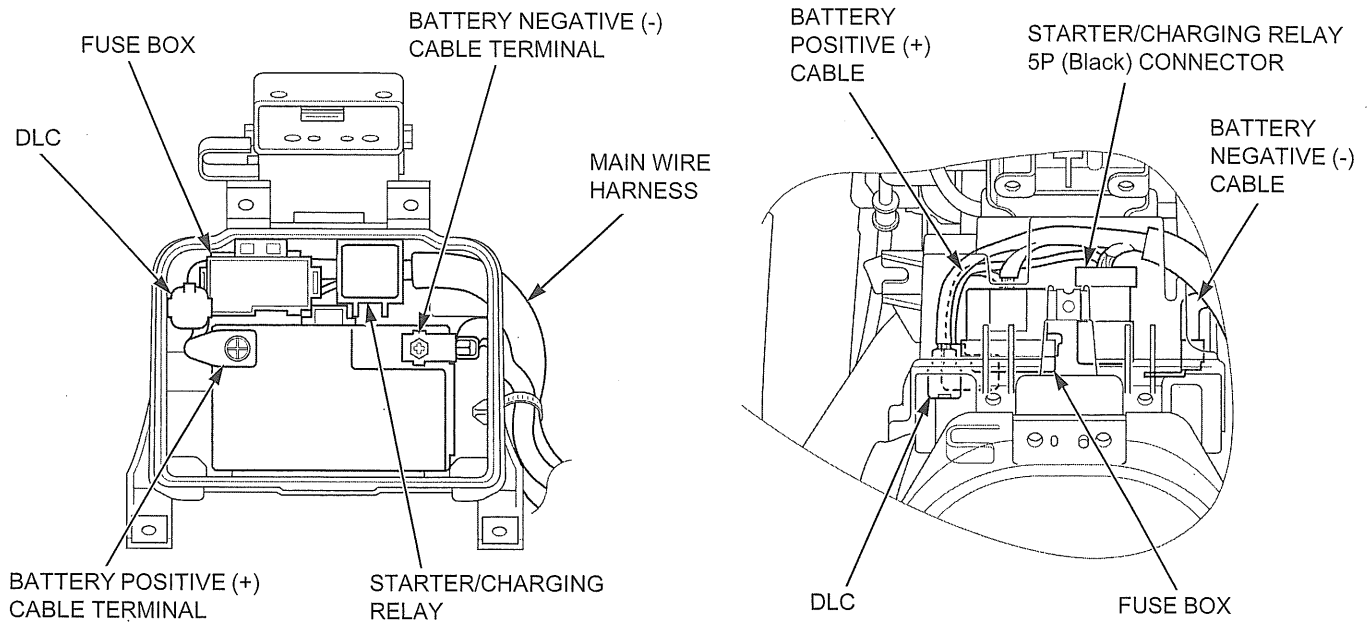

# GENERAL INFORMATION

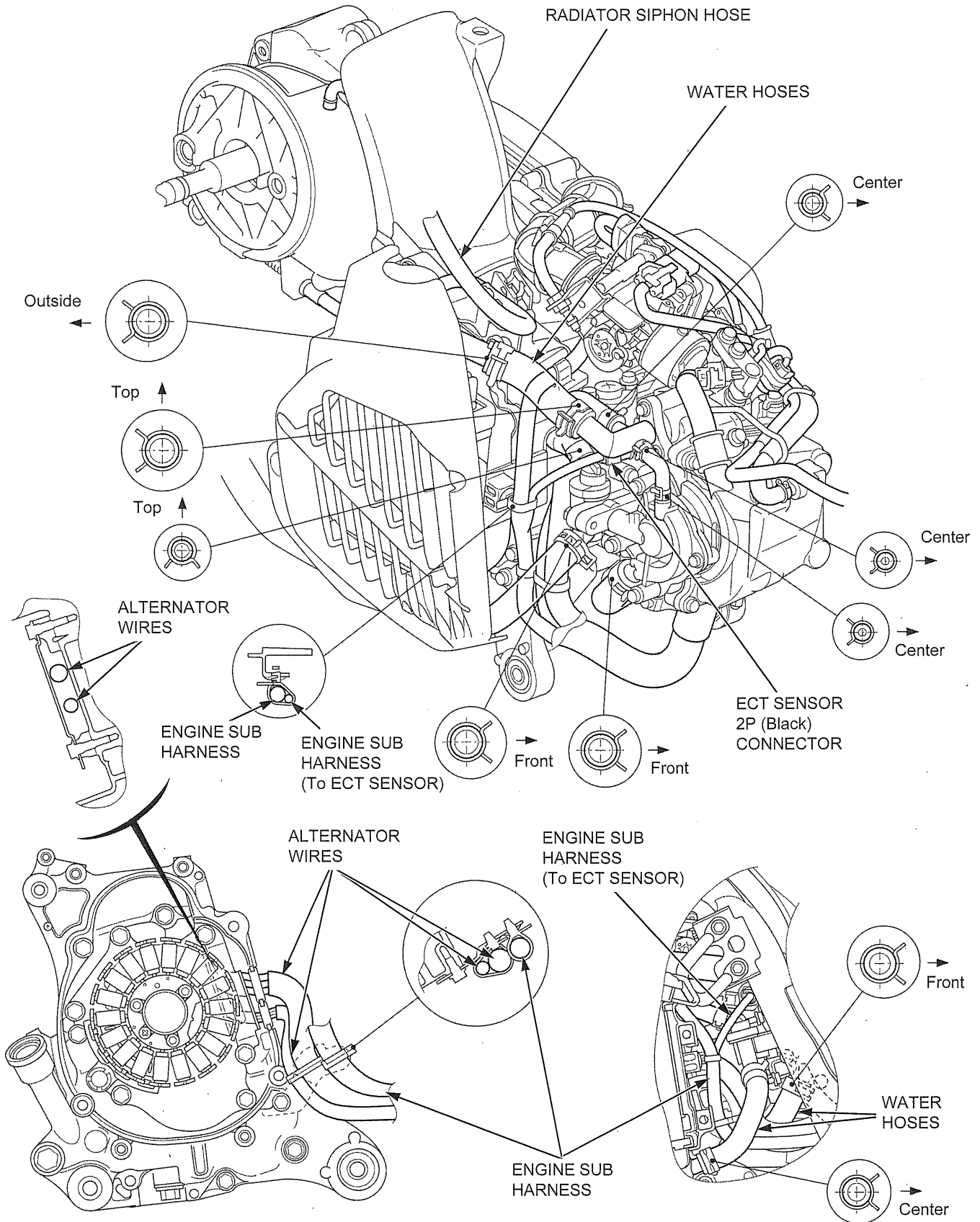

# CABLE & HARNESS ROUTING (AFTER '13 MODEL)

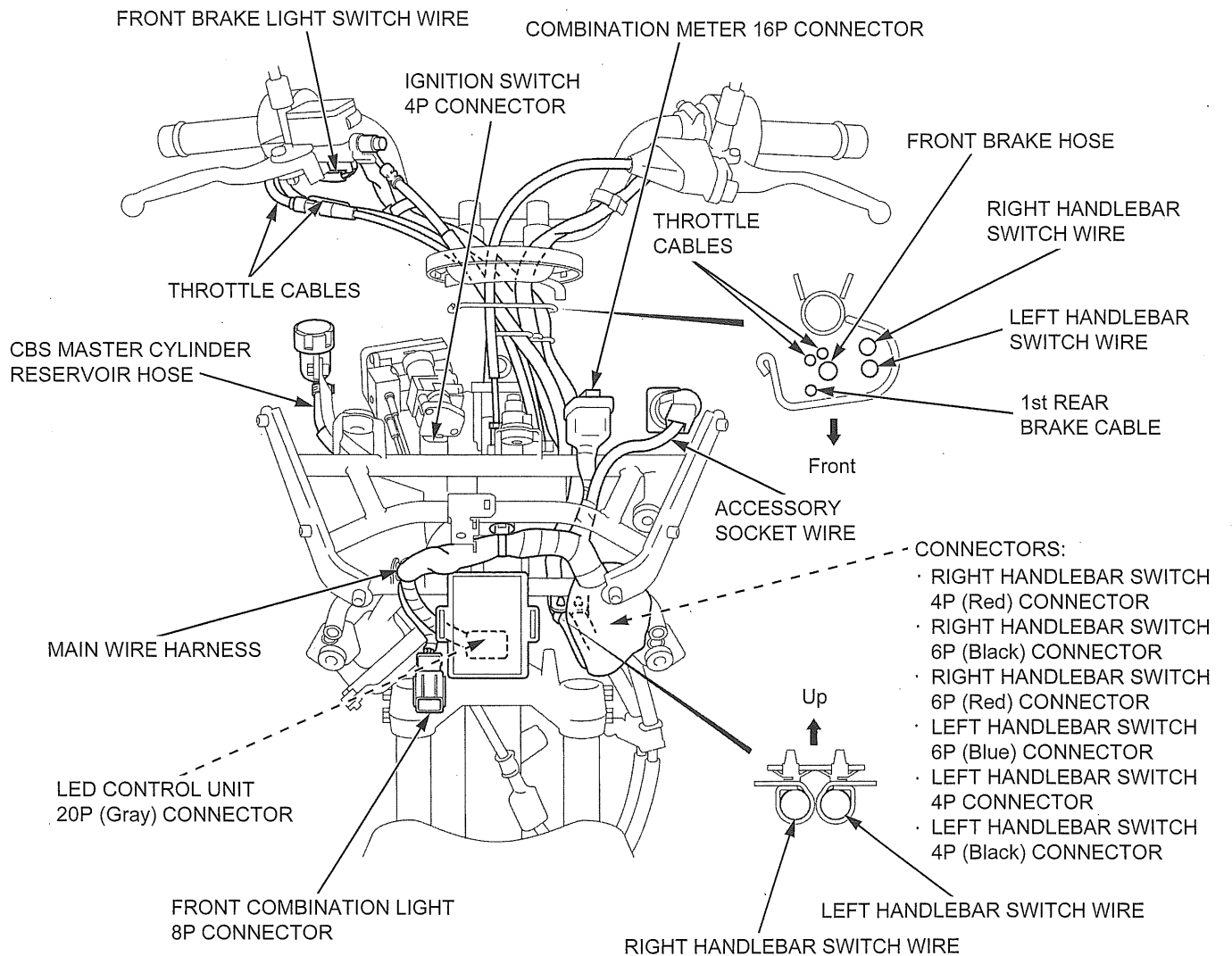
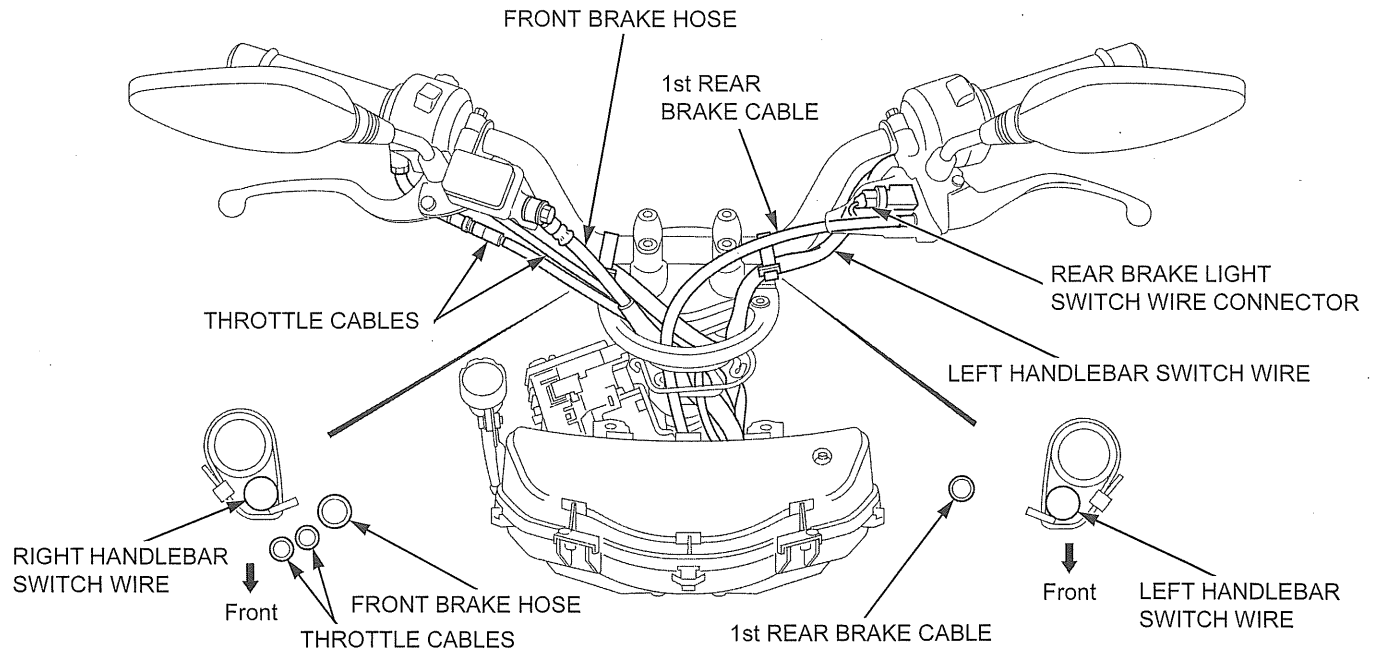

- CONNECTORS:
- RIGHT HANDLEBAR SWITCH 4P (Red) CONNECTOR
  - RIGHT HANDLEBAR SWITCH 6P (Black) CONNECTOR
  - RIGHT HANDLEBAR SWITCH 6P (Red) CONNECTOR
  - LEFT HANDLEBAR SWITCH 6P (Blue) CONNECTOR
  - LEFT HANDLEBAR SWITCH 4P CONNECTOR
  - LEFT HANDLEBAR SWITCH 4P (Black) CONNECTOR

# GENERAL INFORMATION

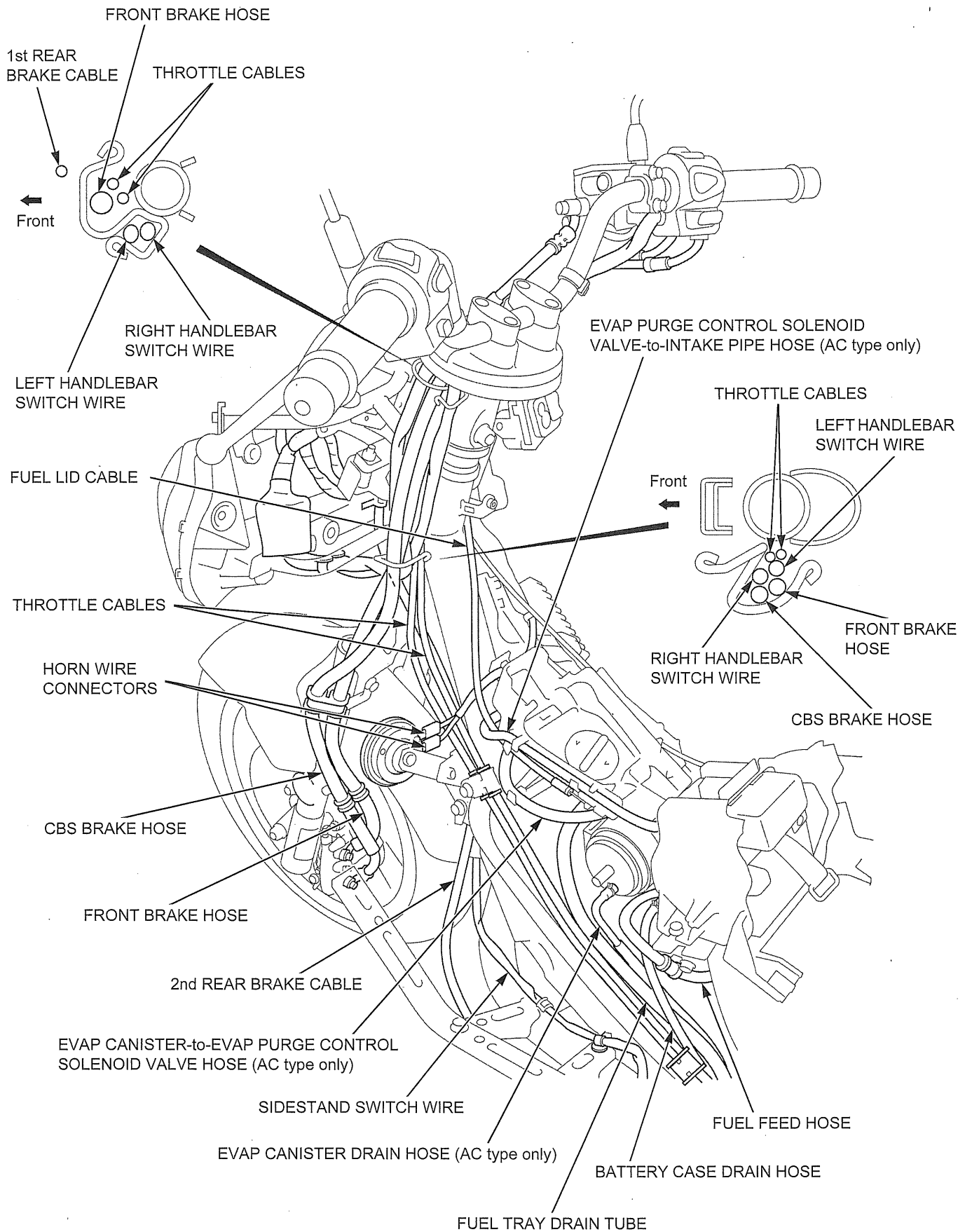

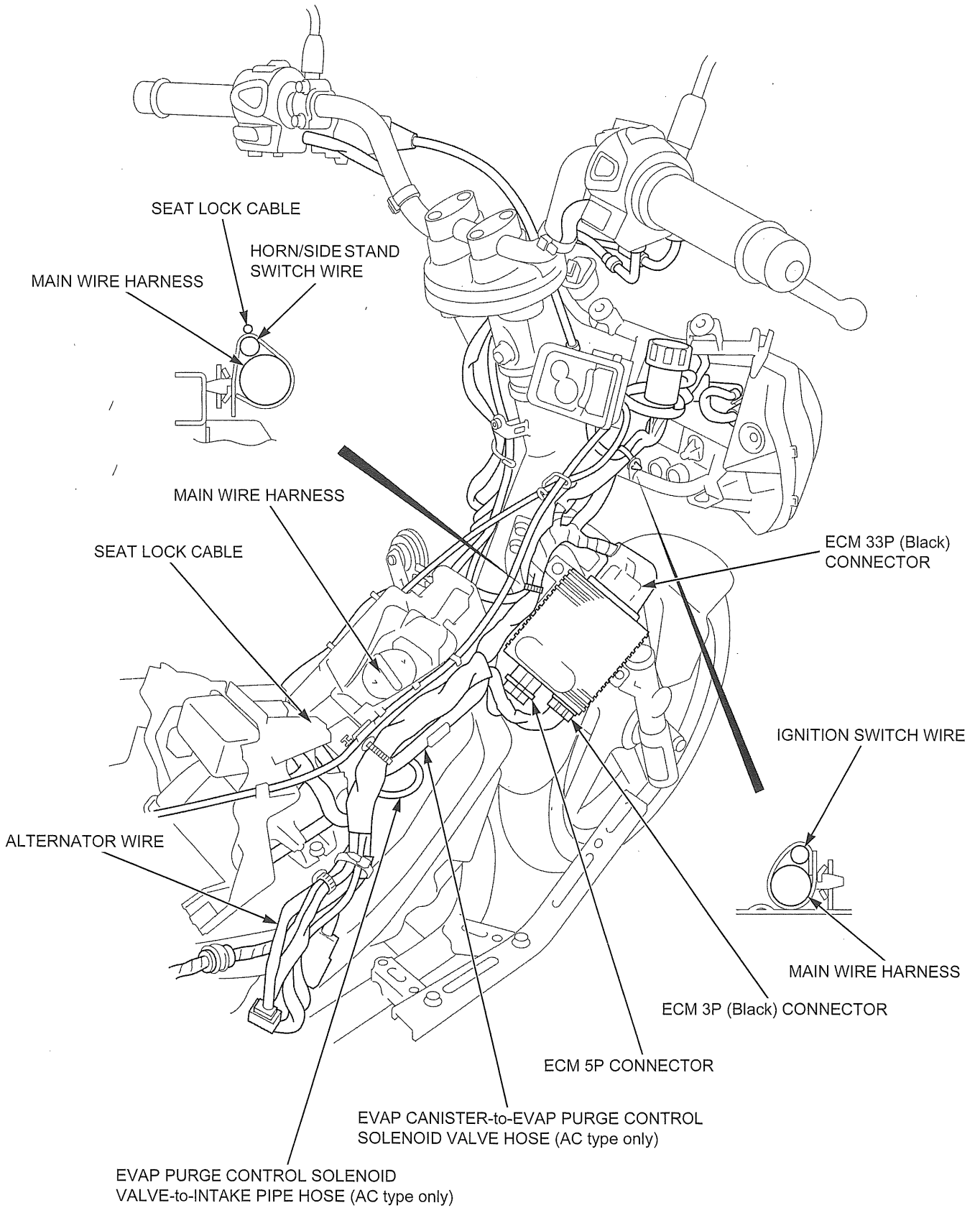

# GENERAL INFORMATION

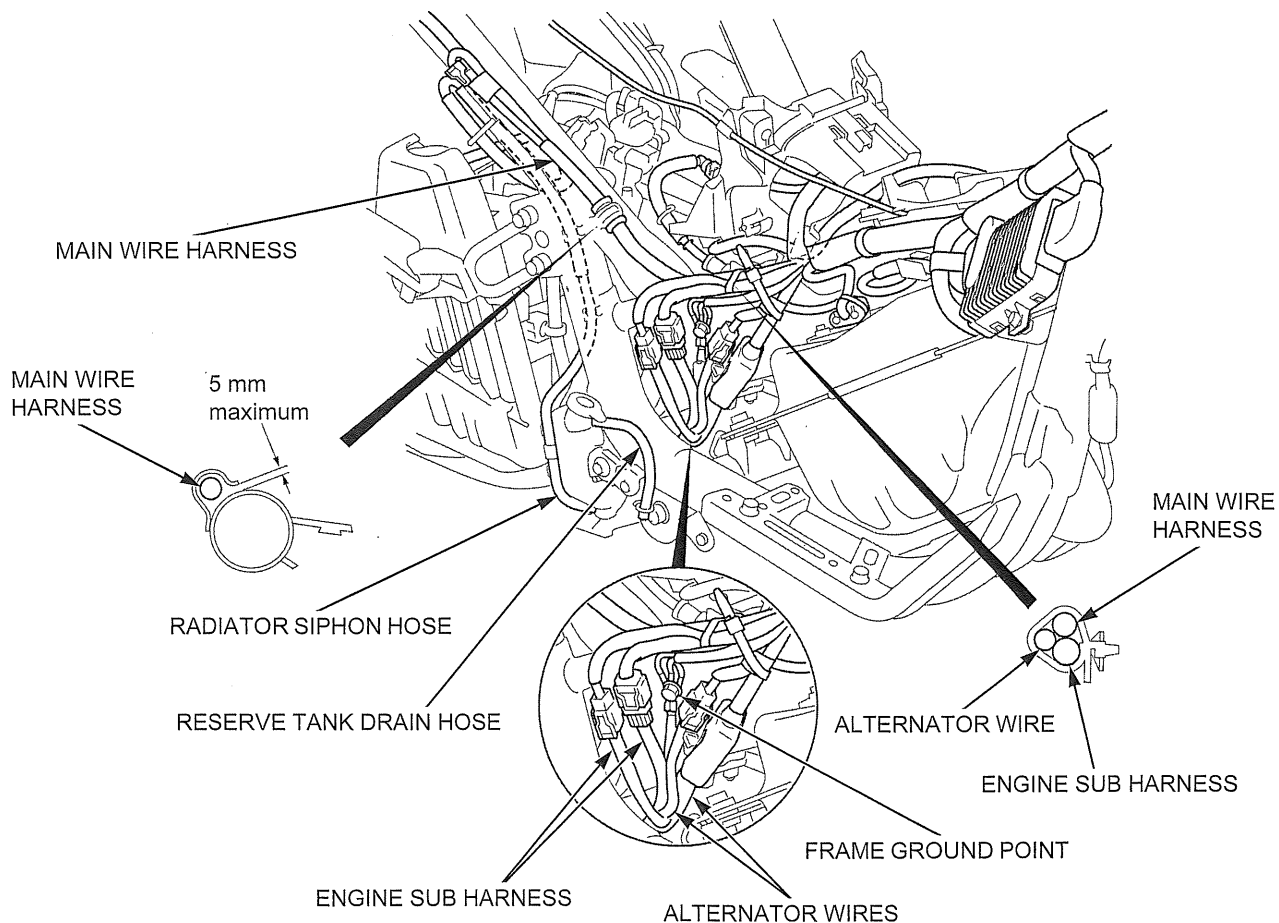
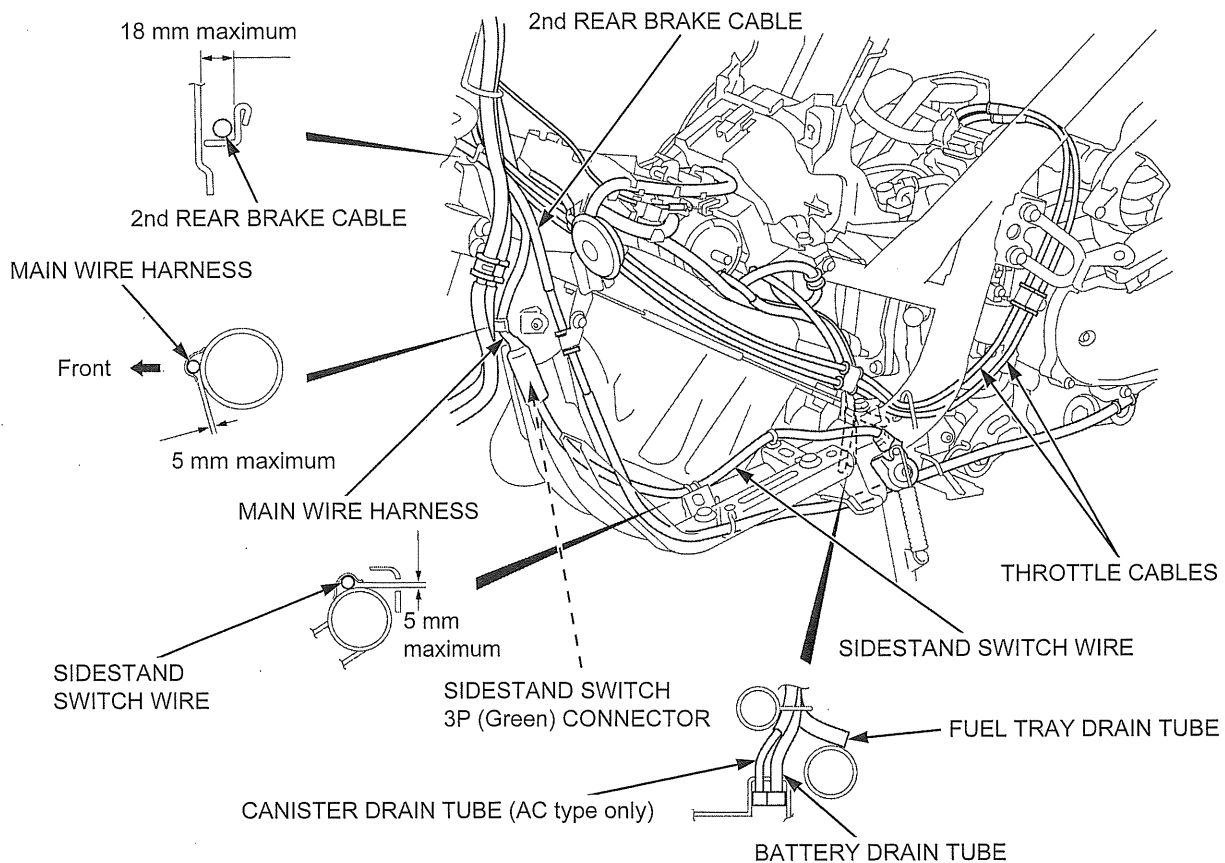



# GENERAL INFORMATION

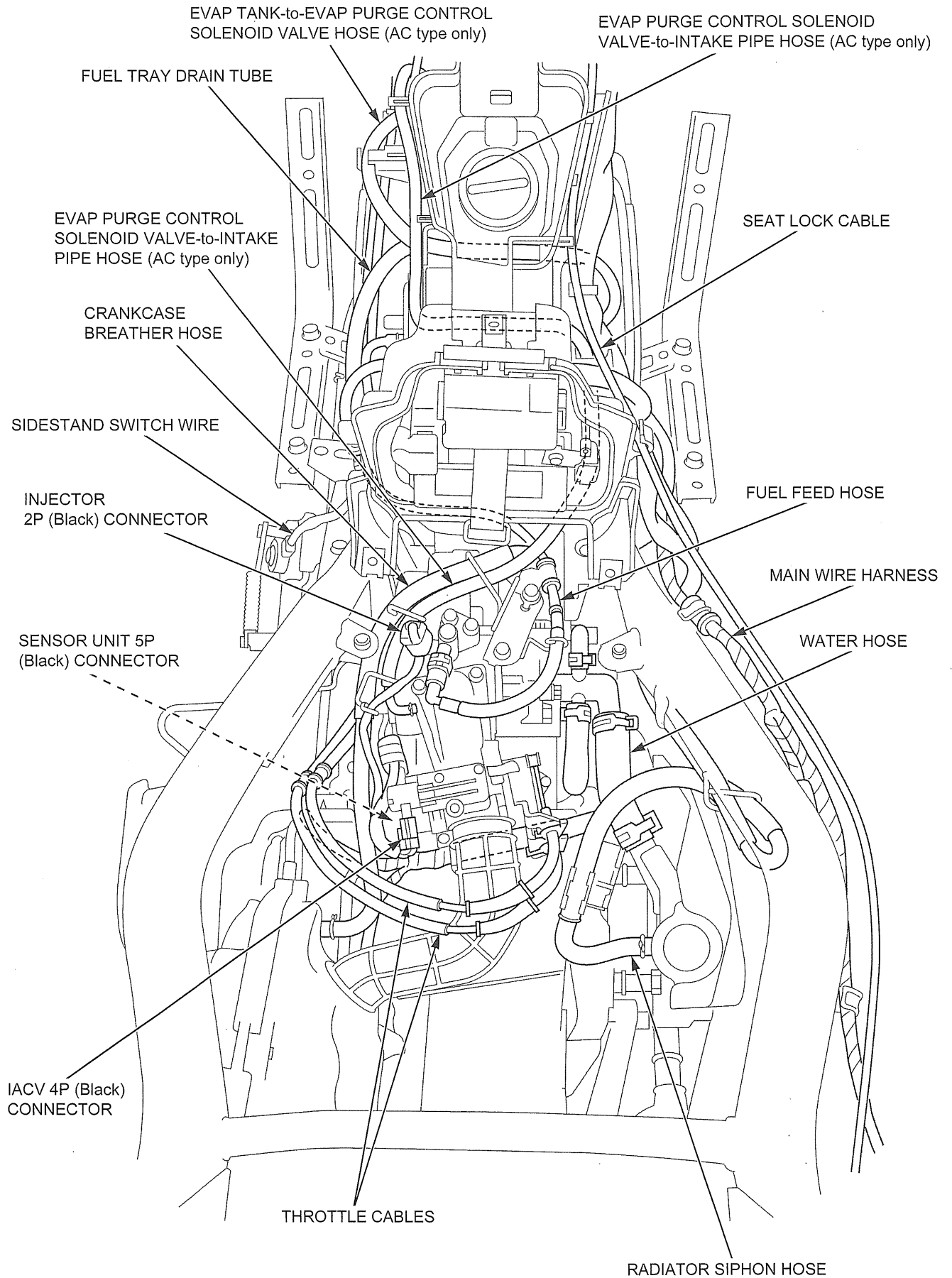

# GENERAL INFORMATION

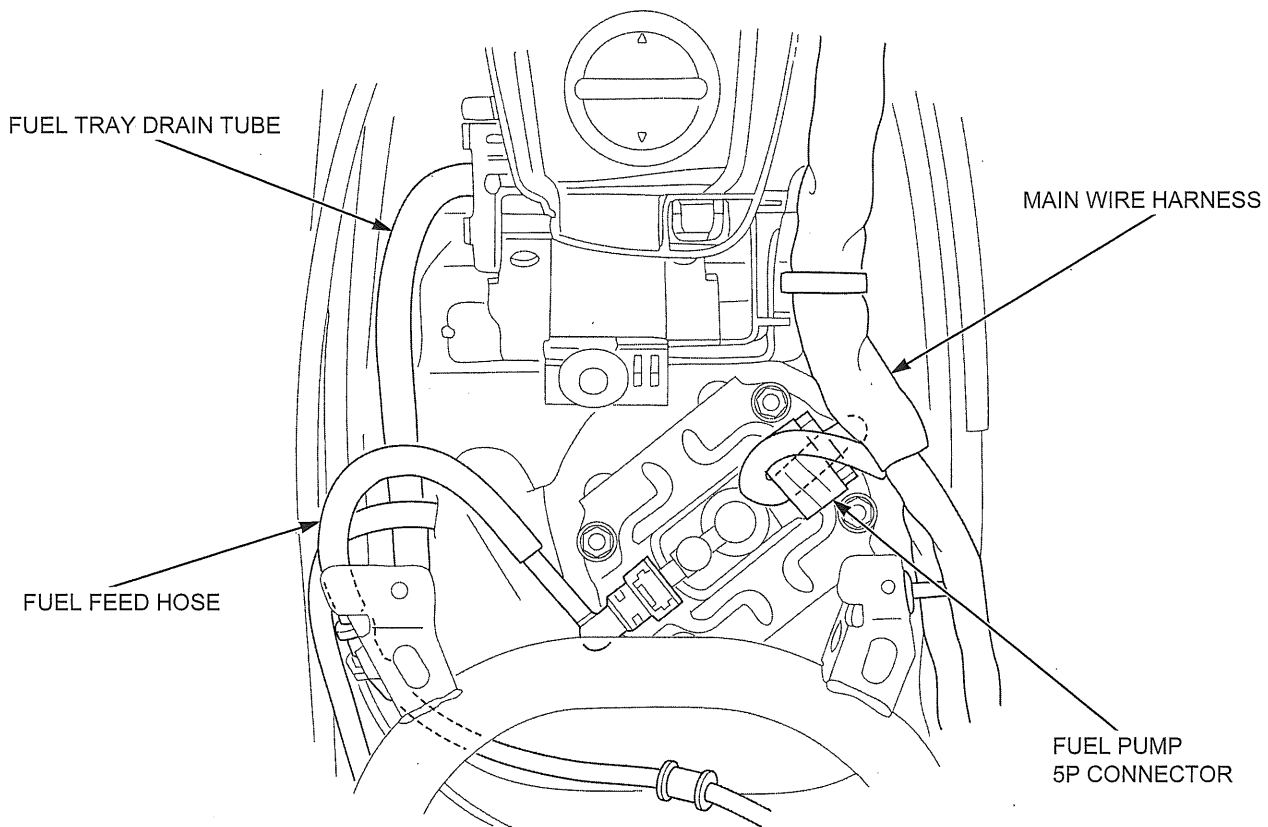
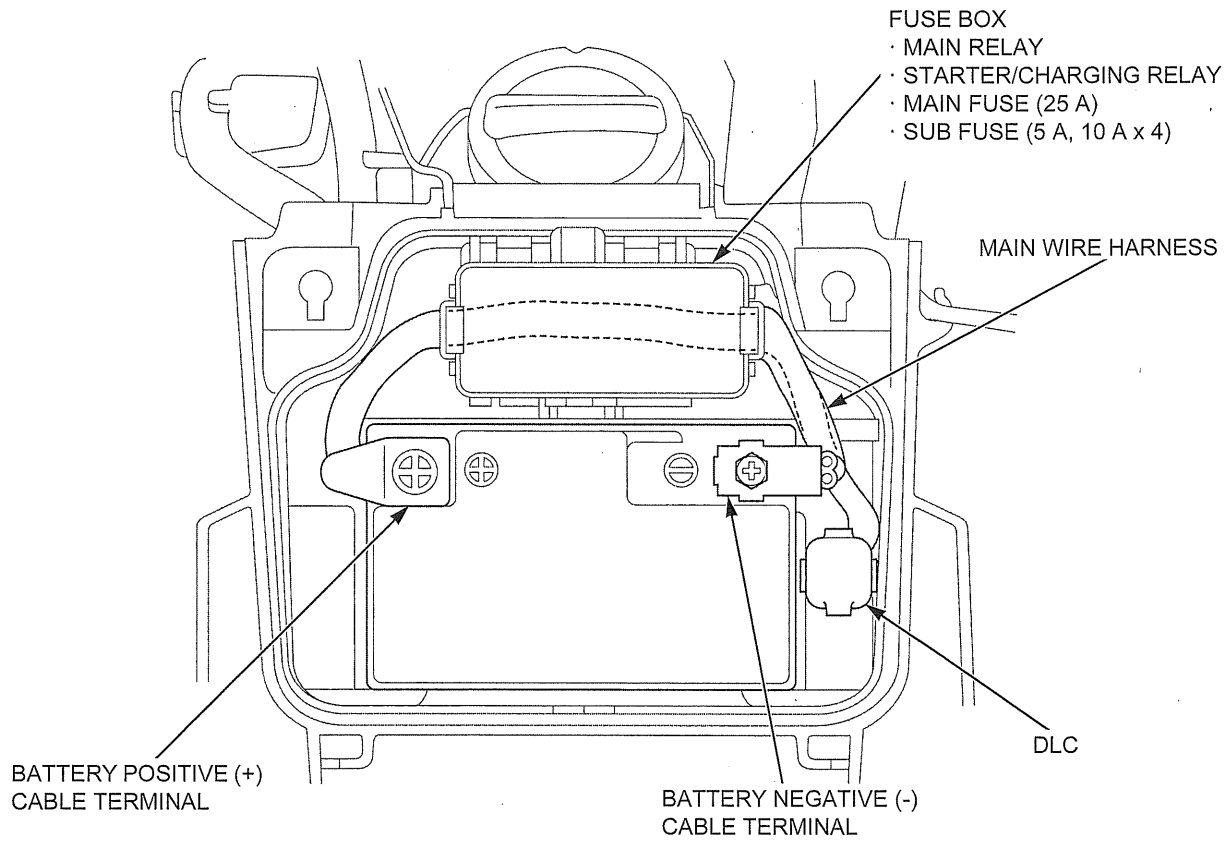

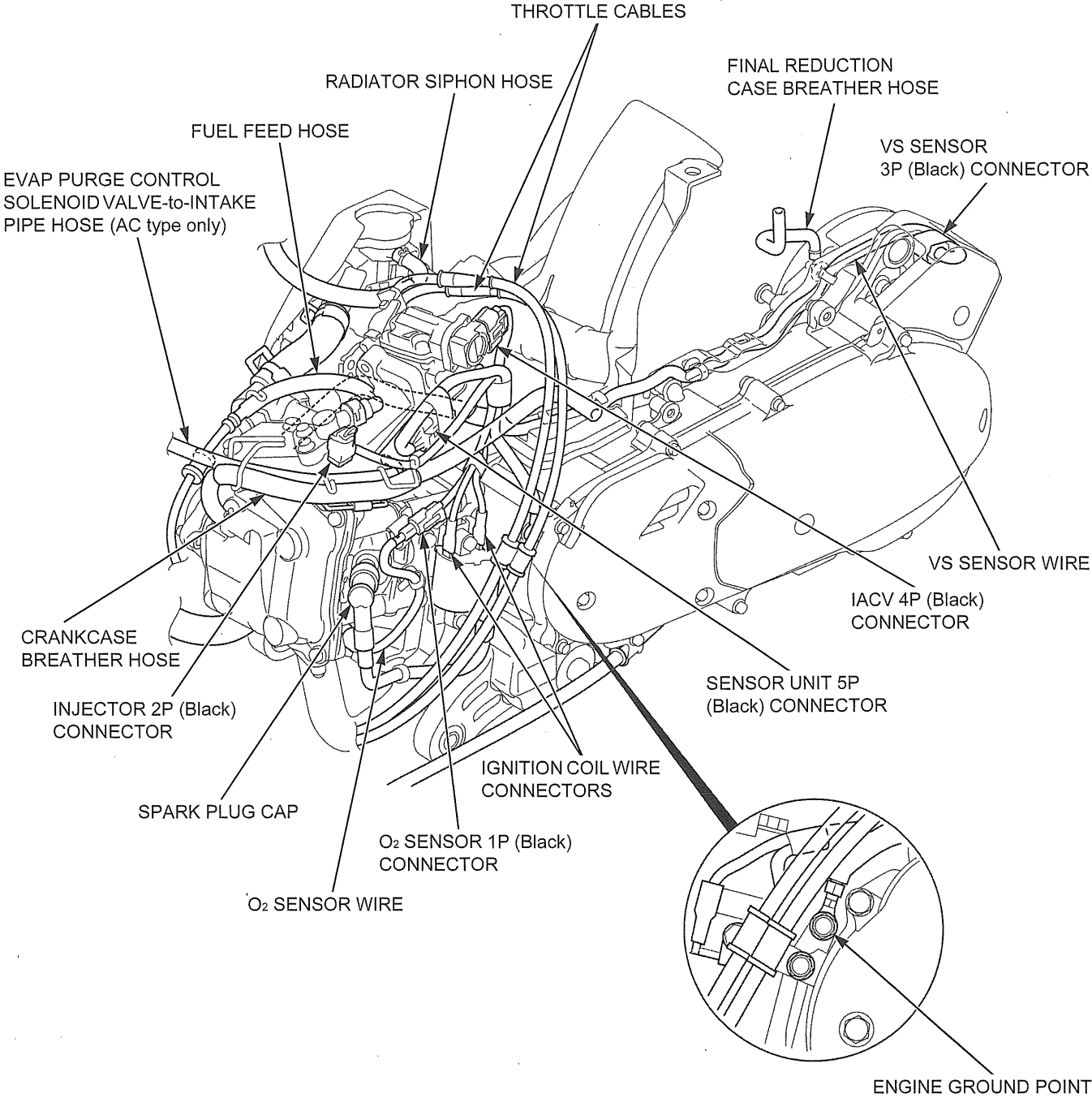

# GENERAL INFORMATION

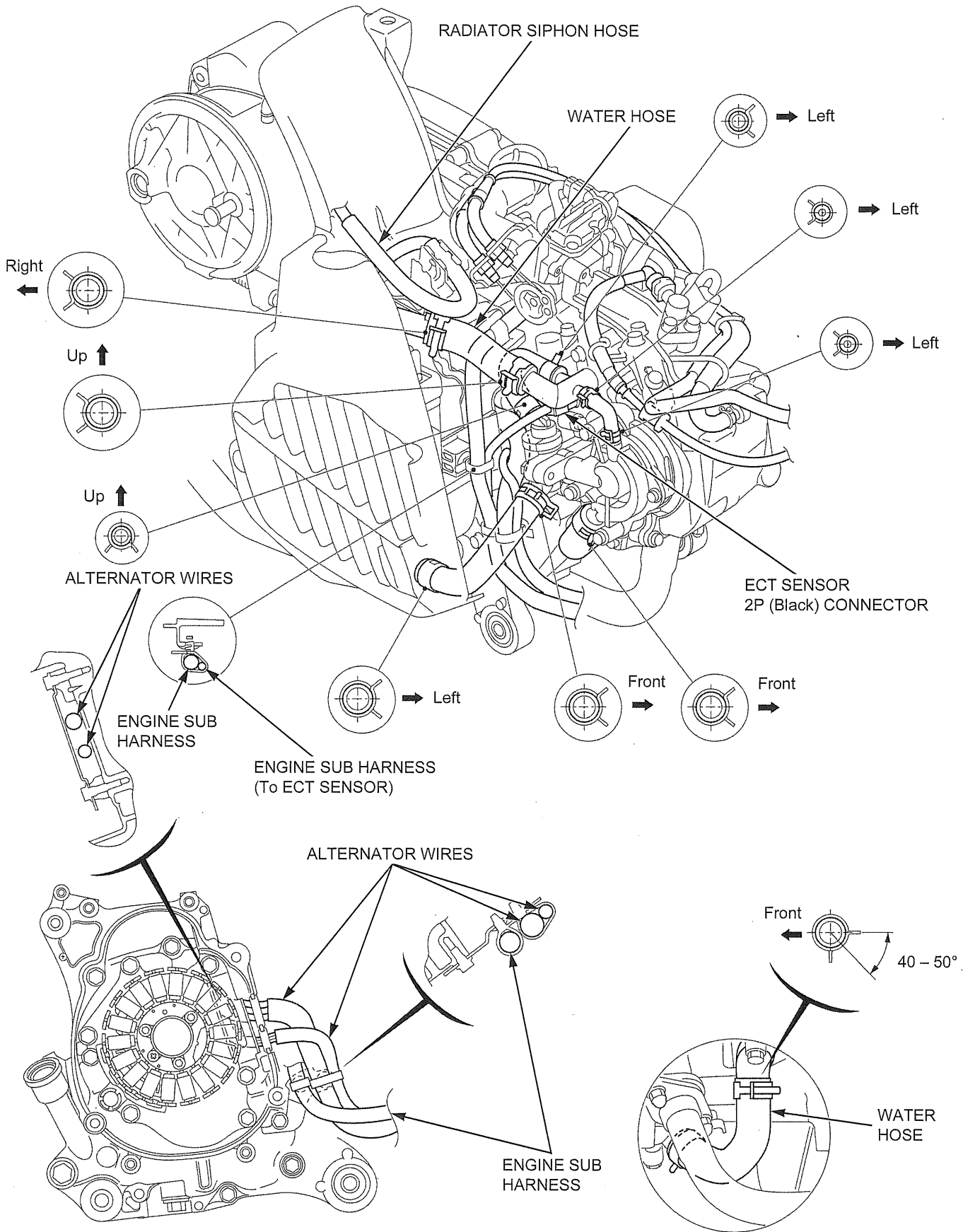

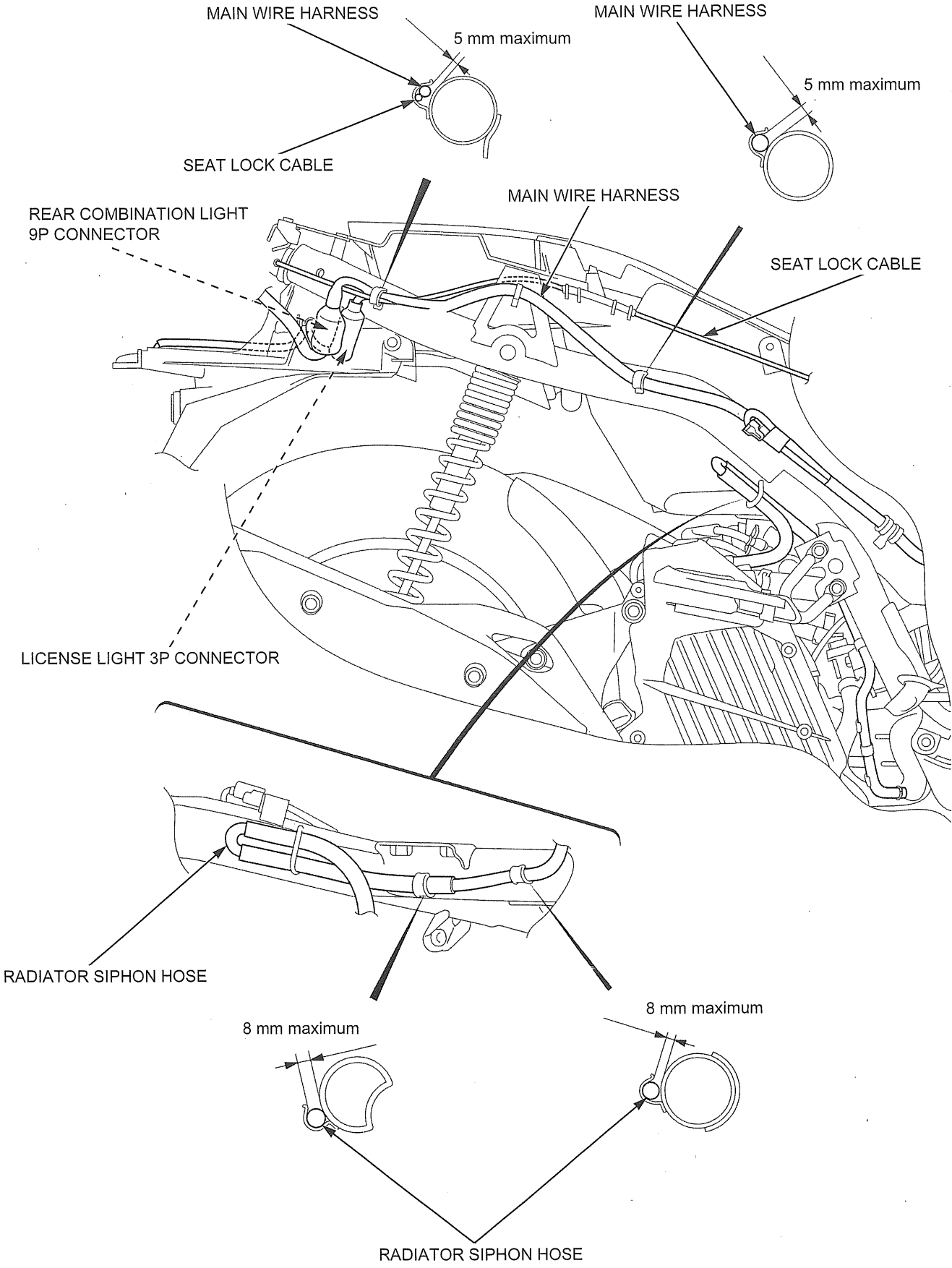

## GENERAL INFORMATION

# TECHNICAL FEATURE (AFTER '13 MODEL)

## FUEL PUMP SYSTEM WITH A FUEL FILTER BLOCKAGE REMINDER FUNCTION

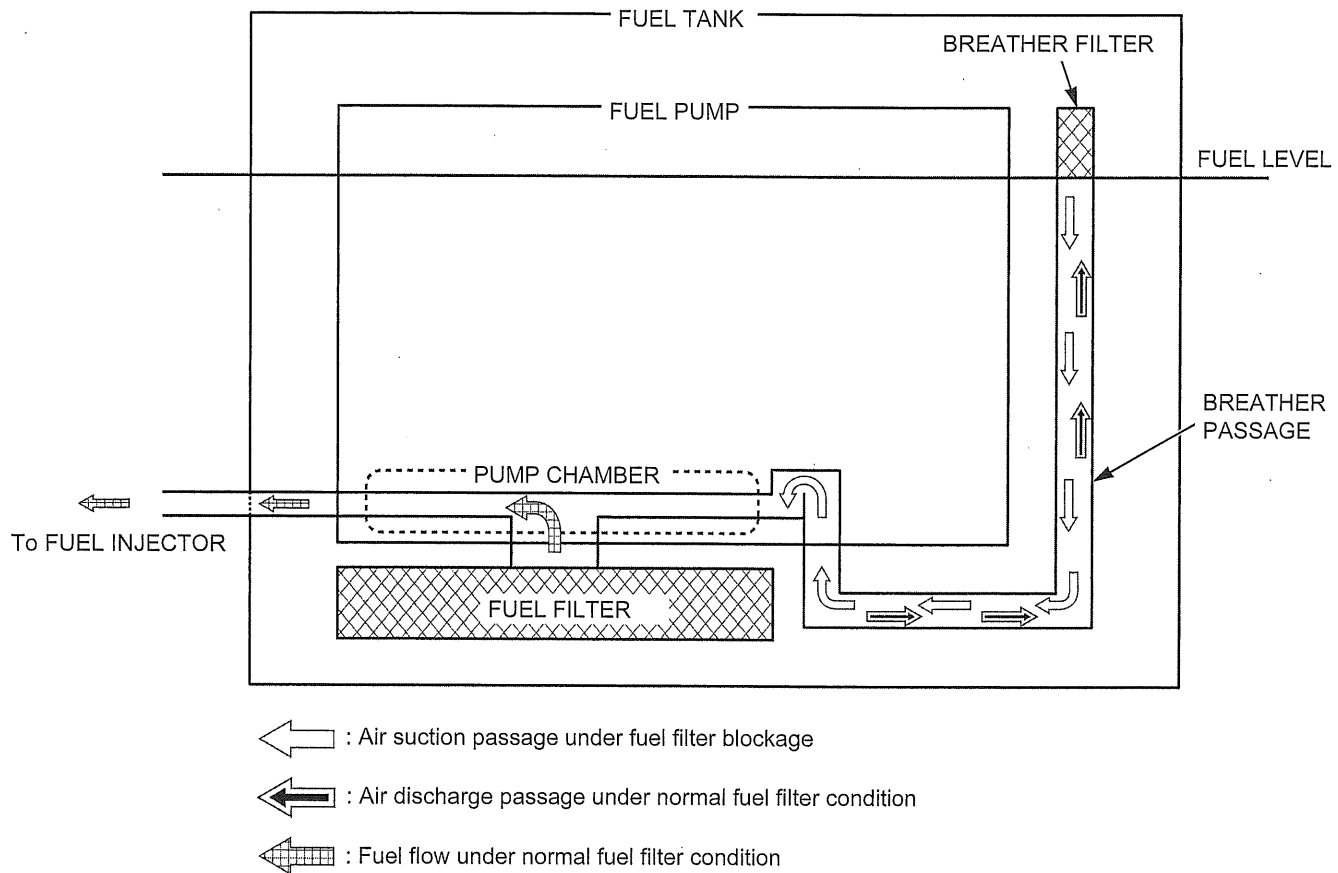

The fuel pump system of this model consists of the following components:

- Fuel pump chamber
- Fuel filter
- Breather passage
- Breather filter

Under normal conditions, the fuel pump chamber sucks fuel through the fuel filter and then supplies it to the injector.

When the fuel filter is clogged, the fuel is sucked into the pump chamber through the breather passage in order to keep the vehicle running. The breather filter is located in the upper inner side of fuel tank. When the fuel is consumed to the point where the breather filter is exposed above the fuel level, a certain amount of air will be drawn into the pump chamber via the breather filter and breather passage. This incoming air produces "a lack of fuel", which impairs engine performance in order to notify the rider of the fuel filter blockage. This symptom works as a reminder for the filter replacement.

This system eliminates the need of fuel filter replacement according to a fixed interval, as the rider will experience the symptom and notice the filter blockage during vehicle usage.

The driveability remains normal as long as the fuel level in tank is maintained above the breather filter because no air will be drawn into the pump chamber, even when the fuel filter is clogged.

If the fuel in tank is sufficient but such symptom as poor engine performance, lack of fuel, or engine start failure exist, perform the fuel supply test (page 7-9).

## EMISSION CONTROL SYSTEMS

### EXHAUST EMISSION REQUIREMENT

The U.S. Environmental Protection Agency (EPA), California Air Resources Board (CARB) and Environment Canada require manufacturers to certify that their motorcycles comply with applicable emissions standards during their useful life, when operated and maintained according to the instructions provided.

### NOISE EMISSION REQUIREMENT

The EPA also requires that motorcycles built after January 1, 1983 comply with applicable noise emission standards for one year or 3,730 miles (6,000 km) after the time of sale to the ultimate purchaser, when operated and maintained according to the instructions provided.

### WARRANTY COMPLIANCE

Compliance with the terms of the Distributor's Limited Warranty for Honda Motorcycle Emission Control Systems is necessary in order to keep the emissions system warranty in effect.

### SOURCE OF EMISSIONS

The combustion process produces carbon monoxide (CO), oxides of nitrogen (NO<sub>x</sub>) and hydrocarbons (HC). The control of hydrocarbons and oxides of nitrogen is very important because, under certain conditions, they react to form photochemical smog when subject to sunlight. Carbon monoxide does not react in the same way, but it is toxic. Uncontrolled fuel evaporation also release hydrocarbons to the atmosphere.

Honda Motor Co., Ltd. utilizes various system (page 1-36) to reduce carbon monoxide, oxides of nitrogen and hydrocarbons.

### CRANKCASE EMISSION CONTROL SYSTEM

The engine is equipped with a closed crankcase system to prevent discharging crankcase emissions into the atmosphere. Blow-by gas is returned to the combustion chamber through the crankcase breather hose [1], air cleaner [2] and throttle body [3].

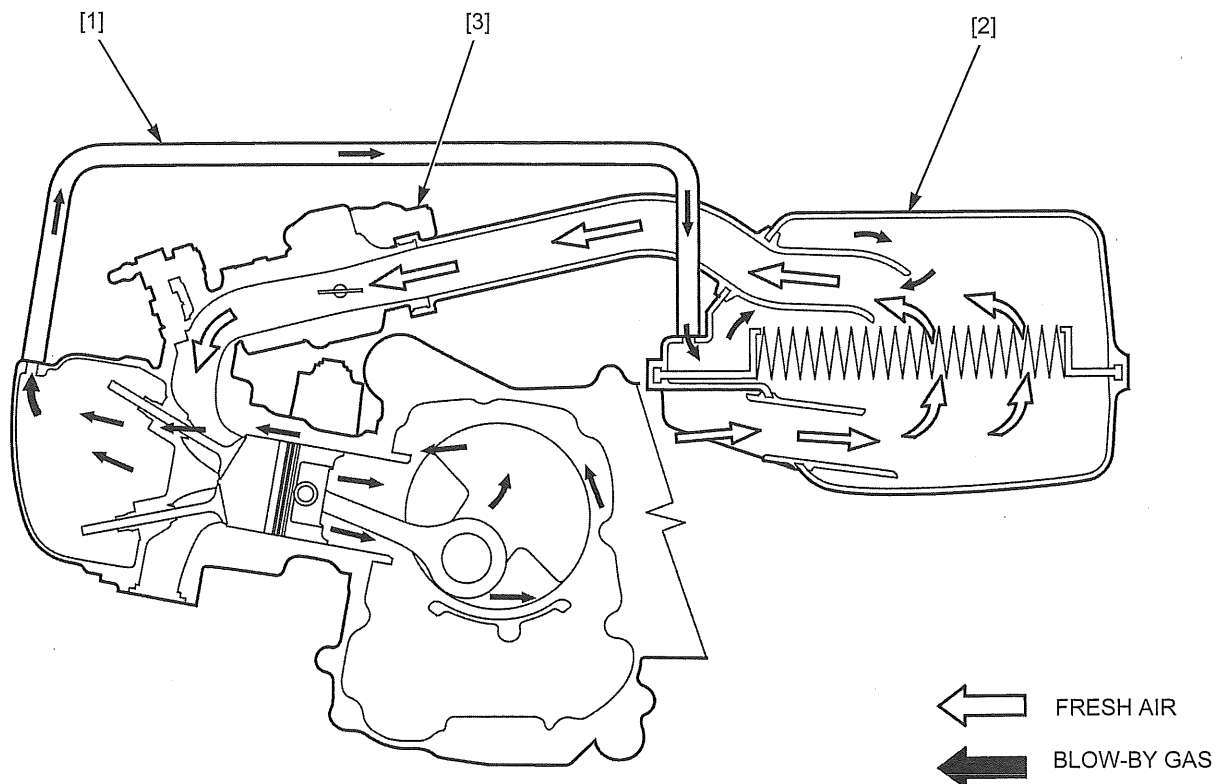

## GENERAL INFORMATION

### EXHAUST EMISSION CONTROL SYSTEM

The exhaust emission control system is composed of a three-way catalytic converter and PGM-FI system.

#### THREE-WAY CATALYTIC CONVERTER

This scooter is equipped with a three-way catalytic converter.

The three-way catalytic converter is in the exhaust system. Through chemical reactions, they converts HC, CO and NO<sub>x</sub> in the engine's exhaust to carbon dioxide (CO<sub>2</sub>), nitrogen (N<sub>2</sub>) and water vapor.

No adjustment to the system should be made, although periodic inspection of the components is recommended.

### EVAPORATIVE EMISSION CONTROL SYSTEM (EXCEPT AFTER '13 MODEL CM TYPE)

This model complies with CARB evaporative emission requirements. Fuel vapor from the fuel tank [1] is routed into the evaporative emission (EVAP) canister [2] where absorbed and stored while the engine is stopped. When the engine is running and the evaporative emission (EVAP) purge control solenoid valve [3] is open, fuel vapor in the EVAP canister is drawn into the engine through the intake pipe [4].

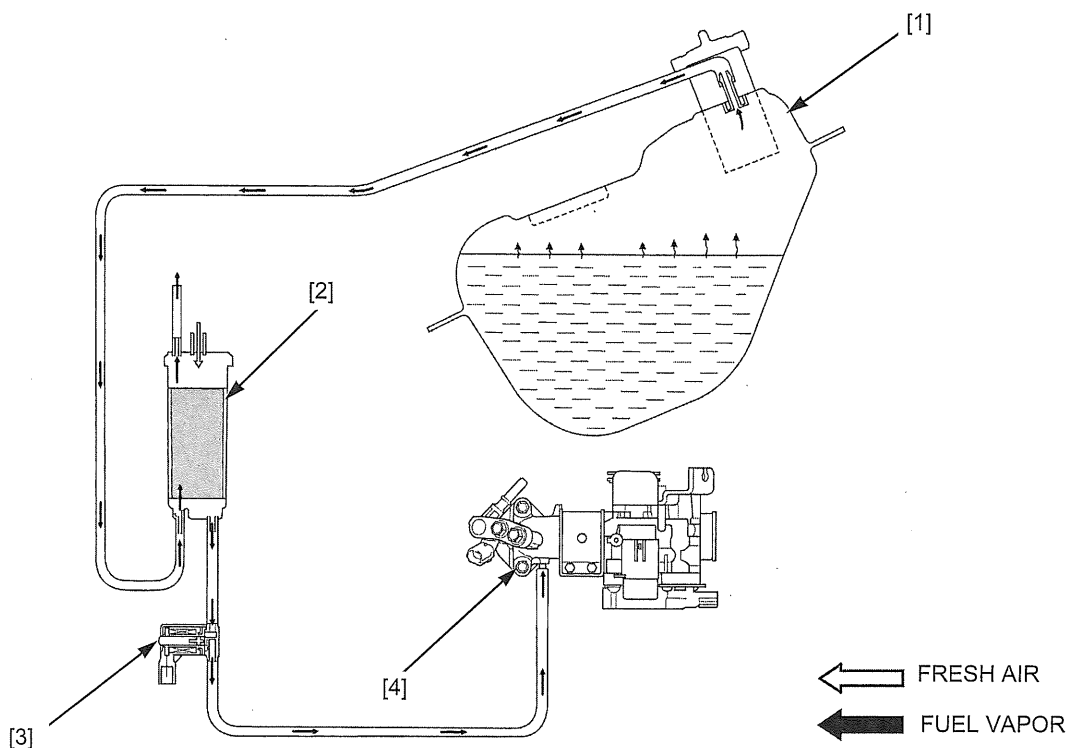

### FUEL PERMEATION EMISSION CONTROL SYSTEM

This scooter complies with the Fuel Permeation Emission Control regulations of the U.S. Environmental Protection Agency (EPA), California Air Resources Board (CARB), and Environment Canada (EC). The fuel tank, fuel hoses, and fuel vapor charge hoses used on this scooter incorporate fuel permeation control technologies. Tampering with the fuel tank, fuel hoses, or fuel vapor charge hoses to reduce or defeat the effectiveness of the fuel permeation technologies is prohibited by federal regulations.

### NOISE EMISSION CONTROL SYSTEM

**TAMPERING WITH THE NOISE CONTROL SYSTEM IS PROHIBITED:** U.S. Federal law prohibits, and Canadian provincial law may prohibit, the following acts or the causing thereof: (1) The removal or rendering inoperative by any person, other than for purposes of maintenance, repair or replacement, of any device or element of design incorporated into any vehicle for the purpose of noise control prior to its sale or delivery to the ultimate customer or while it is in use; or (2) the use of the vehicle after such device or element of design has been removed or rendered inoperative by any person.

AMONG THOSE ACTS PRESUMED TO CONSTITUTE TAMPERING ARE THE ACTS LISTED BELOW:

1. Removal of, or puncturing of the muffler, baffles, header pipes or any other component which conducts exhaust gases.
2. Removal of, or puncturing of any part of the intake system.
3. Lack of proper maintenance.
4. Removing or disabling any emissions compliance component, or replacing any compliance component with a non-complaint component.



## 2. FRAME/BODY PANELS/EXHAUST SYSTEM

---

SERVICE INFORMATION.....	2-3	LEFT INNER OUTER COVER (AFTER '13 MODEL) .....	2-13
TROUBLESHOOTING .....	2-3	RIGHT INNER OUTER COVER (AFTER '13 MODEL) .....	2-13
BODY PANEL LOCATIONS ('13 MODEL) ..	2-4	INNER COVER .....	2-14
BODY PANEL REMOVAL CHART ( '13 MODEL) .....	2-4	HANDLEBAR FRONT COVER .....	2-15
BODY PANEL LOCATIONS (AFTER '13 MODEL) .....	2-5	REAR METER PANEL .....	2-15
BODY PANEL REMOVAL CHART (AFTER '13 MODEL) .....	2-5	FRONT COVER .....	2-16
FRONT FENDER .....	2-6	FRONT LOWER COVER .....	2-18
FRONT GRILLE.....	2-6	PLUG MAINTENANCE LID.....	2-19
METER VISOR .....	2-7	FLOOR STEP.....	2-20
FRONT METER PANEL .....	2-8	GRAB RAIL COVER.....	2-21
FLOOR MAT .....	2-8	GRAB RAIL .....	2-22
SIDE COVER .....	2-9	BODY COVER.....	2-24
UNDER COVER.....	2-10	LUGGAGE BOX .....	2-26
SEAT.....	2-11	BATTERY BOX .....	2-27
CENTER COVER .....	2-11	REAR FENDER .....	2-28
METER PANEL COVER ('13 MODEL) .....	2-12	EXHAUST PIPE/MUFFLER.....	2-29
RIGHT INNER MAINTENANCE LID ( '13 MODEL) .....	2-12	CENTERSTAND .....	2-29

## FRAME/BODY PANELS/EXHAUST SYSTEM

### SERVICE INFORMATION

#### GENERAL

- This section covers removal and installation of the body panels and exhaust system.
- Always replace the exhaust pipe gasket after removing the exhaust pipe from the engine.
- When installing the exhaust system, loosely install all of the exhaust pipe fasteners. Always tighten the exhaust joint first, then tighten the mounting fasteners. If you tighten the mounting fasteners first, the exhaust pipe may not seat properly.
- Always start the engine and inspect the exhaust system for leaks after installation.

#### TORQUE VALUES

ITEM	Q'TY	THREAD DIA. (mm)	TORQUE N·m (kgf·m, lbf·ft)	REMARKS
Front reflex reflector mounting nut ('13 model)	2	6	1.5 (0.15, 1.1)	U-nut
Front turn signal light unit mounting nut ('13 model)	2	6	8.8 (0.9, 6.5)	U-nut
Tail/brake light unit mounting screw ('13 model)	4	4	1 (0.1, 0.7)	
Rear combination light unit mounting screw (After '13 model)	5	5	1.2 (0.12, 0.9)	
Luggage box nut (After '13 model)	2	6	3 (0.3, 2.2)	
Exhaust pipe joint nut	2	7	29 (3.0, 21)	For tightening sequence; See page 2-28
Muffler protector mounting bolt	2	6	10 (1.0, 7)	
Muffler mounting bolt	3	10	49 (5.0, 36)	For tightening sequence; See page 2-28
Exhaust pipe stud bolt	2	7	—	See page 2-28

### TROUBLESHOOTING

#### Excessive exhaust noise

- Broken exhaust system
- Exhaust gas leak

#### Poor performance

- Deformed exhaust system
- Exhaust gas leak
- Clogged muffler

## BODY PANEL LOCATIONS ('13 MODEL)

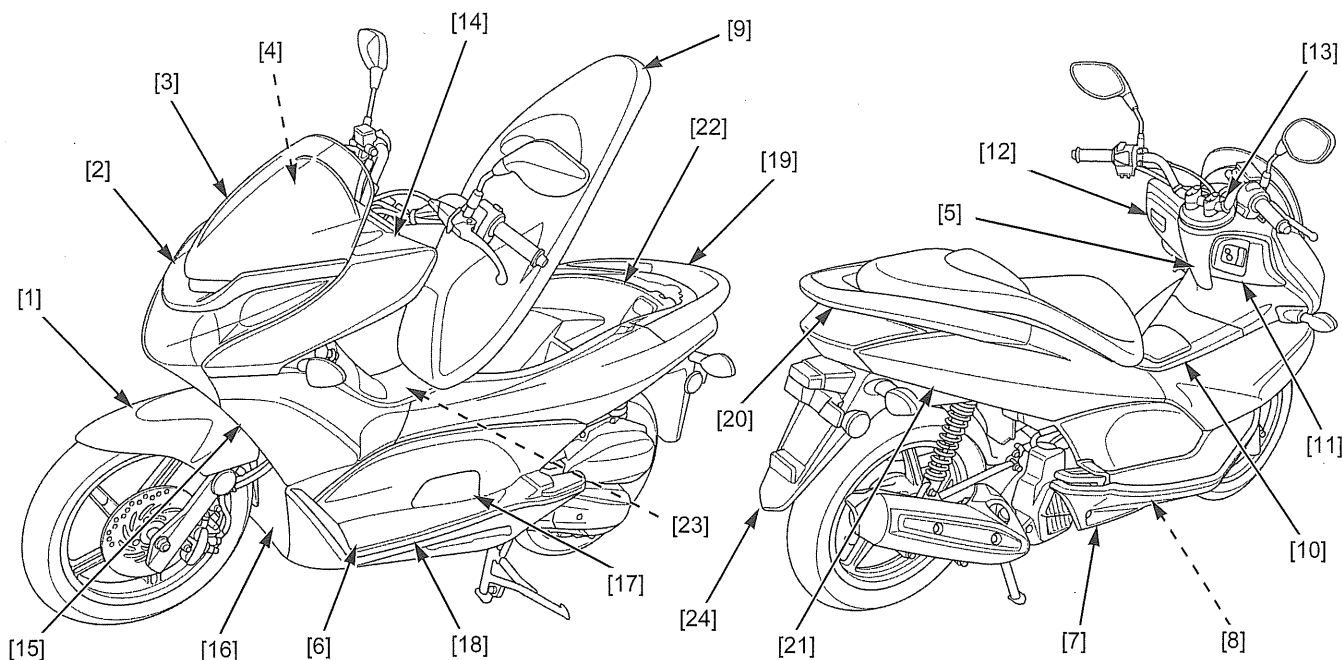

- |                                   |  |                                  |
|-----------------------------------|--|----------------------------------|
| [1] Front fender (page 2-5)       | [10] Center cover (page 2-10)                | [19] Grab rail cover (page 2-20) |
| [2] Front grille (page 2-5)       | [11] Right inner maintenance lid (page 2-11) | [20] Grab rail (page 2-21)       |
| [3] Meter visor (page 2-6)        | [12] Inner cover (page 2-13)                 | [21] Body cover (page 2-23)      |
| [4] Front meter panel (page 2-7)  | [13] Handlebar front cover (page 2-14)       | [22] Luggage box (page 2-25)     |
| [5] Meter panel cover (page 2-11) | [14] Rear meter panel (page 2-14)            | [23] Battery box (page 2-26)     |
| [6] Floor mat (page 2-7)          | [15] Front cover (page 2-15)                 | [24] Rear fender (page 2-27)     |
| [7] Side cover (page 2-8)         | [16] Front lower cover (page 2-17)           |                                  |
| [8] Under cover (page 2-9)        | [17] Plug maintenance lid (page 2-18)        |                                  |
| [9] Seat (page 2-10)              | [18] Floor step (page 2-19)                  |                                  |

## BODY PANEL REMOVAL CHART ('13 MODEL)

• This chart shows removal order of body panels by means of arrow.

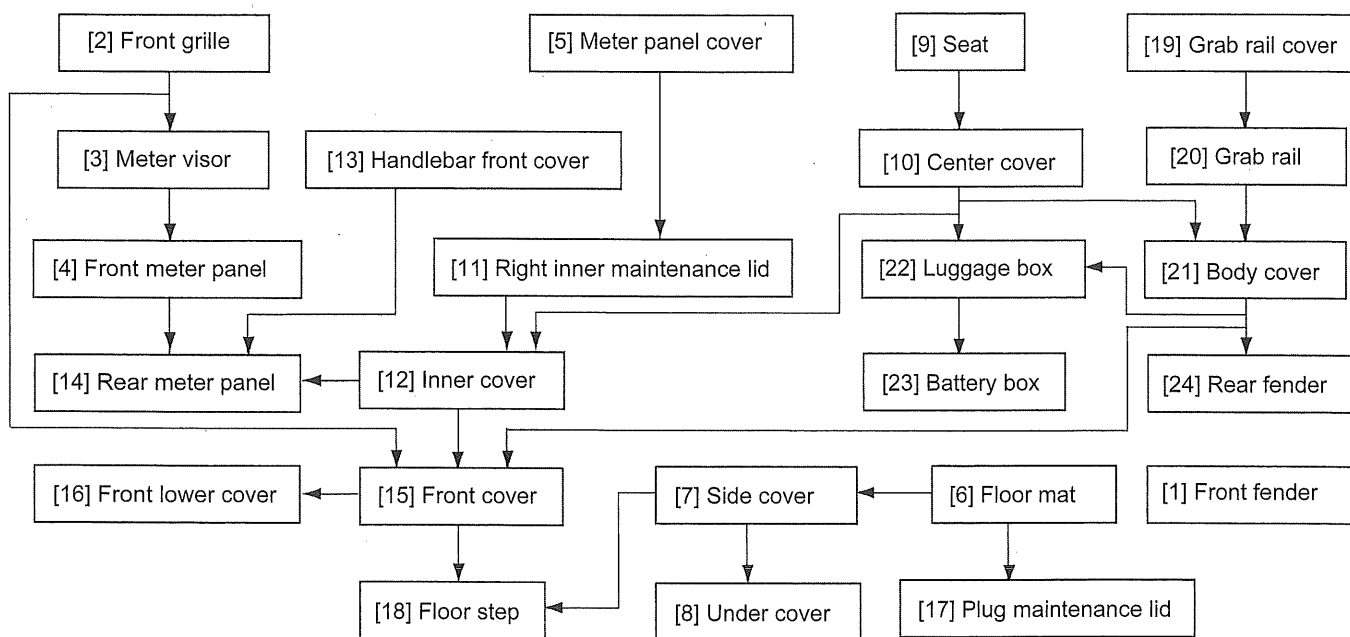

## BODY PANEL LOCATIONS (AFTER '13 MODEL)

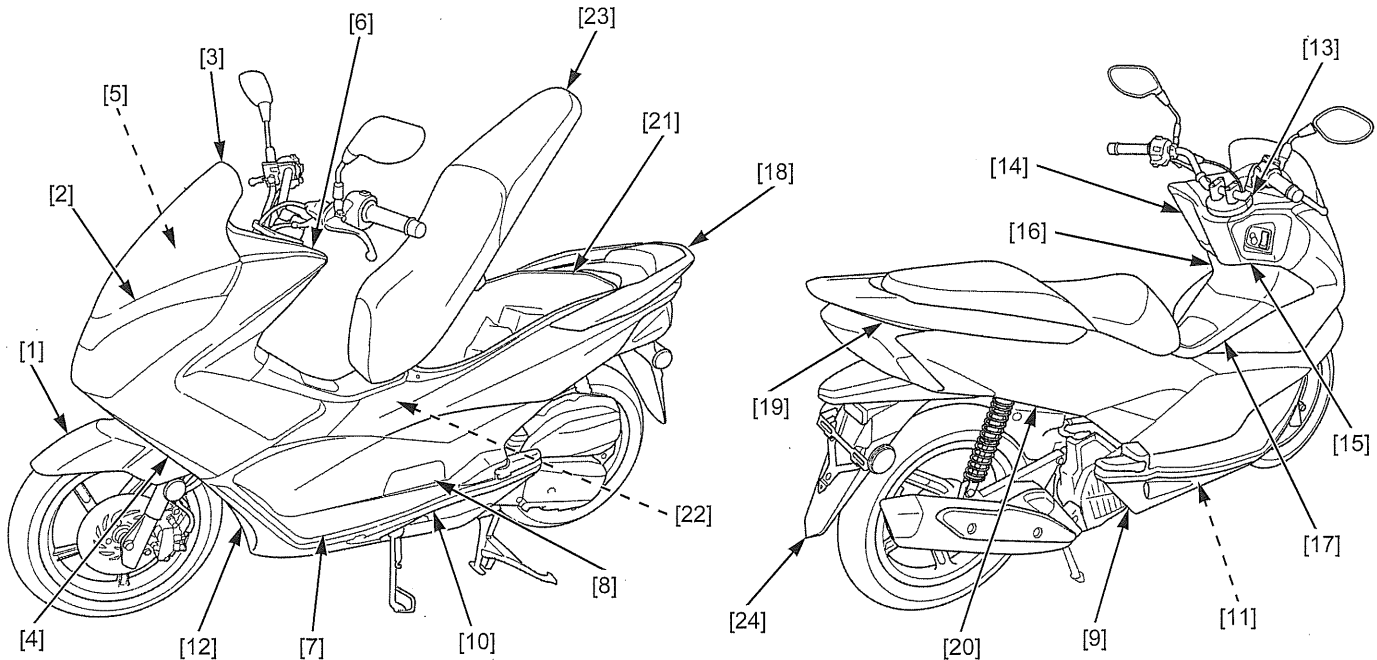

- |                                      |  |                              |
|--------------------------------------|--|------------------------------|
| [1] Front fender (page 2-5)          | [10] Floor step (page 2-19)              | [19] Grab rail (page 2-21)   |
| [2] Front grille (page 2-5)          | [11] Under cover (page 2-9)              | [20] Body cover (page 2-23)  |
| [3] Meter visor (page 2-6)           | [12] Front lower cover (page 2-17)       | [21] Luggage box (page 2-25) |
| [4] Front cover (page 2-15)          | [13] Handlebar front cover (page 2-14)   | [22] Battery box (page 2-26) |
| [5] Front meter panel (page 2-7)     | [14] Left inner outer cover (page 2-12)  | [23] Seat (page 2-10)        |
| [6] Rear meter panel (page 2-14)     | [15] Right inner outer cover (page 2-12) | [24] Rear fender (page 2-27) |
| [7] Floor mat (page 2-7)             | [16] Inner cover (page 2-13)             |                              |
| [8] Plug maintenance lid (page 2-18) | [17] Center cover (page 2-10)            |                              |
| [9] Side cover (page 2-8)            | [18] Grab rail cover (page 2-20)         |                              |

## BODY PANEL REMOVAL CHART (AFTER '13 MODEL)

• This chart shows removal order of body panels by means of arrow.

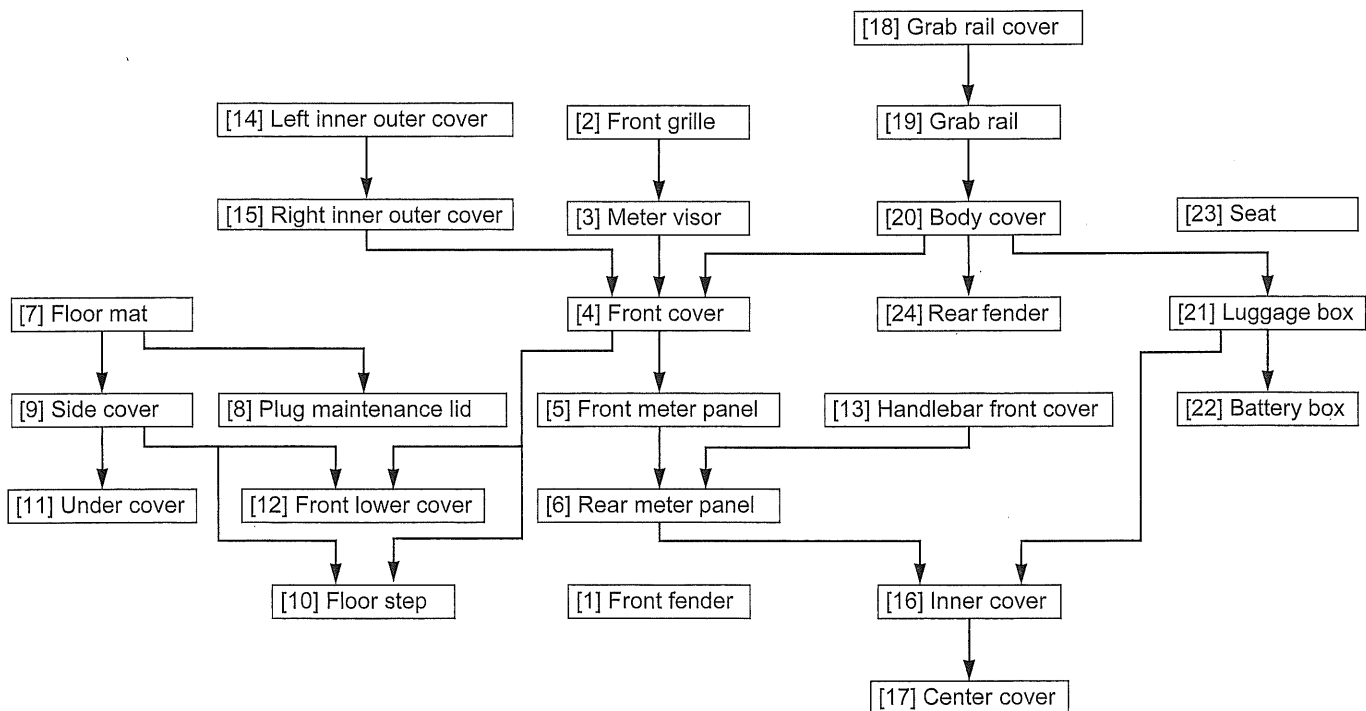

## FRONT FENDER

### REMOVAL/INSTALLATION ('13 MODEL)

Remove the following:

- Two bolts [1]
- Two nuts [2]/bolts [3]/reflex reflectors [4]
- Front fender [5]

Installation is in the reverse order of removal.

- Tighten the nut while aligning the reflex reflector with the boss of the fork slider.

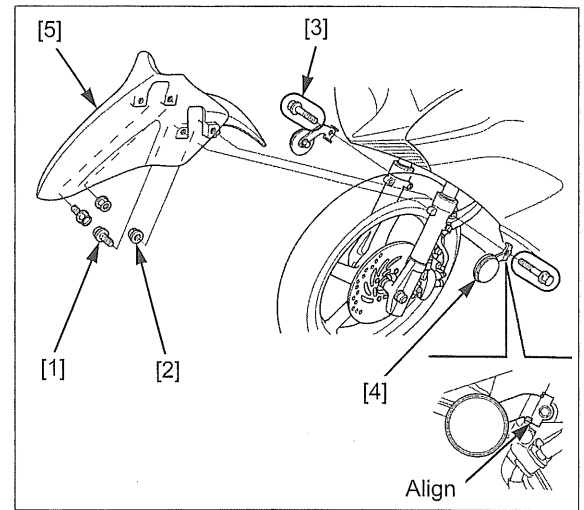

### REMOVAL/INSTALLATION (AFTER '13 MODEL)

Remove the front wheel (page 17-6).

- Two bolts [1]
- Two nuts [2]/bolts [3]/reflex reflectors [4]
- Front fender [5]

Installation is in the reverse order of removal.

- Tighten the nut while aligning the reflex reflector with the boss of the fork slider.

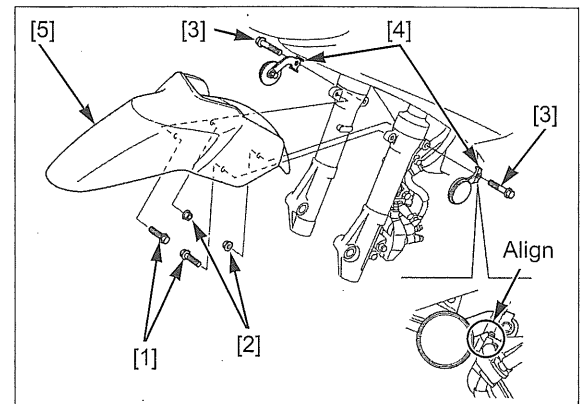

## FRONT GRILLE

### REMOVAL/INSTALLATION ('13 MODEL)

Remove the two screws [1].

Release the snap fit clips [2].

Pull the front grille [3] forward and release the hooks [4], then remove the front grille.

Installation is in the reverse order of removal.

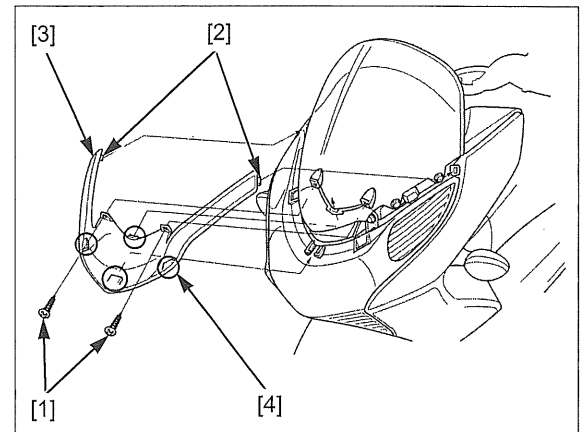

## FRAME/BODY PANELS/EXHAUST SYSTEM

### REMOVAL/INSTALLATION (AFTER '13 MODEL)

Remove the two screws [1].

Release the snap fit clips [2].

Pull the front grille [3] forward and release the hooks [4], then remove the front grille.

Installation is in the reverse order of removal.

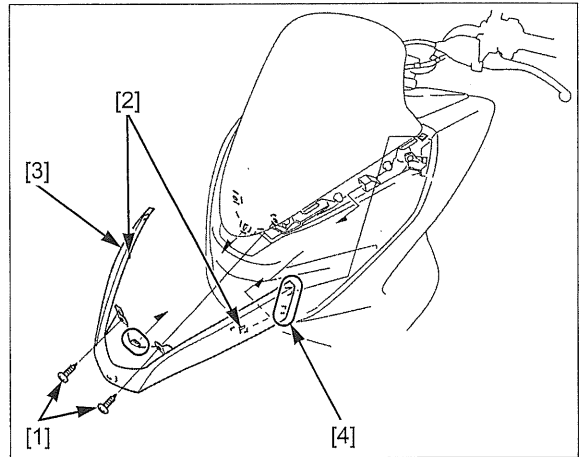

## METER VISOR

### REMOVAL/INSTALLATION ('13 MODEL)

Remove the front grille (page 2-5).

Remove the four bolts/washers [1], plastic washers [2] and meter visor [3].

Installation is in the reverse order of removal.

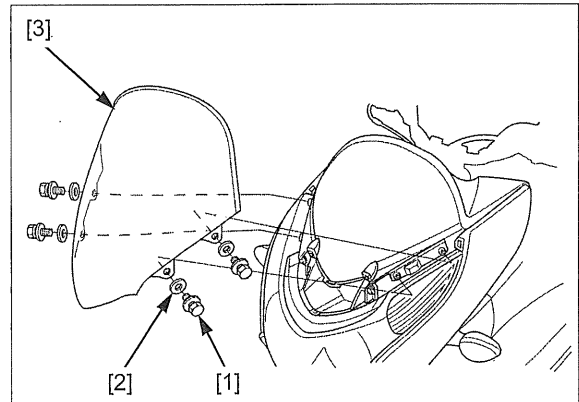

### REMOVAL/INSTALLATION (AFTER '13 MODEL)

Remove the front grille (page 2-5).

Remove the four bolts [1]/four plastic washers [2] and meter visor [3].

Installation is in the reverse order of removal.

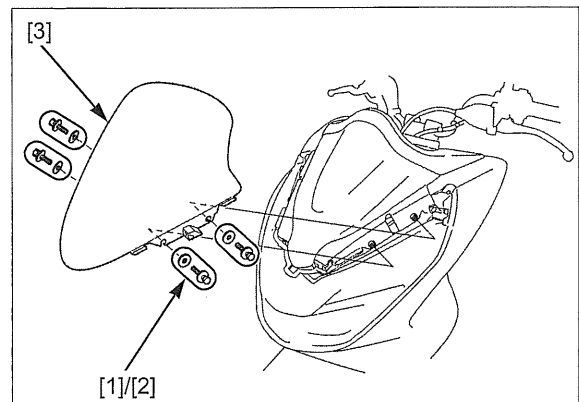

## FRONT METER PANEL

### REMOVAL/INSTALLATION ('13 MODEL)

Remove the meter visor (page 2-6).

Release the holes [1] of the front meter panel [2] from the bosses of the front cover stay.

Remove the front meter panel by releasing the hooks [3] from the holes of the rear meter panel.

Installation is in the reverse order of removal.

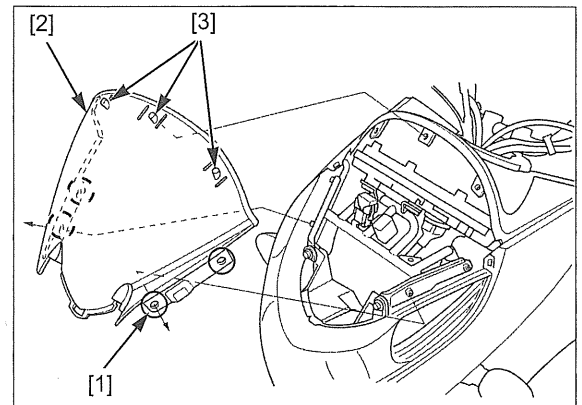

### REMOVAL/INSTALLATION (AFTER '13 MODEL)

Remove the front cover (page 2-15).

Release the holes [1] of the front meter panel [2] from the bosses of the front cover stay.

Remove the front meter panel by releasing the hooks [3] from the holes of the rear meter panel.

Installation is in the reverse order of removal.

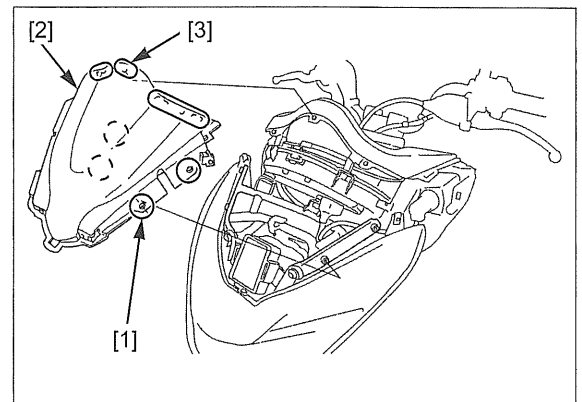

## FLOOR MAT

### REMOVAL/INSTALLATION ('13 MODEL)

Remove the floor mat [1] by releasing the bosses [2] of the reverse side from the holes of the floor step.

Installation is in the reverse order of removal.

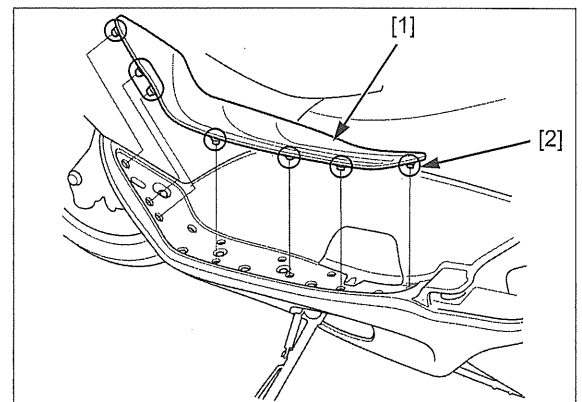

## FRAME/BODY PANELS/EXHAUST SYSTEM

### REMOVAL/INSTALLATION (AFTER '13 MODEL)

Remove the floor mat [1] by releasing the bosses [2] of the reverse side from the holes of the floor step.

Installation is in the reverse order of removal.

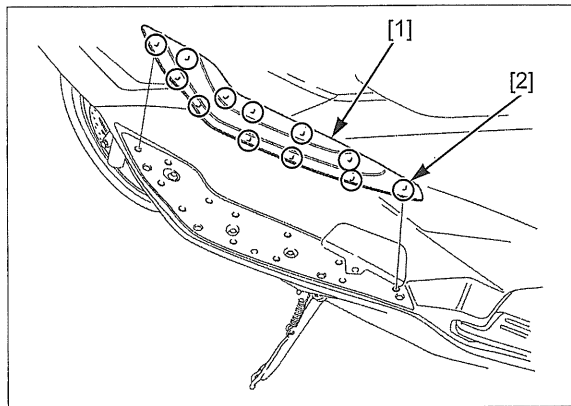

## SIDE COVER

### REMOVAL/INSTALLATION ('13 MODEL)

Remove the floor mat (page 2-7).

Place the scooter on its centerstand.

Open the passenger step and remove the special bolt [1].

Remove the following:

- Six tapping screws [2]
- Bolt/washer [3]

Remove the side cover [4] by releasing the following:

- Hook [5] from the slot of the under cover
- Three tabs [6] from the slots of the floor step

Installation is in the reverse order of removal.

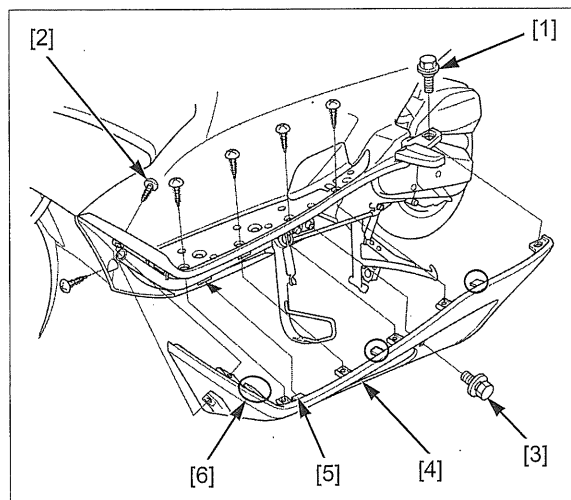

### REMOVAL/INSTALLATION (AFTER '13 MODEL)

Remove the floor mat (page 2-7).

Place the scooter on its centerstand.

Open the passenger step and remove the special bolt [1].

Remove the following:

- Two trim clip [2]
- Five screws (silver) [3]
- Screw (black) [4]
- Bolt/washer [5]

Remove the side cover [6] by releasing the following:

- Hook [7] from the slot of the under cover
- Tabs [8] from the slots of the floor step

Installation is in the reverse order of removal.

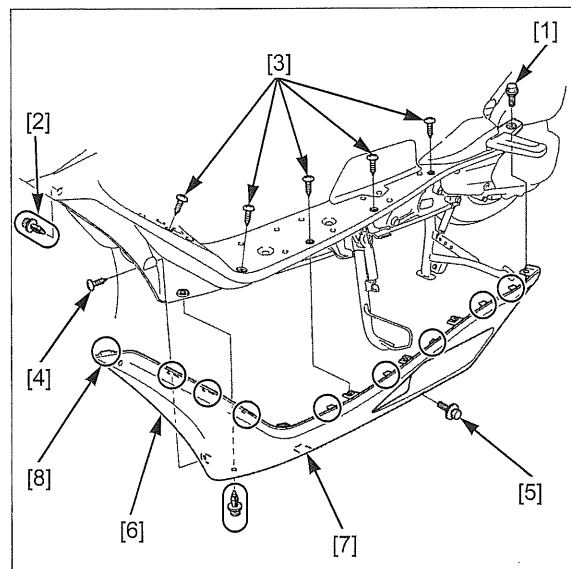



## UNDER COVER

### REMOVAL/INSTALLATION ('13 MODEL)

Remove the side covers (page 2-8).

Remove the four bolts/washers [1] and trim clip [2].

Release the three hoses [3] from the under cover [4] as shown.

Remove the under cover from the tabs [5] of the front lower cover.

Installation is in the reverse order of removal.

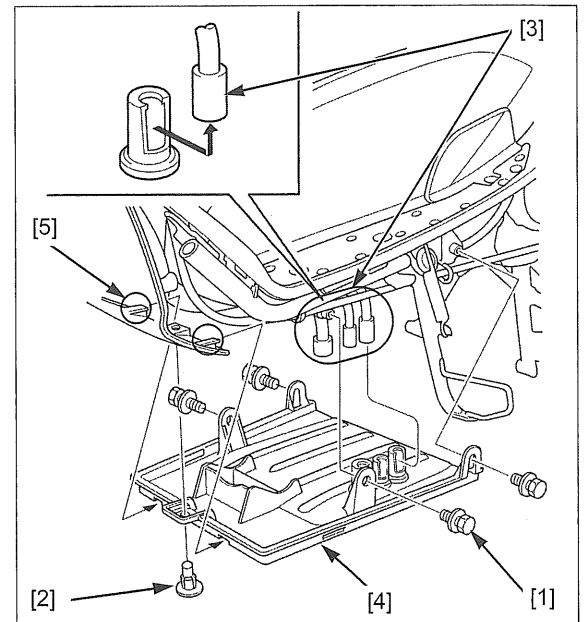

### REMOVAL/INSTALLATION (AFTER '13 MODEL)

Remove the side covers (page 2-8).

Remove the four bolts/washers [1] and trim clip [2].

Release the battery case drain hose [3] and EVAP canister drain hose (AC type only) [4] from the under cover [5].

Remove the under cover from the tabs [6] of the front lower cover.

Installation is in the reverse order of removal.

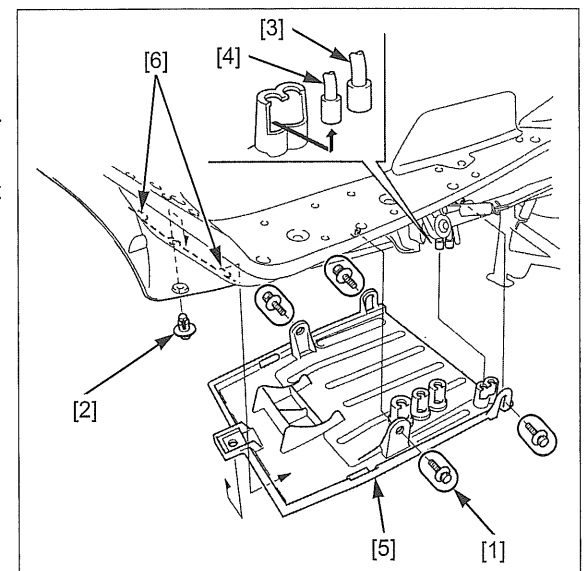

## SEAT

### REMOVAL/INSTALLATION ('13 MODEL)

Unlock and open the seat.

Remove the two bolts [1] and seat [2].

Install the seat and tighten the bolts so that the seat is completely centered.

- Apply grease to the seat hinge sliding area if necessary.

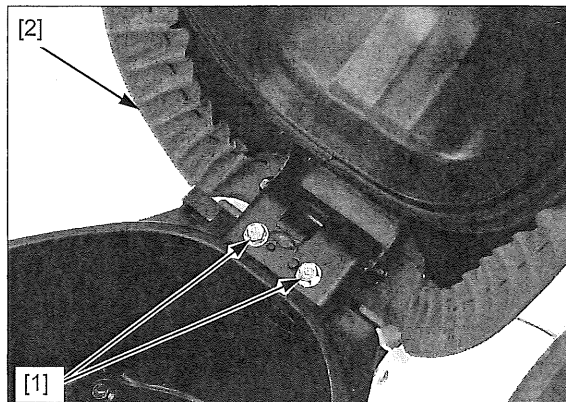

### REMOVAL/INSTALLATION (AFTER '13 MODEL)

Unlock and open the seat.

Remove the four nuts [1] and seat [2].

Remove the seat hinge [3] and seat hinge pin [4].

Install the seat and tighten the nuts so that the seat is completely centered.

**NOTE:**

- Apply grease to the seat hinge sliding area if necessary.

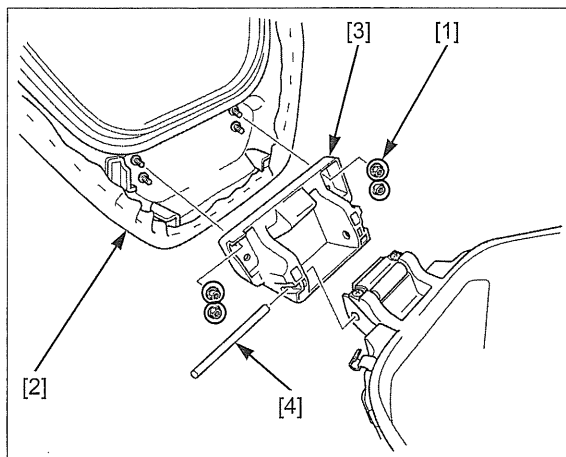

## CENTER COVER

### REMOVAL/INSTALLATION ('13 MODEL)

Remove the seat (page 2-10).

Unlock and open the fuel lid.

Remove the special screw [1].

Release the front side five tabs [2].

Pull the center cover [3] rearward and release the hooks [4].

Pull up the center cover and disconnect the fuel lid cable [5] as shown.

Installation is in the reverse order of removal.

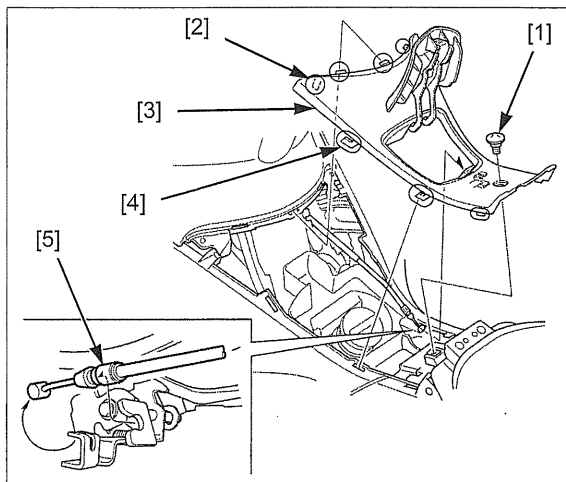

**REMOVAL/INSTALLATION (AFTER '13 MODEL)**

Remove the inner cover (page 2-13).

Remove the two screws [1].

Remove the center cover [2] from the inner cover [3].

Installation is in the reverse order of disassembly.

**NOTE:**

- Align the tabs of the inner upper cover with the slots of the inner lower cover.

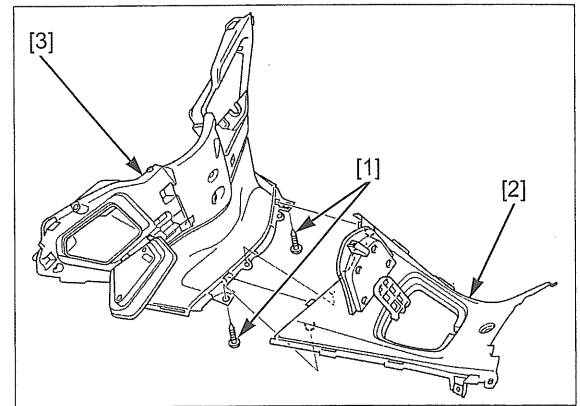

**METER PANEL COVER ('13 MODEL)**

**REMOVAL/INSTALLATION**

Release the both upper side hooks [1].

Remove the meter panel cover [2] by releasing the two snap fit clips [3] and lower side hook [4].

Installation is in the reverse order of removal.

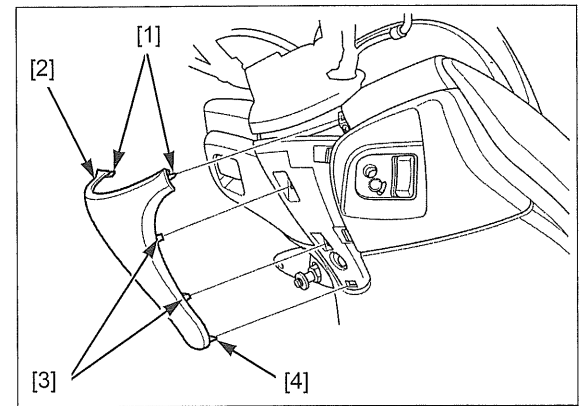

**RIGHT INNER MAINTENANCE LID ('13 MODEL)**

**REMOVAL/INSTALLATION**

Remove the meter panel cover (page 2-11).

Remove the right inner maintenance lid [1] by releasing the snap fit clips [2].

Installation is in the reverse order of removal.

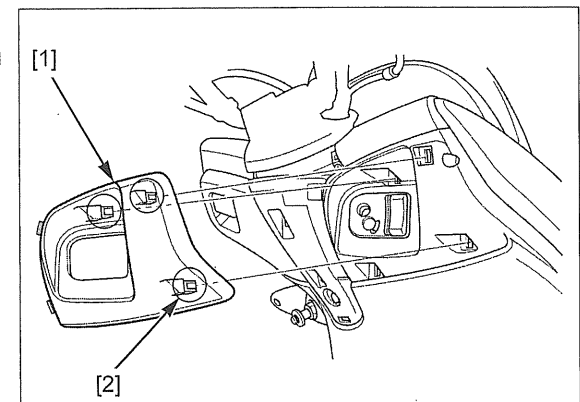

## LEFT INNER OUTER COVER (AFTER '13 MODEL)

### REMOVAL/INSTALLATION

Remove the left inner outer cover [1] by releasing the four snap fit clips [2] and hooks [3].

Installation is in the reverse order of removal.

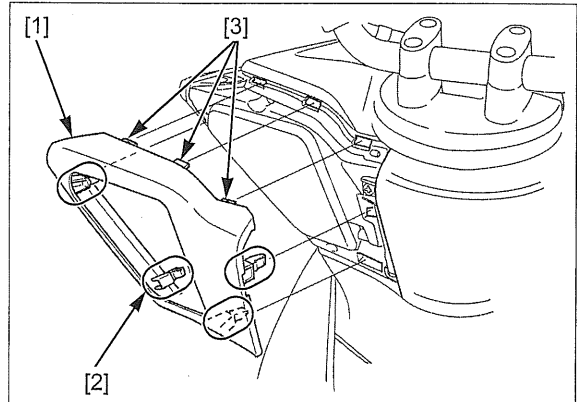

## RIGHT INNER OUTER COVER (AFTER '13 MODEL)

### REMOVAL/INSTALLATION

Remove the left inner outer cover (page 2-12).

Remove the two screws [1] and right inner outer cover [2] by releasing the four snap fit clips [3] and hooks [4].

Installation is in the reverse order of removal.

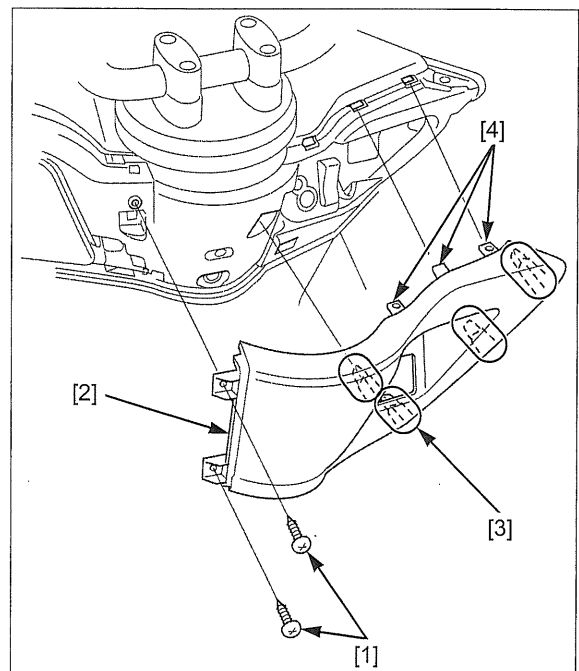

## INNER COVER

### REMOVAL/INSTALLATION ('13 MODEL)

Remove the following:

- Right inner maintenance lid (page 2-11)
- Center cover (page 2-10)

Release the bosses [1] of the front turn signal light rubber cover [2] from the grooves [3] of the inner cover as shown.

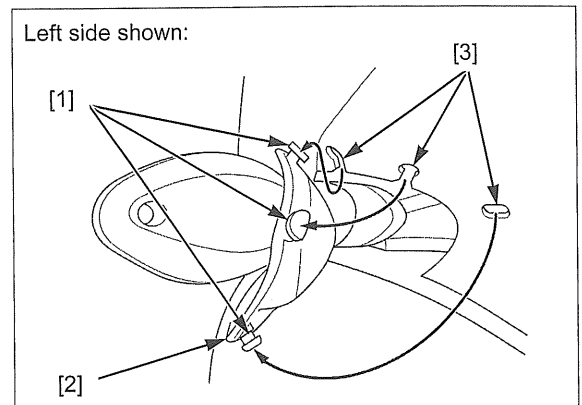

Remove the bolt [1].

Open the inner pocket and remove the six tapping screws [2].

Remove the inner cover [3] by releasing the following:

- Snap fit clips [4]
- Boss [5] from the grommet of the front cover stay
- Hooks [6] from the slots of the front cover
- Brake lock knob rubber cover hole [7] from the brake lock knob

Installation is in the reverse order of removal.

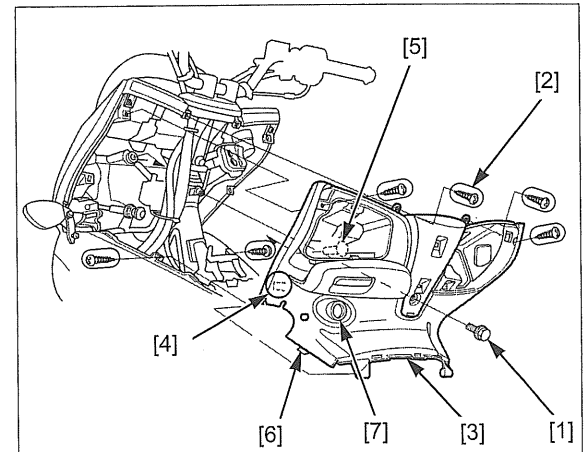

### REMOVAL/INSTALLATION (AFTER '13 MODEL)

Remove the following:

- Rear meter panel (page 2-14)
- Luggage box (page 2-25)

Remove the special screw [1], bolt [2] and inner cover [3].

Pull up the inner cover and disconnect the accessory socket connector [4] and fuel lid cable [5] as shown.

Installation is in the reverse order of removal.

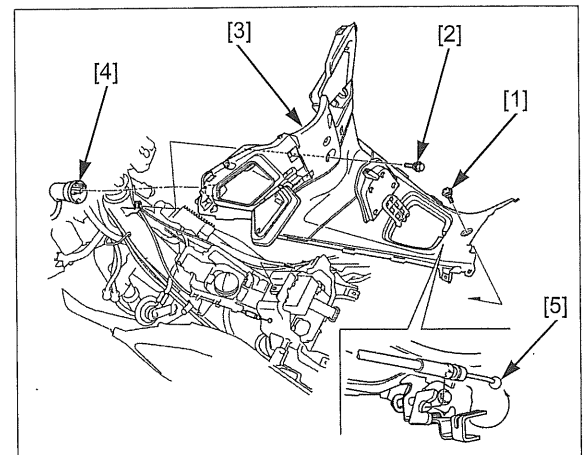

## HANDLEBAR FRONT COVER

### REMOVAL/INSTALLATION

Remove the two socket bolts [1]/plastic washers [2] and handlebar front cover [3].

Installation is in the reverse order of removal.

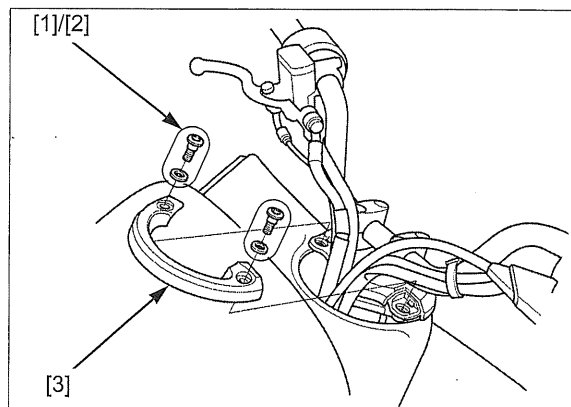

## REAR METER PANEL

### REMOVAL/INSTALLATION ('13 MODEL)

Remove the following:

- Front meter panel (page 2-7)
- Inner cover (page 2-13)
- Handlebar front cover (page 2-14)

Pull off the dust cover and disconnect the speedometer 20P connector [1].

Remove the four screws [2].

Remove the rear meter panel [3] by releasing the bosses [4] from the grommets of the front cover stay.

Installation is in the reverse order of removal.

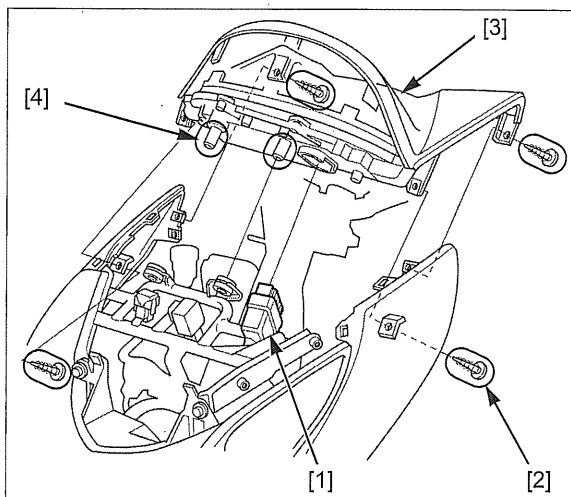

### REMOVAL/INSTALLATION (AFTER '13 MODEL)

Remove the following:

- Front meter panel (page 2-7)
- Handlebar front cover (page 2-14)

Disconnect the combination meter 16P connector [1].

Remove the rear meter panel [2] by releasing the inner cover [3] and bosses [4] from the grommets of the front cover stay.

Installation is in the reverse order of removal.

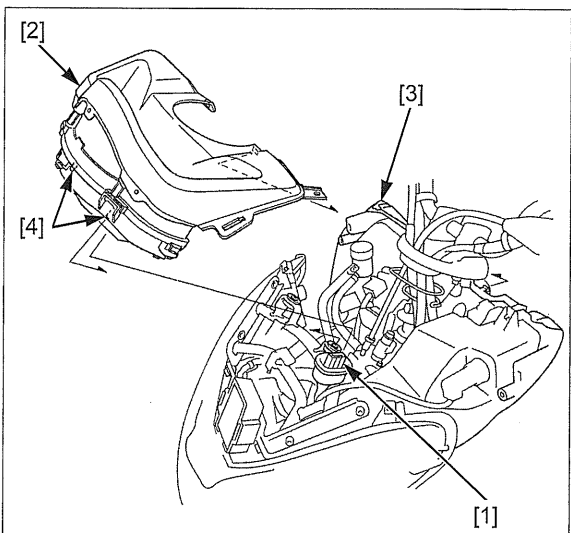

## FRONT COVER

### REMOVAL/INSTALLATION ('13 MODEL)

Remove the following:

- Front grille (page 2-5)
- Inner cover (page 2-13)
- Body cover (page 2-23)

*Left side:* Disconnect the left front turn signal light 2P (Black) connector [1].

*Right side:* Disconnect the right front turn signal light 2P connector [2].

Remove the six screws [3] and two screws/washers [4].

Remove the front cover [5] by releasing the following:

- Tab [6] from the groove of the headlight unit
- Hooks [7] from the slots of the floor step

Installation is in the reverse order of removal.

Left side:

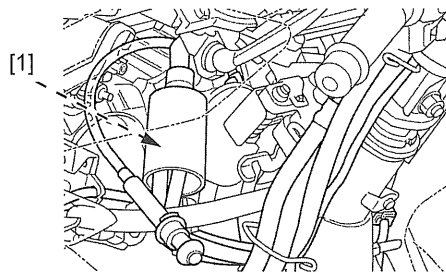

Right side:

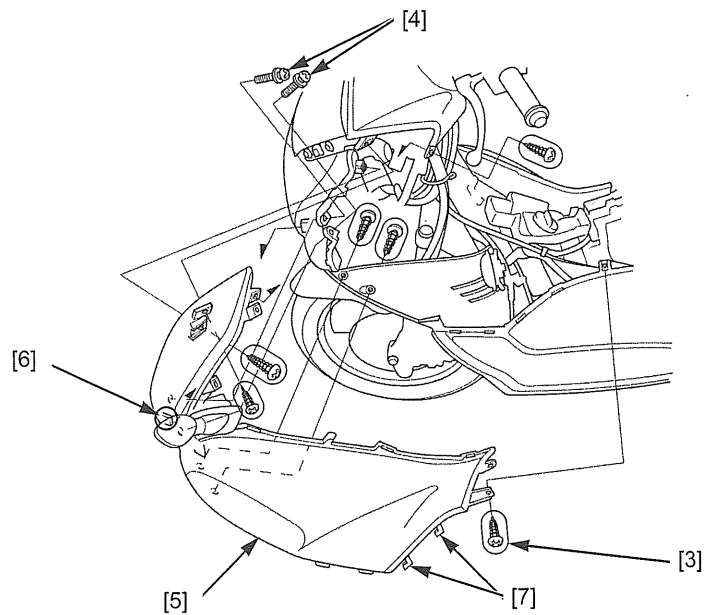
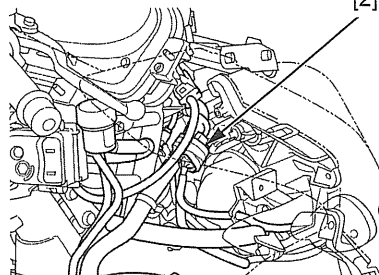

### REMOVAL/INSTALLATION (AFTER '13 MODEL)

Remove the following:

- Meter visor (page 2-6)
- Body cover (page 2-23)
- Right inner outer cover (page 2-12)

Remove the front center cover [1].

Remove the two trim clips [2] and fourteen screws (silver) [3].

Remove the right front cover [4] and left front cover [5] by releasing the following:

- Snap fit clip [6] from the slots of the inner cover
- Hooks [7] from the slots of the rear meter panel
- Hooks [8] from the slots of the floor step
- Tabs [9] from the slits of the center cover

Remove the two screws (black) [10] and combination light under cover [11].

Installation is in the reverse order of removal.

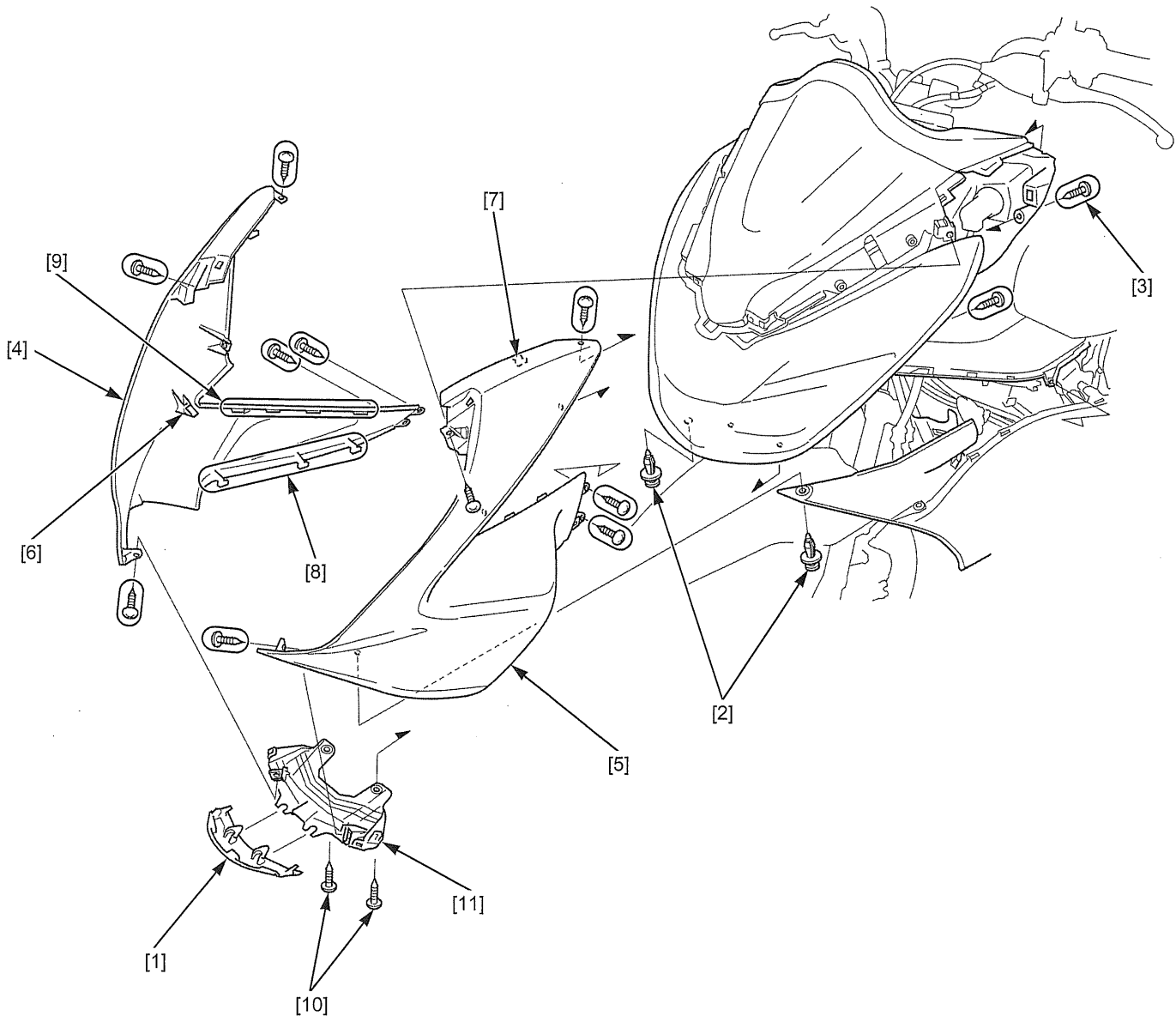



**DISASSEMBLY/ASSEMBLY ('13 MODEL)**

Release the following:

- Rubber cover boss [1] from the front cover hole [2].
- Front turn signal light wire [3] from the wire holder [4].

Remove the nut [5], set plate [6] and front turn signal light unit [7].

Remove the rubber cover [8] from the front turn signal light unit.

Remove the three screws [9] and front turn signal light unit stay [10] from the front cover.

Assembly is in the reverse order of disassembly.

**TORQUE: Front turn signal light unit mounting nut:**  
8.8 N·m (0.9 kgf·m, 6.5 lbf·ft)

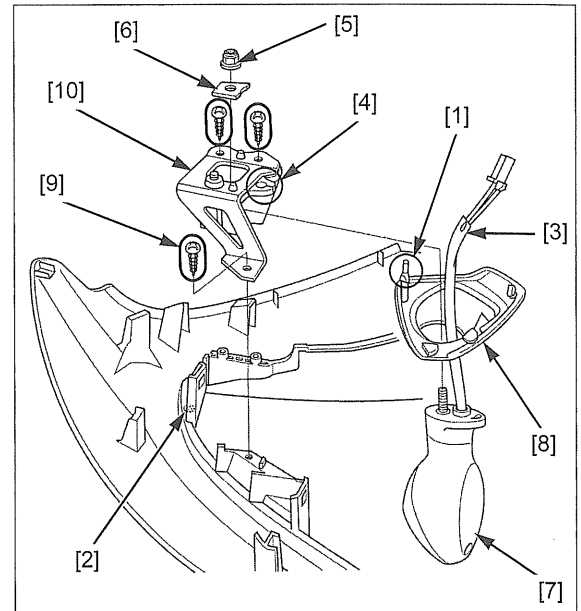

**FRONT LOWER COVER**

**REMOVAL/INSTALLATION ('13 MODEL)**

Remove the front cover (page 2-15).

Remove the four screws [1], bolt/washer [2] and trim clip [3].

Remove the front lower cover [4] by releasing the tabs [5] from the slots of the under cover.

Installation is in the reverse order of removal.

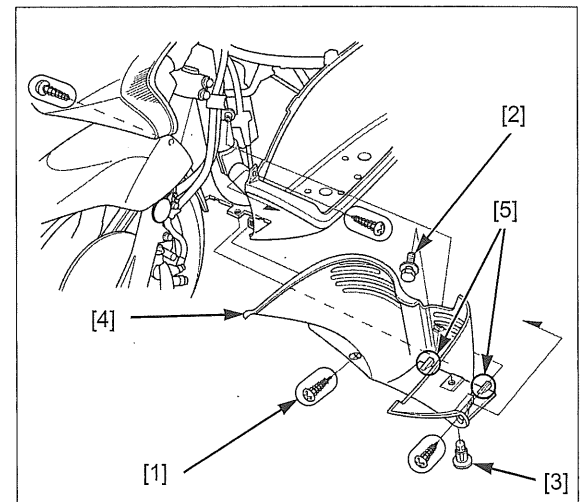

## FRAME/BODY PANELS/EXHAUST SYSTEM

### REMOVAL/INSTALLATION (AFTER '13 MODEL)

Remove the following:

- Front cover (page 2-15)
- Side cover (page 2-8)

Remove the three trim clips [1], bolt/washer [2] and front lower cover [3].

Installation is in the reverse order of removal.

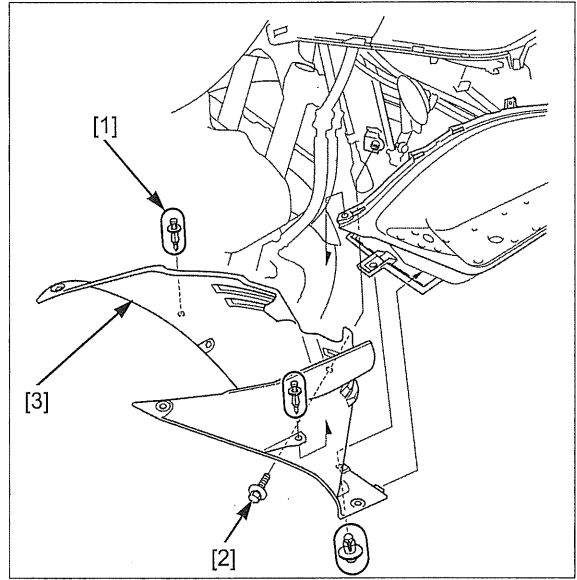

## PLUG MAINTENANCE LID

### REMOVAL/INSTALLATION ('13 MODEL)

Remove the left floor mat (page 2-7).

Remove the screw [1].

Remove the maintenance lid [2] by releasing the tabs [3].

Installation is in the reverse order of removal.

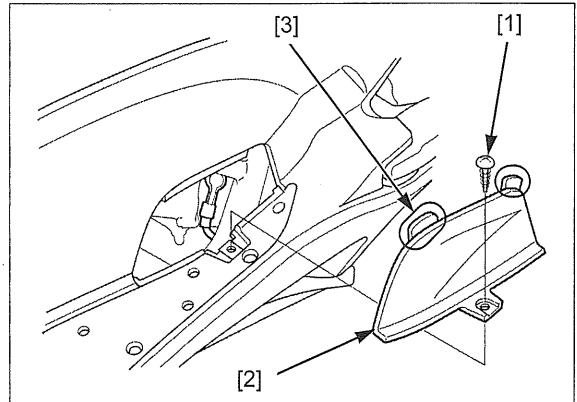

### REMOVAL/INSTALLATION (AFTER '13 MODEL)

Remove the left floor mat (page 2-7).

Remove the screw [1].

Remove the maintenance lid [2] by releasing the tabs [3].

Installation is in the reverse order of removal.

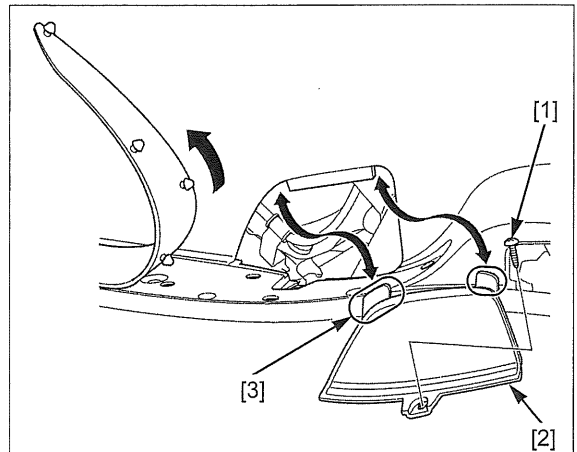

## FLOOR STEP

### REMOVAL/INSTALLATION ('13 MODEL)

Remove the following:

- Side cover (page 2-8)
- Front cover (page 2-15)

Remove the screw [1] and three special bolts [2].  
Open the passenger step [3] and remove the floor step [4].

Installation is in the reverse order of removal.

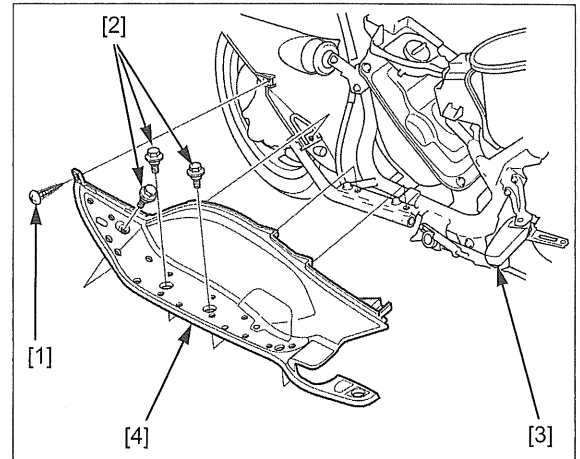

### REMOVAL/INSTALLATION (AFTER '13 MODEL)

Remove the following:

- Side cover (page 2-8)
- Front cover (page 2-15)

Remove the screw [1], trim clip [2] and three special bolts [3].

Remove the floor step [4].

Installation is in the reverse order of removal.

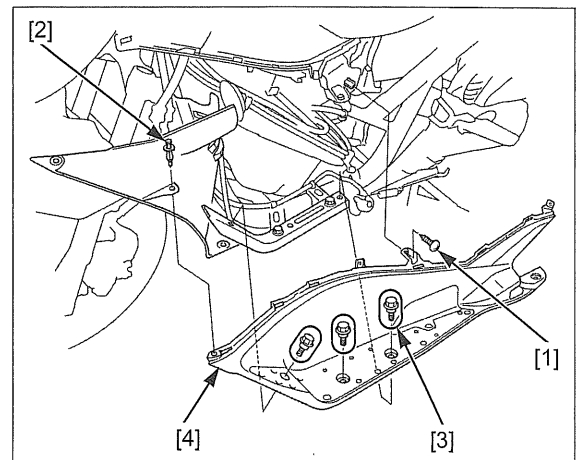

## GRAB RAIL COVER

### REMOVAL/INSTALLATION ('13 MODEL)

Unlock the seat with the seat opener.  
Open the seat.

Remove the two screws/washers [1].

Carefully pull up the front side of grab rail cover [2] and release the two snap fit clips [3].

Push the grab rail cover to outside and release the grooves [4] from the bosses [5] of the grab rail as shown.

Carefully pull up the rear side of grab rail cover and release the snap fit clip [6] and remove the grab rail cover.

Installation is in the reverse order of removal.

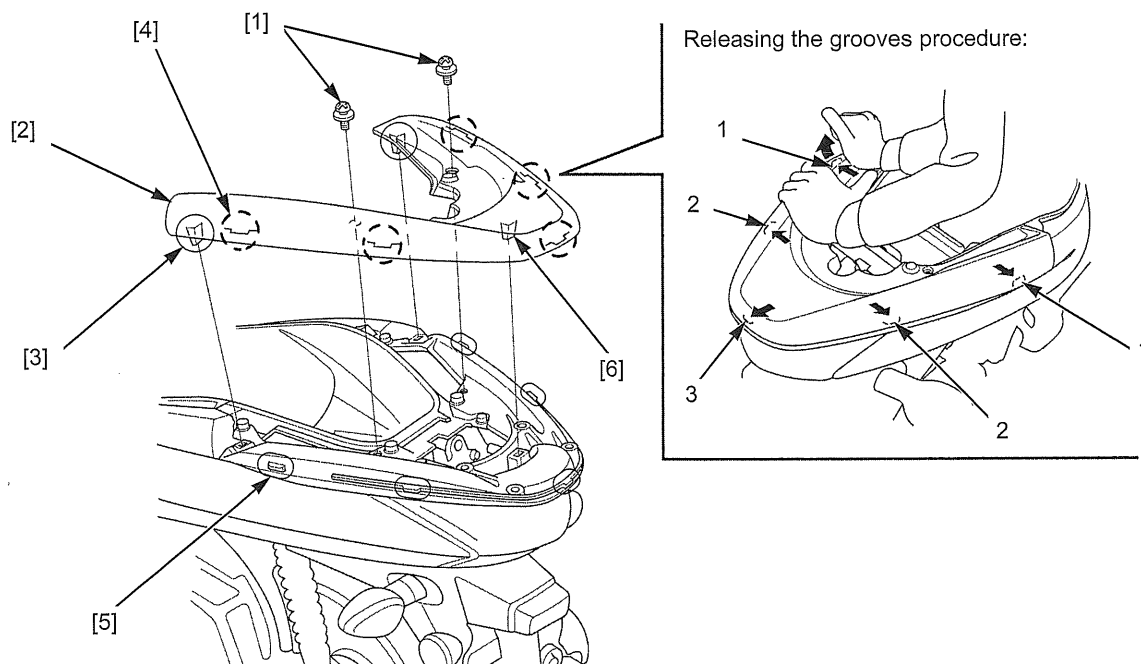

**REMOVAL/INSTALLATION (AFTER '13 MODEL)**

Unlock the seat with the seat opener.  
Open the seat.

Remove the two trim clips [1] and grab rail cover lid [2].

Remove the three screws [3].

Carefully pull up the front side of grab rail cover [4] and release the two snap fit clips [5] and remove the grab rail cover.

Installation is in the reverse order of removal.

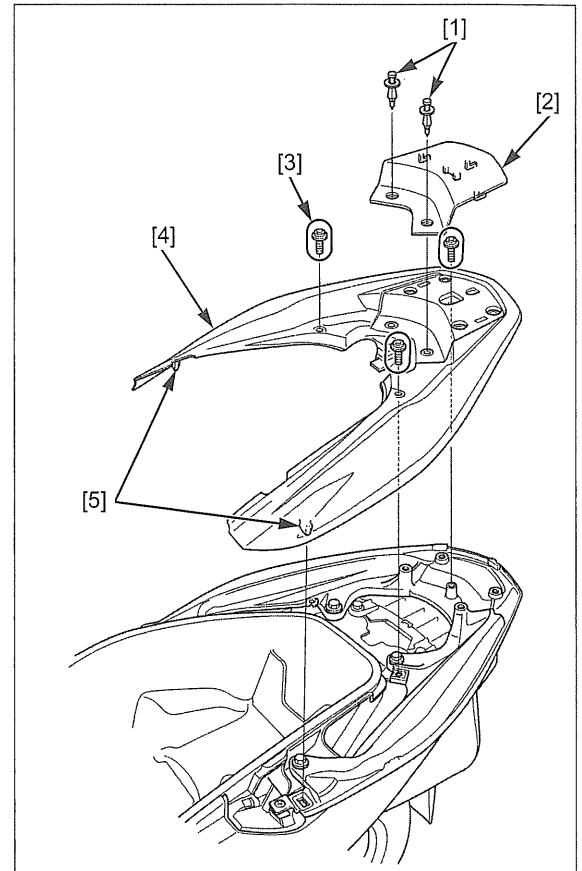

**GRAB RAIL**

**REMOVAL/INSTALLATION ('13 MODEL)**

Remove the grab rail cover (page 2-20).

Remove the four bolts [1].

Remove the grab rail [2] by releasing the bosses [3] from the grooves of the body cover as shown.

Installation is in the reverse order of removal.

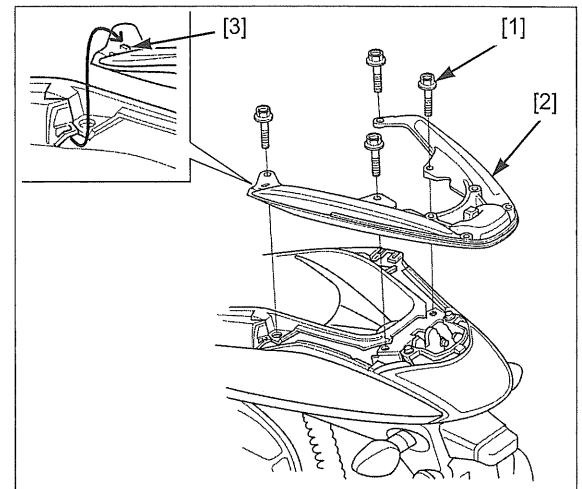

## FRAME/BODY PANELS/EXHAUST SYSTEM

### REMOVAL/INSTALLATION (AFTER '13 MODEL)

Remove the grab rail cover (page 2-20).

Remove the four bolts [1], two screws [2] and grab rail [3].

Installation is in the reverse order of removal.

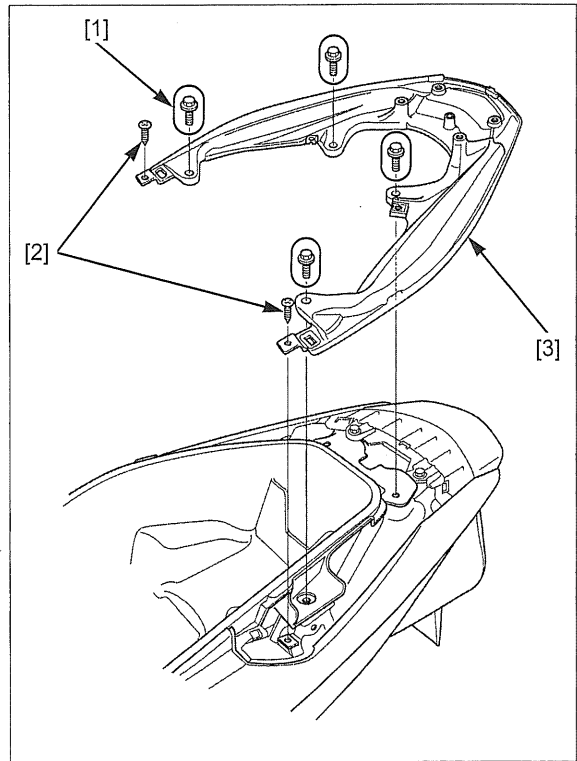

**BODY COVER****REMOVAL/INSTALLATION ('13 MODEL)**

Remove the following:

- Center cover (page 2-10)
- Grab rail (page 2-21)

Remove the two bolts/washers [1] and eight tapping screws [2].

Slightly slide the body cover [3] backward and release the following:

- Lower side holes [4] from the cone plugs [5] of the frame
- Hooks [6] from the slots
- Groove [7] from the stopper of the tail/brake light unit

Pull the body cover backward and disconnect the brake/tail light 6P connector [8], then remove the body cover.

Installation is in the reverse order of removal.

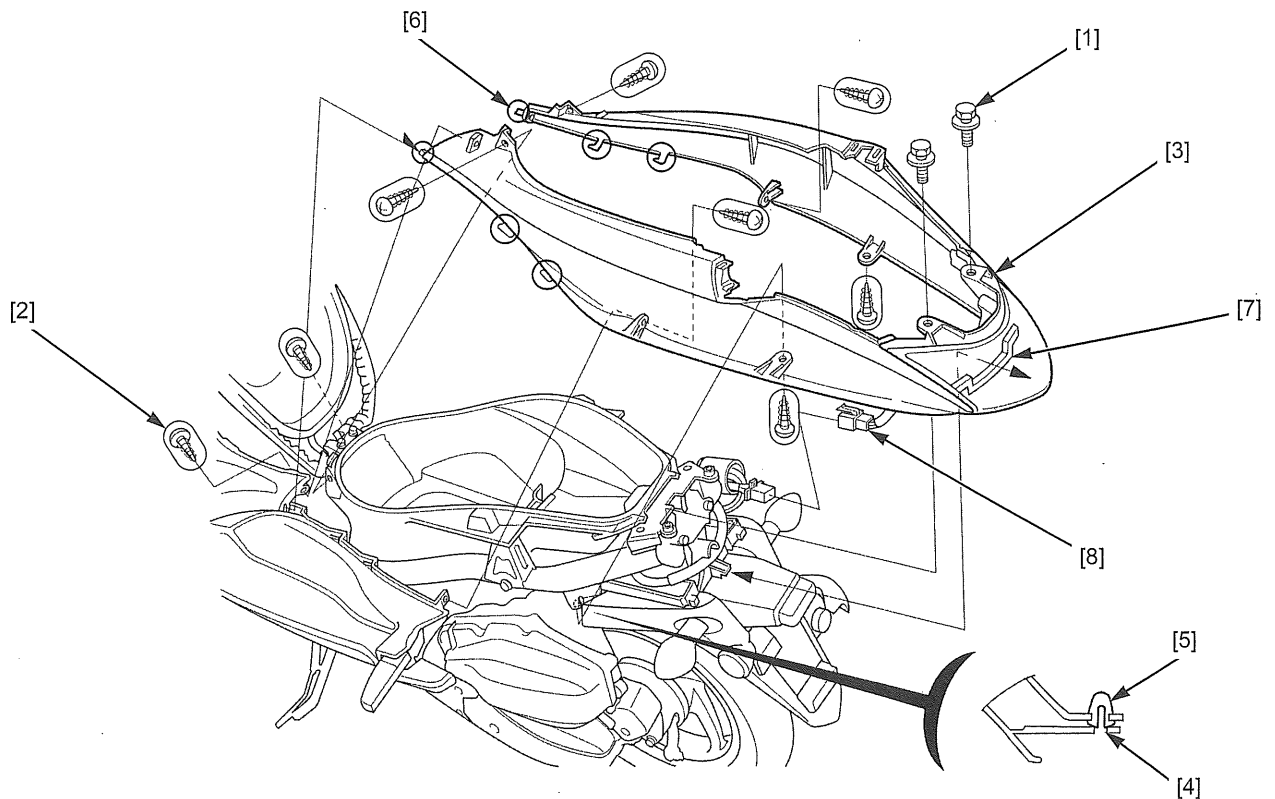

## FRAME/BODY PANELS/EXHAUST SYSTEM

### REMOVAL/INSTALLATION (AFTER '13 MODEL)

Remove the grab rail (page 2-21)

Remove the following:

- Two bolt/washer [1]
- Two screws (long) [2]
- Two screws (short) [3]
- Four trim clips [4]

Slightly slide the body cover [5] backward and release the following:

- Snap fit clips [6] from the slots of the front cover
- Hooks [7] from the slots of the floor step
- Tabs [8] from the slits of the center cover
- Bosses [9] from the grommets of the rear fender

Pull the body cover backward and disconnect the rear combination light 9P connector [10], then remove the body cover.

Installation is in the reverse order of removal.

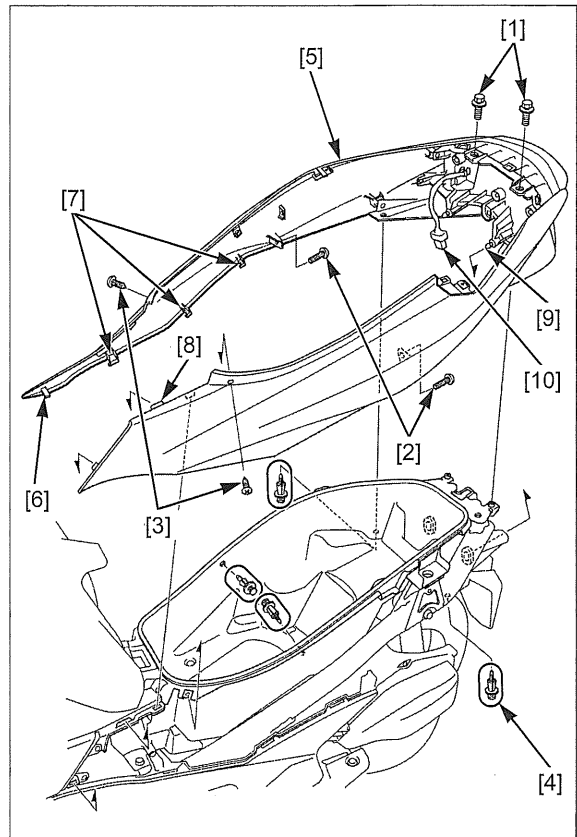

### DISASSEMBLY/ASSEMBLY ('13 MODEL)

Remove the following:

- Four tapping screws [1]
- Right/left body covers [2]
- Tail/brake light unit [3]

Assembly is in the reverse order of disassembly.

#### TORQUE:

Tail/brake light unit mounting screw:  
1 N·m (0.1 kgf·m, 0.7 lbf·ft)

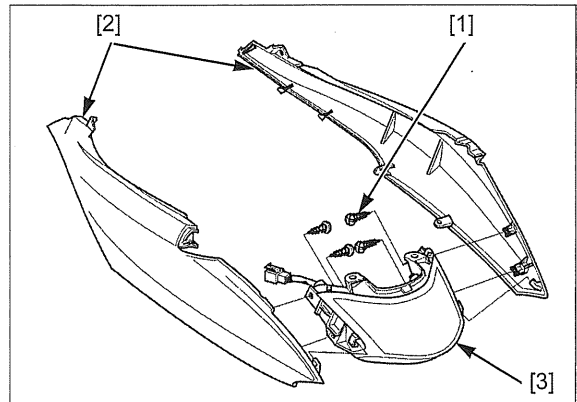



**DISASSEMBLY/ASSEMBLY (AFTER '13 MODEL)**

Remove the following:

- Two screws [1]
- Right/left body covers [2]
- License light cover [3]
- Five rear comb light Assy. mounting screws [4]
- Rear comb light Assy. [5]

Assembly is in the reverse order of disassembly.

**TORQUE:**

**Rear comb light unit mounting screw:**  
 1.2 N·m (0.12 kgf·m, 0.9 lbf·ft)

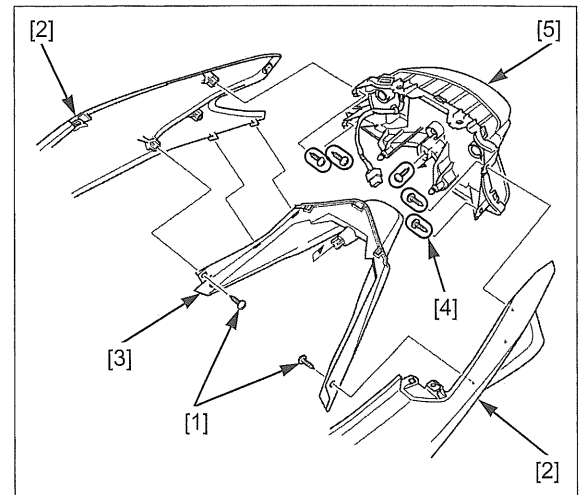

**LUGGAGE BOX**

**REMOVAL/INSTALLATION ('13 MODEL)**

Remove the following:

- Center cover (page 2-10)
- Body cover (page 2-23)
- Battery maintenance lid (page 20-7)

Release the battery band [1].

Remove the following:

- Two bolts/washers [2]
- Four special bolts [3]
- Luggage box [4]

Installation is in the reverse order of removal.

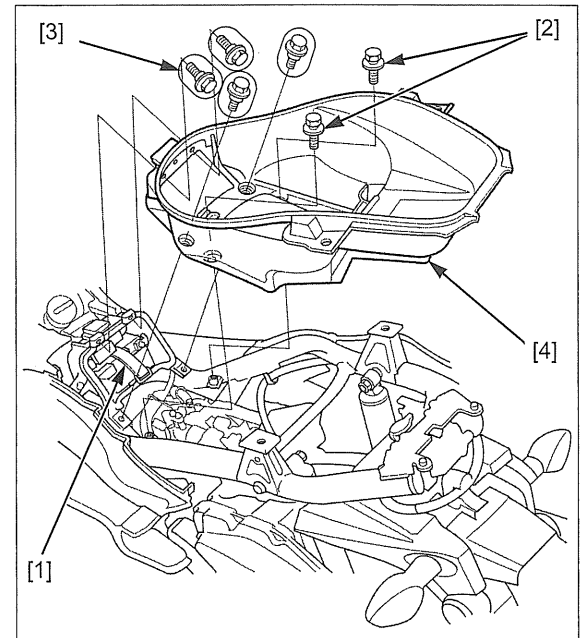

## FRAME/BODY PANELS/EXHAUST SYSTEM

### REMOVAL/INSTALLATION (AFTER '13 MODEL)

Remove the body cover (page 2-23).

Remove the battery maintenance lid [1].

Release the battery band [2].

Unhook the seat lock cable [3] from luggage box [4].

Remove the following:

- Two luggage box nuts [5]
- Two Insert bolts [6]
- Two bolts/washers [7]
- Two special bolts [8]
- Luggage box

Installation is in the reverse order of removal.

#### TORQUE:

**Luggage box nut:**

**3 N·m (0.3 kgf·m, 2.2 lbf·ft)**

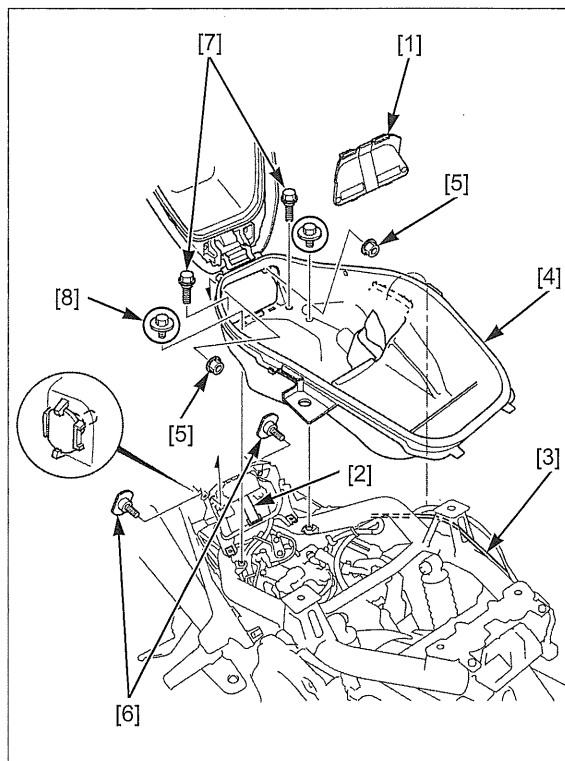

## BATTERY BOX

### REMOVAL/INSTALLATION ('13 MODEL)

Remove the following:

- Luggage box (page 2-25)
- Battery (page 20-7)

Remove the wire band boss [1] and disconnect the battery box drain hose [2] from the joint.

Release the EVAP canister-to-intake pipe hose [3] from the case grooves.

Remove the two special bolts [4].

Remove the battery box [5] by pulling out the main wire harness [6].

Installation is in the reverse order of removal.

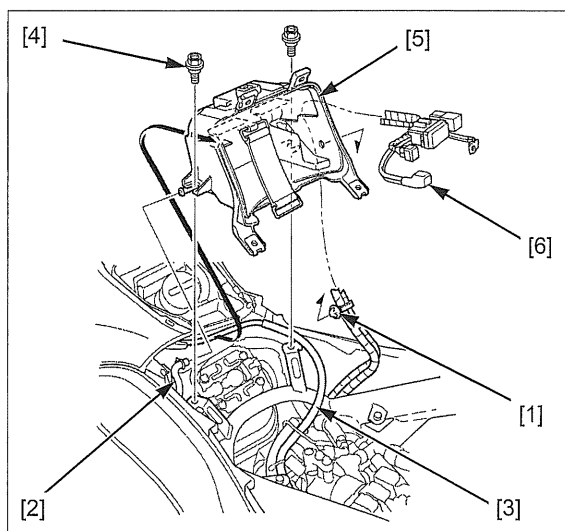

**REMOVAL/INSTALLATION (AFTER '13 MODEL)**

Remove the following:

- Luggage box (page 2-25)
- Battery (page 20-7)

Remove the battery band [1], fuse box [2] and disconnect the battery box drain hose [3] from the joint.

Remove the two special bolts [4], special screw [5] and two screws [6].

Remove the battery box [7] by pulling out the main wire harness.

Installation is in the reverse order of removal.

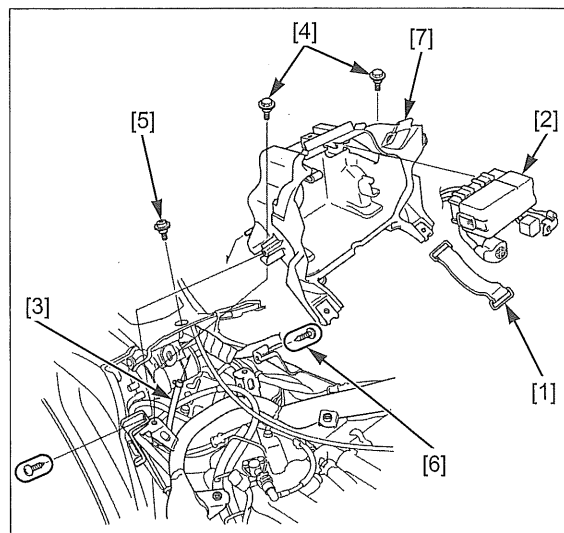

**REAR FENDER**

**REMOVAL/INSTALLATION ('13 MODEL)**

Remove the body cover (page 2-23).

Disconnect the following connectors:

- Turn signal light (Light blue, Orange, Green) wire connectors [1]
- License light (Brown, Green) wire connectors [2]

Release the radiator siphon hose [3] from the hose groove [4].

Remove the three bolts/washers [5].

Remove the rear fender [6] from the frame bosses [7] and boss [8] of the radiator reserve tank.

Installation is in the reverse order of removal.

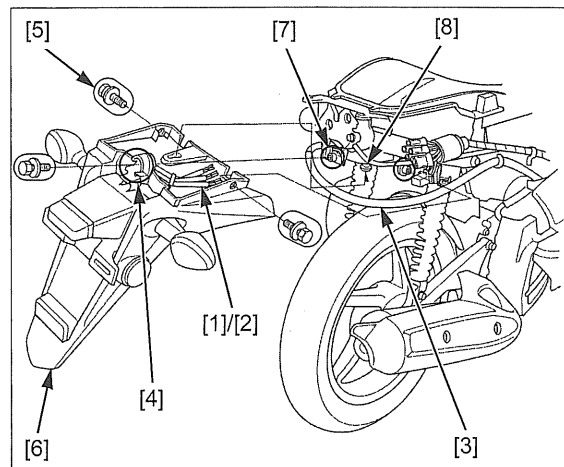

**REMOVAL/INSTALLATION (AFTER '13 MODEL)**

Remove the body cover (page 2-23).

Disconnect the License light 2P connector [1].

Remove the three bolts/washers [2] and rear fender [3].

Remove the nuts [4], collars [5], and number plate bracket [6].

Installation is in the reverse order of removal.

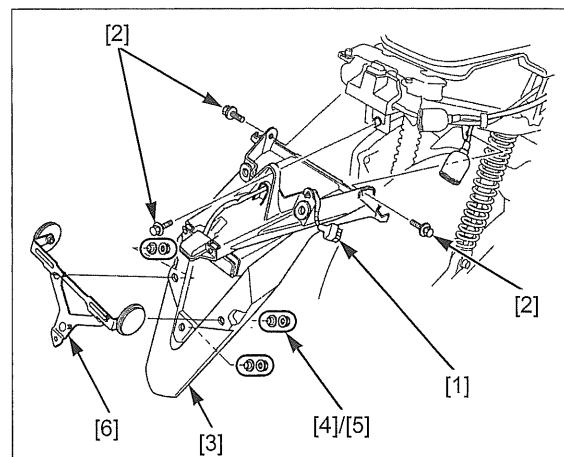

## EXHAUST PIPE/MUFFLER

### REMOVAL/INSTALLATION

Remove the joint nuts [1].

Remove the three muffler mounting bolts [2] and exhaust pipe/muffler [3].

Remove the gasket [4] from the exhaust pipe.

Installation is in the reverse order of removal.

- Always replace the gasket with a new one.
- Tighten the exhaust pipe joint nuts first, then tighten the muffler mounting bolts.
- After installation, start the engine and inspect the exhaust system for leaks.

#### TORQUE:

**Exhaust pipe joint nut:**  
29 N·m (3.0 kgf·m, 21 lbf·ft)

**Muffler mounting bolt:**  
49 N·m (5.0 kgf·m, 36 lbf·ft)

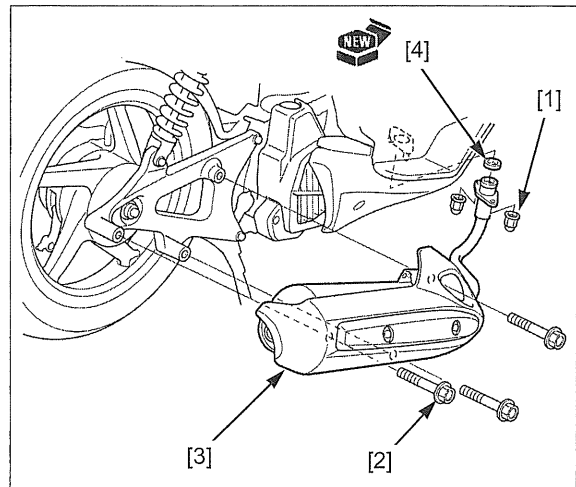

### EXHAUST PIPE STUD BOLT REPLACEMENT

Thread two nuts to the stud bolt and tighten them together, then use a wrench on them to turn the stud bolt out.

*Install the stud bolts with their rounded end [1] facing out.*

Install and tighten new stud bolts into the cylinder head to the specified torque.

**TORQUE: 9 N·m (0.92 kgf·m, 6.6 lbf·ft)**

After tightening the stud bolts, check that the length from the bolt head to the cylinder head surface is within specification.

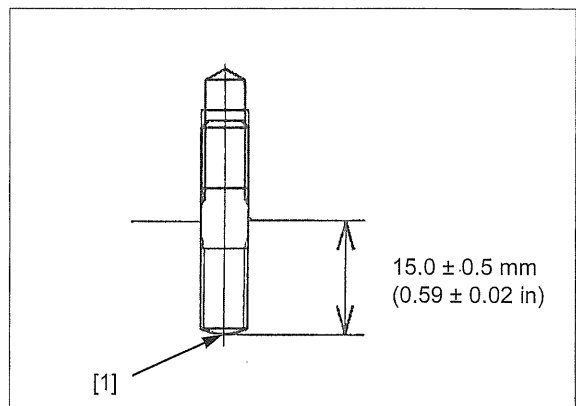

## CENTERSTAND

### REMOVAL/INSTALLATION

Retract the centerstand and support the scooter securely.

Remove the centerstand spring [1].

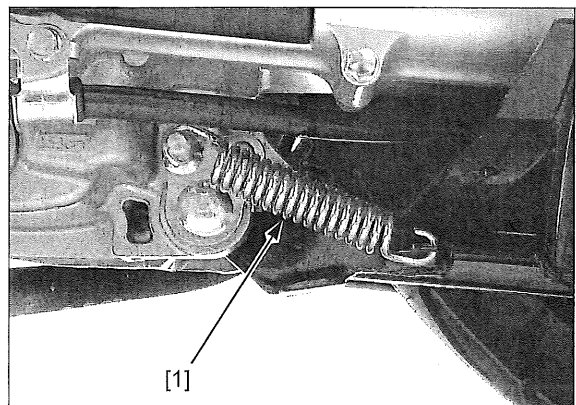

## FRAME/BODY PANELS/EXHAUST SYSTEM

Remove the cotter pin [1] and washer [2].  
Pull out the pivot shaft [3] and remove the centerstand [4].

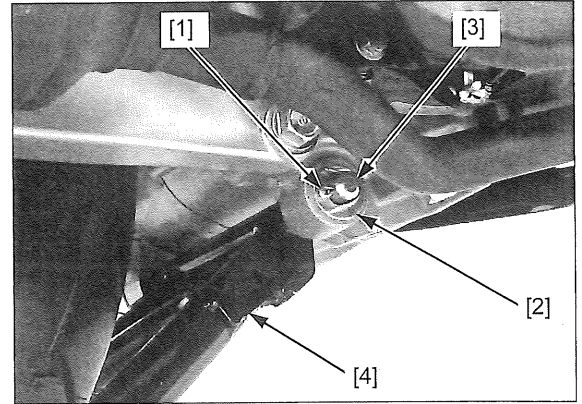

Apply thin coat of grease to the centerstand pivot shaft [1] surface.

Install the centerstand [2] and insert the pivot shaft while aligning its hole with the crankcase boss.

Install the washer [3] and a new cotter pin [4].

Install the centerstand spring in the reverse order of removal.

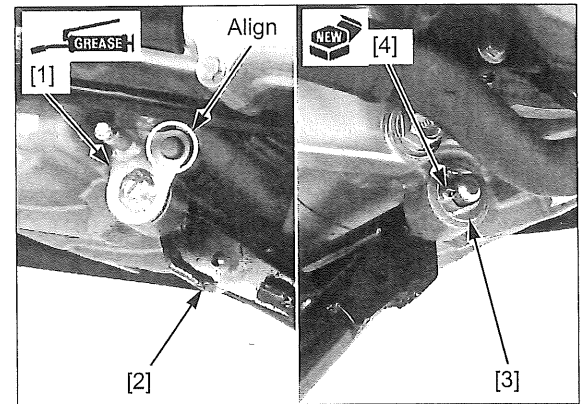

---

**MEMO**

---

# 3. MAINTENANCE

---

SERVICE INFORMATION.....	3-2	EVAPORATIVE EMISSION CONTROL SYSTEM (EXCEPT AFTER '13 MODEL CM TYPE).....	3-15
MAINTENANCE SCHEDULE ('13 MODEL).....	3-4	DRIVE BELT.....	3-15
MAINTENANCE SCHEDULE (AFTER '13 MODEL).....	3-5	FINAL DRIVE OIL.....	3-16
FUEL LINE.....	3-6	BRAKE FLUID.....	3-17
THROTTLE OPERATION.....	3-6	BRAKE SHOES/PADS WEAR.....	3-17
AIR CLEANER.....	3-7	BRAKE SYSTEM.....	3-18
CRANKCASE BREATHER.....	3-8	BRAKE LIGHT SWITCH.....	3-20
SPARK PLUG.....	3-9	BRAKE LOCK OPERATION.....	3-21
VALVE CLEARANCE.....	3-10	HEADLIGHT AIM.....	3-22
ENGINE OIL.....	3-11	CLUTCH SHOES WEAR.....	3-23
ENGINE OIL STRAINER SCREEN.....	3-12	SIDESTAND.....	3-23
ENGINE IDLE SPEED.....	3-13	SUSPENSION.....	3-23
RADIATOR COOLANT.....	3-13	NUTS, BOLTS, FASTENERS.....	3-24
COOLING SYSTEM.....	3-14	WHEELS/TIRES.....	3-24
		STEERING HEAD BEARINGS.....	3-25

## MAINTENANCE

# SERVICE INFORMATION

## GENERAL

- Gasoline is extremely flammable and is explosive under certain conditions. Work in a well ventilated area. Smoking or allowing flames or sparks in the work area or where the gasoline is stored can cause a fire or explosion.
- If the engine must be running to do some work, make sure the area is well ventilated. Never run the engine in an enclosed area. The exhaust contains poisonous carbon monoxide gas that may cause loss of consciousness and may lead to death. Run the engine in an open area or with an exhaust evacuation system in an enclosed area.
- Place the scooter on a level ground before starting any work.

## SPECIFICATIONS

ITEM		SPECIFICATIONS	
Throttle grip freeplay		2 – 6 mm (0.1 – 0.2 in)	
Spark plug		CPR7EA-9 (NGK)	
Spark plug gap		0.8 – 0.9 mm (0.03 – 0.04 in)	
Valve clearance	IN	0.10 ± 0.02 (0.004 ± 0.001)	
	EX	0.24 ± 0.02 (0.009 ± 0.001)	
Recommended engine oil		Pro Honda HP4M 4-stroke oil (U.S.A. and Canada) or equivalent motor oil API service classification: SJ or higher JASO T 903 standard: MB Viscosity: SAE 10W-30	
Engine oil capacity	After draining	0.8 liter (0.8 US qt, 0.7 Imp qt)	
	After disassembly	0.9 liter (1.0 US qt, 0.8 Imp qt)	
	After oil strainer removal	0.9 liter (1.0 US qt, 0.8 Imp qt)	
Engine idle speed		1,700 ± 100 rpm	
Recommended antifreeze		Pro Honda HP Coolant or an equivalent high quality ethylene glycol antifreeze containing silicate-free corrosion inhibitors	
Drive belt width	'13 model	Service limit: 21.0 mm (0.83 in)	
	After '13 model	Service limit: 21.6 mm (0.85 in)	
Recommended final reduction oil		Pro Honda HP4M 4-stroke oil (U.S.A. and Canada) or equivalent motor oil API service classification: SJ or higher JASO T 903 standard: MB Viscosity: SAE 10W-30	
Final reduction oil capacity	After draining	0.12 liter (0.13 US qt, 0.11 Imp qt)	
	After disassembly	0.14 liter (0.15 US qt, 0.12 Imp qt)	
Rear brake lever freeplay		10 – 20 mm (0.4 – 0.8 in)	
Clutch lining thickness		Service limit: 2.0 mm (0.08 in)	
Cold tire pressure	Up to 90 kg (200 lbs) load	Front	200 kPa (2.00 kgf/cm <sup>2</sup> , 29 psi)
		Rear	225 kPa (2.25 kgf/cm <sup>2</sup> , 33 psi)
	Up to maximum weight capacity	Front	200 kPa (2.00 kgf/cm <sup>2</sup> , 29 psi)
		Rear	250 kPa (2.50 kgf/cm <sup>2</sup> , 36 psi)
Tire size	Front	90/90-14M/C 46P	
	Rear	100/90-14M/C 57P	
Tire brand ('13 model)	IRC	Front	SS-560F
		Rear	SS-560R
	DUNLOP	Front	TT900F
		Rear	TT900A
Tire brand (After '13 model)	IRC	Front	SS-560F
		Rear	SS-560R $\phi$
Minimum tire tread depth	Front	1.5 mm (0.06 in)	
	Rear	2.0 mm (0.08 in)	



**TORQUE VALUES**

ITEM	Q'TY	THREAD DIA. (mm)	TORQUE N·m (kgf·m, lbf·ft)	REMARKS
Spark plug	1	10	16 (1.6, 12)	
Valve adjusting screw lock nut	2	5	10 (1.0, 7)	Apply oil to the threads and seating surface.
Engine oil drain bolt	1	12	24 (2.4, 18)	
Engine oil strainer screen cap	1	30	20 (2.0, 15)	
Final reduction oil check bolt	1	8	23 (2.3, 17)	
Final reduction oil drain bolt	1	8	23 (2.3, 17)	
Air cleaner housing cover screw	7	5	1.1 (0.11, 0.8)	
1st rear brake cable lock nut	1	8	6.5 (0.66, 4.8)	
Brake lock cable lock nut	2	6	3 (0.31, 2.2)	

**TOOL**

Valve adjusting wrench  
07908-KE90000

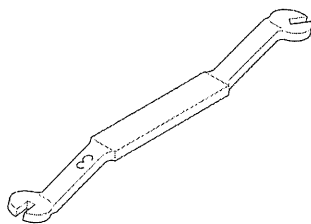

or Tappet wrench, 3 mm  
07908-KE90200 (U.S.A. only)

## MAINTENANCE

# MAINTENANCE SCHEDULE ('13 MODEL)

Perform the Pre-ride inspection in the Owner's Manual at each scheduled maintenance period.

I: Inspect and Clean, Adjust, Lubricate or Replace if necessary. C: Clean. R: Replace. A: Adjust. L: Lubricate.

The following items require some mechanical knowledge. Certain items (particularly those marked \* and \*\*) may require more technical information and tools. Consult a dealer.

ITEMS	FREQUENCY	NOTE	ODOMETER READING (NOTE 1)				REFER TO PAGE	
			X1,000 km	1	4	8		12
			X1,000 mi	0.6	2.5	5		7.5
EMISSION RELATED ITEMS	* FUEL LINE						3-6	
	* THROTTLE OPERATION						3-6	
	AIR CLEANER	NOTE2		EVERY 10,000 mi (16,000 km) R			3-7	
	CRANKCASE BREATHER	NOTE3		C	C	C	3-8	
	SPARK PLUG				R		3-9	
	* VALVE CLEARANCE						3-10	
	ENGINE OIL			INITIAL= 600 mi (1,000 km) or 1 month: R REGULAR= EVERY 5,000 mi (8,000 km) or 12 months: R			3-11	
	* ENGINE OIL STRAINER SCREEN					C	3-12	
	* ENGINE IDLE SPEED						3-13	
	RADIATOR COOLANT	NOTE4					3-13	
	* COOLING SYSTEM						3-14	
* EVAPORATIVE EMISSION CONTROL SYSTEM							3-15	
NON-EMISSION RELATED ITEMS	* DRIVE BELT			EVERY 5,000 mi (8,000 km) I, EVERY 15,000 mi (24,000 km) R			3-15	
	* FINAL DRIVE OIL	NOTE4					3-16	
	BRAKE FLUID	NOTE4					3-17	
	BRAKE SHOES/PADS WEAR						3-17	
	BRAKE SYSTEM						3-18	
	BRAKE LIGHT SWITCH						3-20	
	* BRAKE LOCK OPERATION						3-21	
	HEADLIGHT AIM						3-22	
	** CLUTCH SHOES WEAR						3-23	
	SIDESTAND						3-23	
	* SUSPENSION						3-23	
	* NUTS, BOLTS, FASTENERS						3-24	
	** WHEELS/TIRES						3-24	
** STEERING HEAD BEARINGS						3-25		

\* Should be serviced by a dealer, unless the owner has proper tools and service data and is mechanically qualified.

\*\* In the interest of safety, we recommend these items be serviced only by a dealer.

Honda recommends that a dealer should road test your scooter after each periodic maintenance is carried out.

### NOTES:

1. At higher odometer readings, repeat at the frequency interval established here.
2. Service more frequently when riding in unusually wet or dusty areas.
3. Service more frequently when riding in rain or at full throttle.
4. Replace every 2 years. Replacement requires mechanical skill.

# MAINTENANCE SCHEDULE (AFTER '13 MODEL)

Perform the Pre-ride inspection in the Owner's Manual at each scheduled maintenance period.

I: Inspect and Clean, Adjust, Lubricate or Replace if necessary. C: Clean. R: Replace. A: Adjust. L: Lubricate.

The following items require some mechanical knowledge. Certain items (particularly those marked \* and \*\*) may require more technical information and tools. Consult a dealer.

ITEMS	NOTE	FREQUENCY (NOTE 1)									REFER TO PAGE	
		X1,000 mi	0.6	2.5	5	7.5	10	12.5	15			
		X1,000 km	1	4	8	12	16	20	24			
EMISSION RELATED ITEMS	* FUEL LINE			I	I	I	I	I	I		3-6	
	* THROTTLE OPERATION			I	I	I	I	I	I		3-6	
	AIR CLEANER	NOTE2						R			3-7	
	CRANKCASE BREATHER	NOTE3			C	C	C	C	C	C	3-8	
	SPARK PLUG					R		R		R	3-9	
	* VALVE CLEARANCE			I	I	I	I	I	I	I	3-10	
	ENGINE OIL		INITIAL= 600 mi (1,000 km) or 1 month: R REGULAR= EVERY 5,000 mi (8,000 km) or 12 months: R									3-11
	ENGINE OIL STRAINER SCREEN					C		C		C	3-12	
	* ENGINE IDLE SPEED			I	I	I	I	I	I	I	3-13	
	RADIATOR COOLANT	NOTE5				I		I		I	3-13	
* COOLING SYSTEM					I		I		I	3-14		
* EVAPORATIVE EMISSION CONTROL SYSTEM	NOTE4					I			I	3-15		
NON-EMISSION RELATED ITEMS	* DRIVE BELT				I		I			R	3-15	
	* FINAL DRIVE OIL	NOTE5									3-16	
	BRAKE FLUID	NOTE5			I	I	I	I	I	I	3-17	
	BRAKE SHOES/PADS WEAR				I	I	I	I	I	I	3-17	
	BRAKE SYSTEM			I	I	I	I	I	I	I	3-18	
	* BRAKE LOCK OPERATION			I	I	I	I	I	I	I	3-21	
	HEADLIGHT AIM				I	I	I	I	I	I	3-22	
	** CLUTCH SHOES WEAR						I			I	3-23	
	SIDESTAND				I	I	I	I	I	I	3-23	
	* SUSPENSION				I	I	I	I	I	I	3-23	
* NUTS, BOLTS, FASTENERS			I		I		I		I	3-24		
** WHEELS/TIRES				I	I	I	I	I	I	3-24		
** STEERING HEAD BEARINGS			I			I			I	3-25		

\* Should be serviced by a dealer, unless the owner has proper tools and service data and is mechanically qualified.

\*\* In the interest of safety, we recommend these items be serviced only by a dealer.

**NOTES:**

1. At higher odometer readings, repeat at the frequency interval established here.
2. Service more frequently when riding in unusually wet or dusty areas.
3. Service more frequently when riding in rain or at full throttle.
4. 50 STATE (meets California)
5. Replace every 2 years. Replacement requires mechanical skill.

## MAINTENANCE

### FUEL LINE

Remove the two bolts and pull up the battery box (page 7-6).

Check the fuel hose [1] for deterioration, damage or leakage.

Also, check the fuel hose fittings [2] for leakage.

Replace the fuel hose if necessary.

Install the battery box (page 7-7).

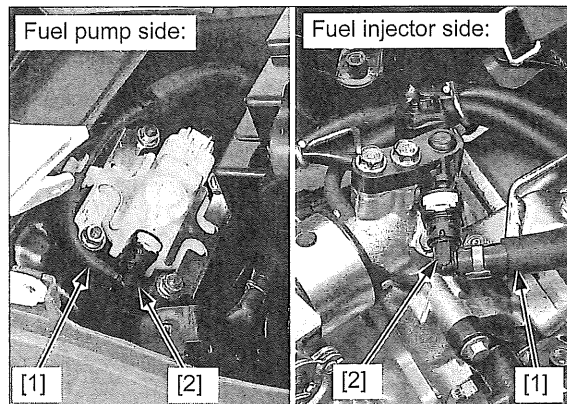

### THROTTLE OPERATION

#### NOTE:

- Reusing a damaged or abnormally bent or kinked throttle cable can prevent proper throttle valve operation and may lead to a loss of throttle control while riding.

Check for any deterioration or damage to the throttle cable. Check the throttle grip for smooth operation. Check that the throttle opens and automatically closes in all steering positions.

If the throttle grip does not return properly, overhaul and lubricate the throttle grip housing.

If the throttle grip still does not return properly, replace the throttle cable.

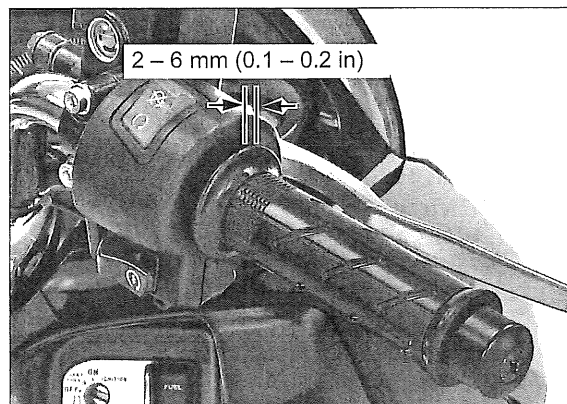

With the engine idling, turn the handlebar all the way to the right and left to ensure that the idle speed does not change. If idle speed increases, check the throttle grip freeplay and throttle cable routing.

Measure the throttle grip freeplay at the throttle grip flange.

**FREEPLAY: 2 - 6 mm (0.1 - 0.2 in)**

*'13 model:* Throttle grip freeplay can be adjusted by turning the adjuster [1].

Loosen the lock nut [2] and turn the adjusting nut as required.

Tighten the lock nut.

Recheck the throttle operation.

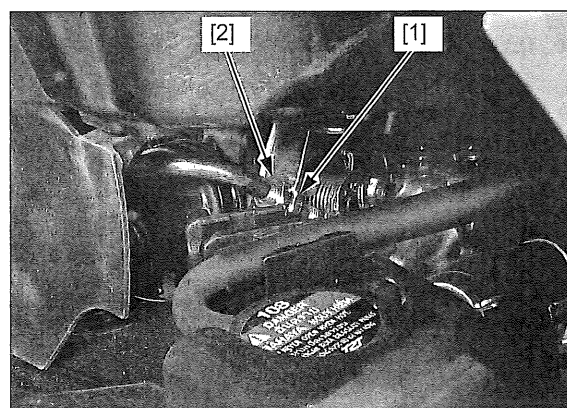

*After '13 model:* Throttle grip freeplay can be adjusted by turning the adjuster [1].

Loosen the lock nut [2] and turn the adjuster as required.

Tighten the lock nut to the specified torque.

**TORQUE: 3.8 N·m (0.39 kgf·m, 2.8 lbf·ft)**

Recheck the throttle operation.

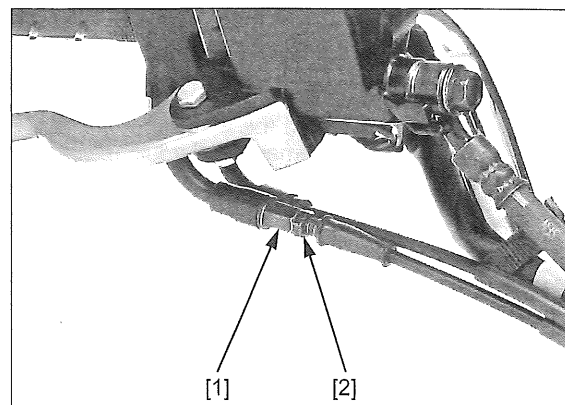

## AIR CLEANER

**NOTE:**

- The viscous paper element cannot be cleaned because the element contains a dust adhesive.
- If the scooter is used in unusually wet or dusty areas, more frequent inspections are required.

*'13 model:* Remove the screws [1] and air cleaner housing cover [2].

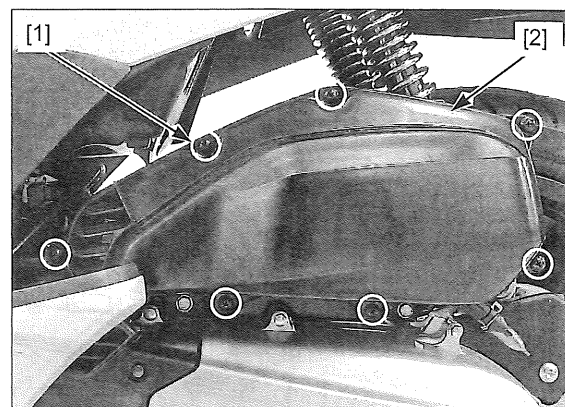

Remove the air cleaner element [1] from the air cleaner housing cover [2].

Discard the air cleaner element in accordance with the maintenance schedule (page 3-4).

Replace the element any time if it is excessively dirty or damaged.

Install the removed parts in the reverse order of removal.

**TORQUE:**

**Air cleaner housing cover screw:**  
**1.1 N·m (0.11 kgf·m, 0.8 lbf·ft)**

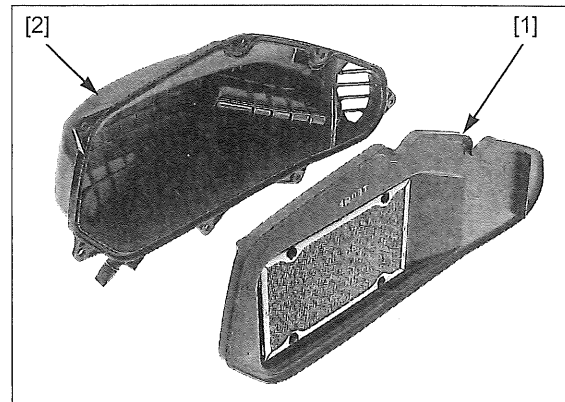

## MAINTENANCE

Remove the screws [1] and air cleaner housing cover [2].

After '13 model: Remove the air cleaner element [3].

Discard the air cleaner element in accordance with the maintenance schedule (page 3-5).

Replace the element any time if it is excessively dirty or damaged.

*Align the locating portions of the air cleaner housing [4] and air cleaner element.*

Install the removed parts in the reverse order of removal.

### TORQUE:

**Air cleaner housing cover screw:**  
**1.1 N·m (0.11 kgf·m, 0.8 lbf·ft)**

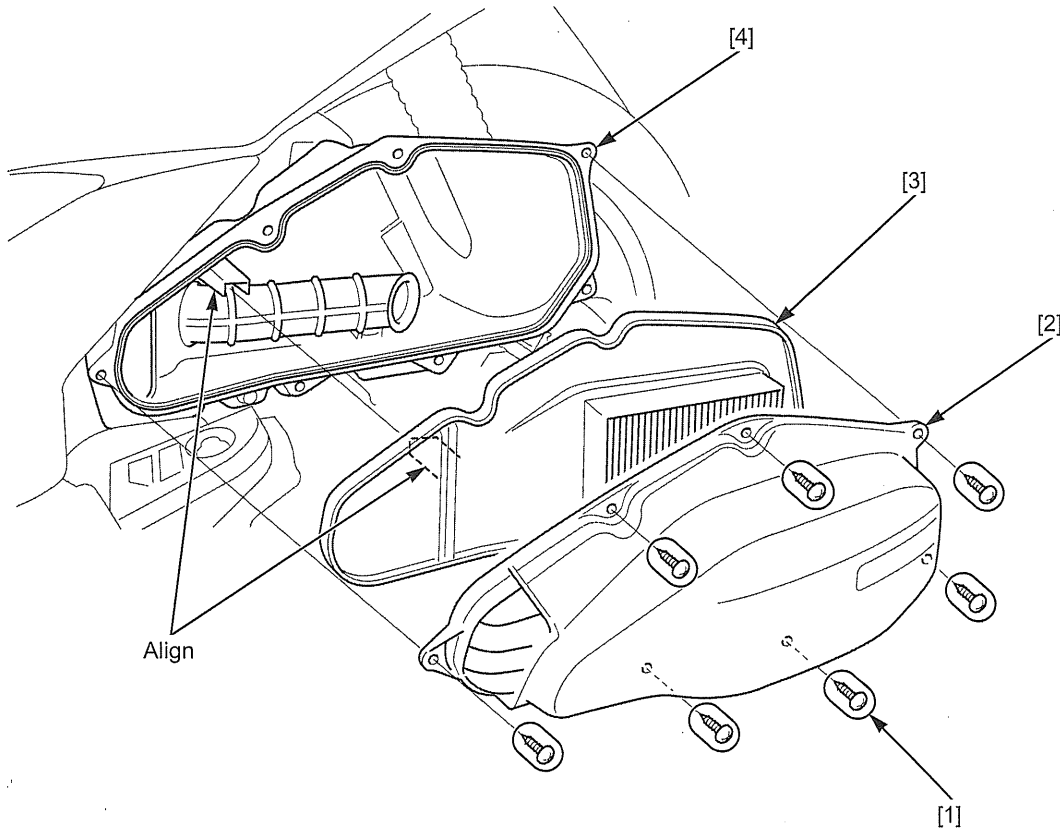

## CRANKCASE BREATHER

### NOTE:

- Service more frequently when ridden in rain, at full throttle, or after the scooter is washed or overturned. Service if the deposit level can be seen in the transparent section of the drain plug.

Remove the crankcase breather drain plug [1] from the air cleaner and drain deposits into a suitable container.

Install the crankcase breather drain plug.

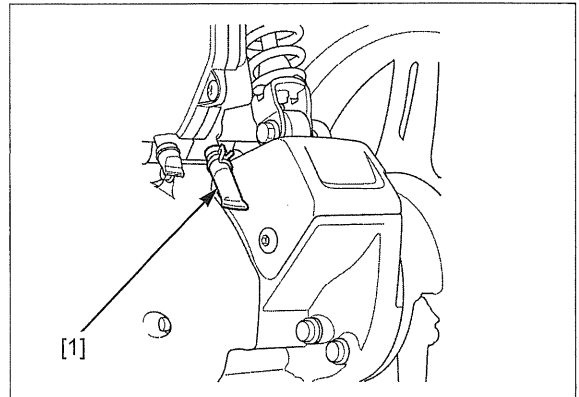

Remove the luggage box (page 2-25).  
 Check the crankcase breather hose [1] for deterioration, damage or leakage.  
 Replace the crankcase breather hose if necessary.  
 Also check the crankcase breather hose fittings for leakage.  
 Install the luggage box (page 2-25).

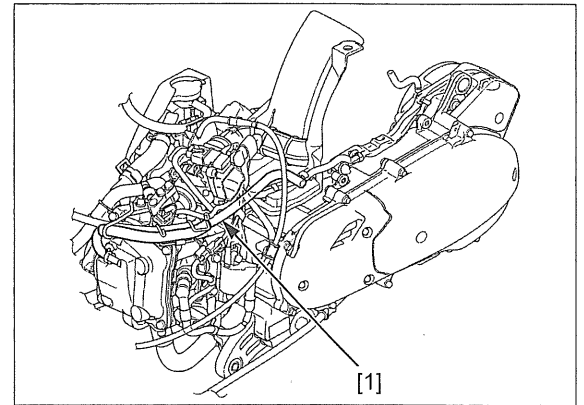

## SPARK PLUG

Support the scooter with its centerstand. Remove the plug maintenance lid (page 2-18).

*Clean around the spark plug base with compressed air before removing the plug and make sure no debris is allowed to enter the combustion chamber.*

Disconnect the spark plug cap [1] and remove the spark plug [2].  
 Inspect or replace as described in the maintenance schedule (page 3-4).

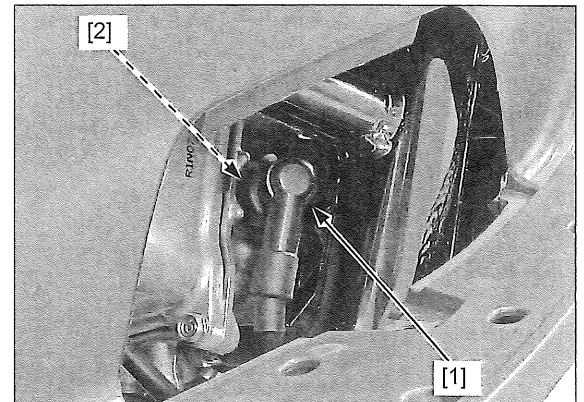

Clean the spark plug electrodes with a wire brush or special plug cleaner.  
 Check the insulator for cracks or damage, and the electrodes for wear, fouling or discoloration.

*Always use the specified spark plug on this motorcycle.*

**SPECIFIED SPARK PLUG: CPR7EA-9 (NGK)**

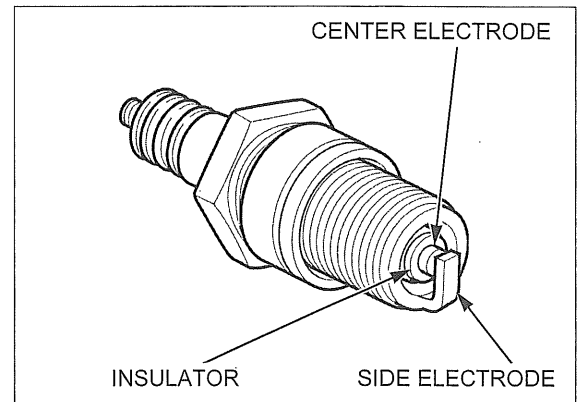

Measure the spark plug gap between the center and side electrodes with a wire type feeler gauge.  
 If necessary, adjust the gap by bending the side electrode carefully.

**SPARK PLUG GAP: 0.8 – 0.9 mm (0.03 – 0.04 in)**

Install and hand tighten the spark plug to the cylinder head, then tighten the spark plug to the specified torque.

**TORQUE: 16 N·m (1.6 kgf·m, 12 lbf·ft)**

Install the removed parts in the reverse order of removal.

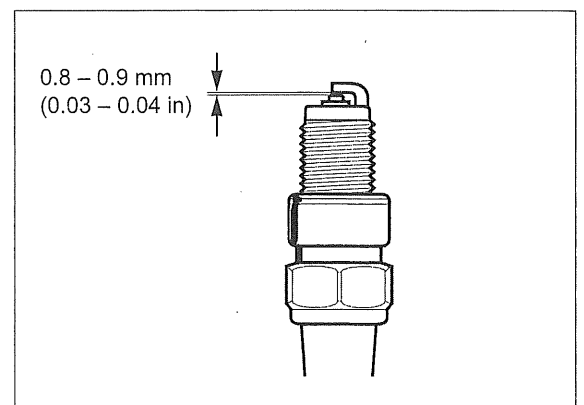

# VALVE CLEARANCE

## INSPECTION

- Inspect and adjust the valve clearance while the engine is cold (below 35°C/95°F).

Remove the following:

- Side cover (page 2-8)
- Radiator cover (page 9-4)
- Cylinder head cover (page 10-6)
- Three bolts [1]
- Left crankcase cover duct [2]

*It is not necessary to disconnect the water hoses from the radiator.*

Remove the four radiator mounting bolts and move the radiator so that the cooling fan is visible (page 9-7).

Rotate the crankshaft [3] counterclockwise slowly and align the cut out ("T" mark) [4] of the cooling fan with the index mark [5] on the crankcase.

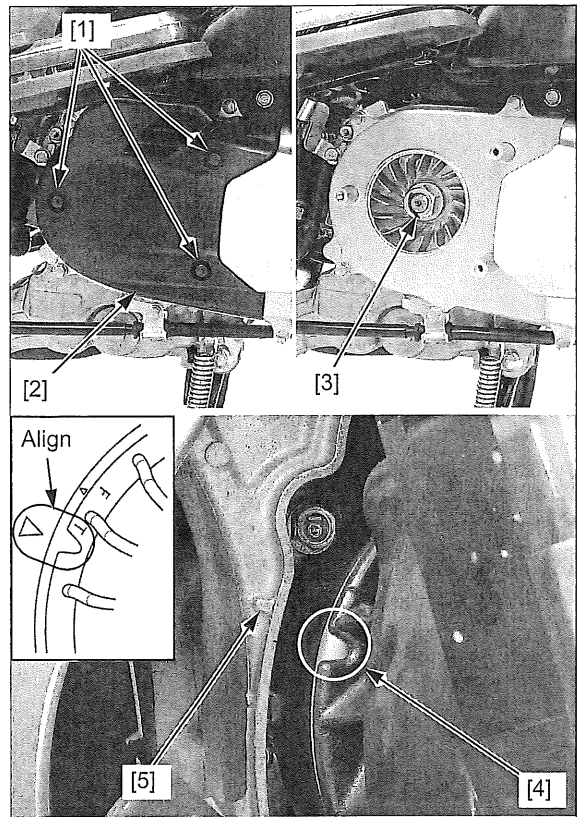

Make sure the mark [1] of the camshaft and index line [2] of the cylinder head are aligned.

Make sure the piston is at TDC (Top Dead Center) on the compression stroke.

This position can be confirmed by checking that there is slack in the rocker arm.

If there is no slack, it is because the piston is moving through the exhaust stroke to TDC.

Rotate the crankshaft one full turn counterclockwise slowly and match up again.

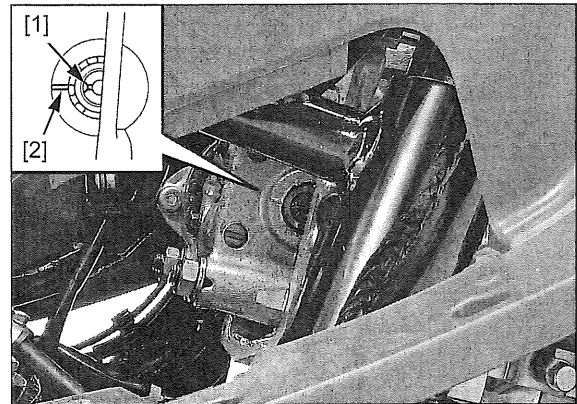

Check the valve clearance by inserting a feeler gauge [1] between the valve adjusting screw and valve stem.

### VALVE CLEARANCE:

**IN:** 0.10 ± 0.02 mm (0.004 ± 0.001 in)

**EX:** 0.24 ± 0.02 mm (0.009 ± 0.001 in)

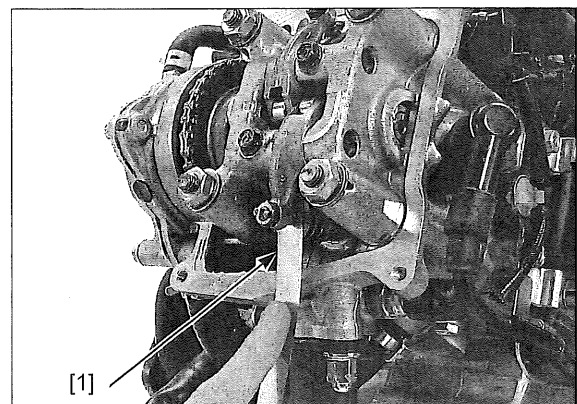



If the valve clearance is incorrect, loosen the valve adjusting screw lock nut [1] and adjust the valve clearance by turning the adjusting screw [2] until there is a slight drag on the feeler gauge [3]. Apply engine oil to the valve adjusting screw lock nut threads and seating surface. Hold the adjusting screw using a special screw and tighten the lock nut to the specified torque.

**TOOL:**

[4] Valve adjusting wrench 07908-KE90000

**U.S.A. tool:**

Tappet wrench, 3 mm 07908-KE90200

**TORQUE: 10 N·m (1.0 kgf·m, 7 lbf·ft)**

Recheck the valve clearance.

Make sure the left crankcase cover duct rubber seal [1] is in good condition and replace it if necessary.

Install the left crankcase cover duct by aligning the holes with bosses of the left crankcase cover.

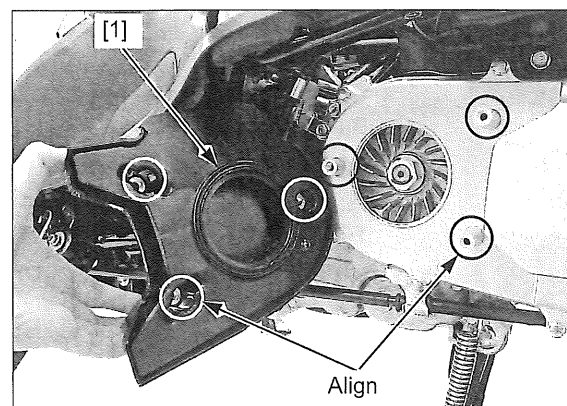
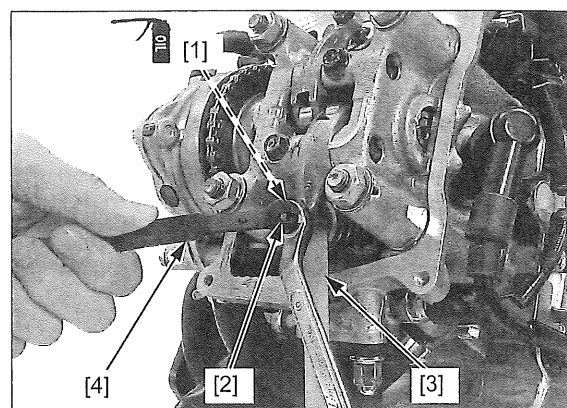

Install and tighten the three bolts [1].

Install the following:

- Cylinder head cover (page 10-7)
- Four radiator mounting bolts (page 9-7)
- Radiator cover (page 9-4)
- Side cover (page 2-8)

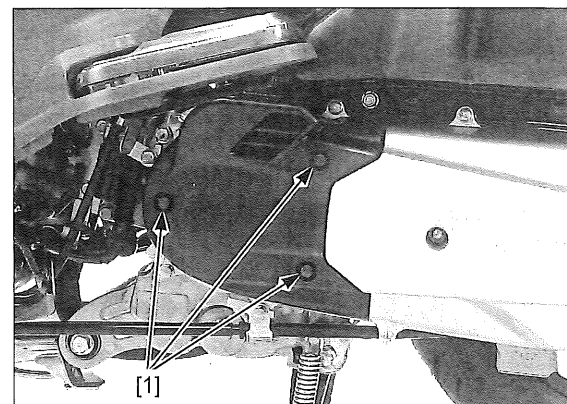

## ENGINE OIL

### OIL LEVEL CHECK

Support the scooter with its centerstand on a level surface.

Start the engine and let it idle for 3 - 5 minutes. Stop the engine and wait for 2 - 3 minutes.

Remove the oil filler cap/dipstick [1] and wipe off the oil from the dipstick with a clean cloth.

Insert the oil filler cap/dipstick without screwing it in, remove it and check the oil level.

The level should be between the "UPPER" and "LOWER" level lines of the oil filler cap/dipstick.

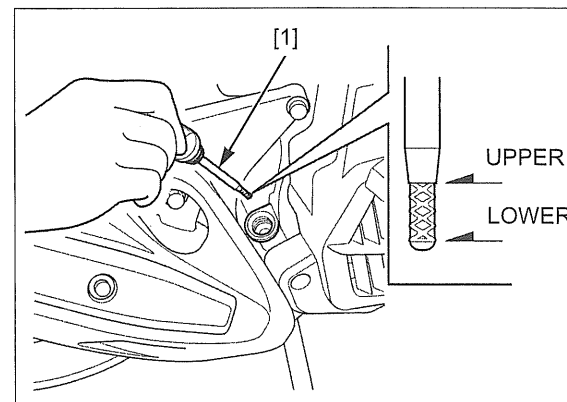

## MAINTENANCE

Other viscosities shown in the chart may be used when the average temperature in your riding area is within the indicated range.

If the oil level is below or near the lower level line on the dipstick, add the recommended oil to the upper level.

### RECOMMENDED ENGINE OIL:

**Pro Honda HP4M 4-stroke oil (U.S.A. and Canada) or equivalent motor oil**

**API service classification: SJ or higher**

**JASO T 903 standard: MB**

**Viscosity: SAE 10W-30**

Install the oil filler cap/dipstick.

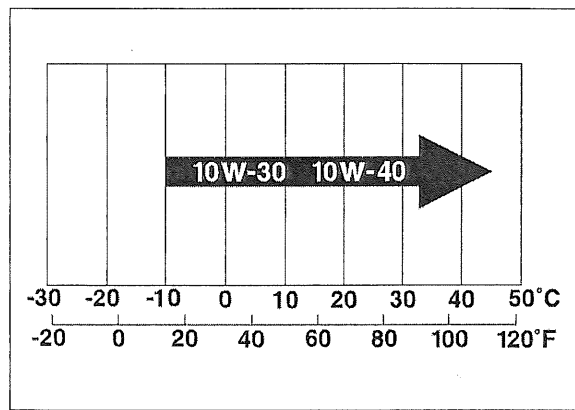

## OIL CHANGE

Warm up the engine.

Stop the engine and remove the oil filler cap/dipstick (page 3-11).

Remove the drain bolt [1] and sealing washer [2]. Drain oil completely.

Install the oil drain bolt with a new sealing washer and tighten it to the specified torque.

**TORQUE: 24 N·m (2.4 kgf·m, 18 lbf·ft)**

Fill the crankcase with the recommended engine oil (page 3-12).

### ENGINE OIL CAPACITY:

**0.8 liter (0.8 US qt, 0.7 Imp qt) after draining**

**0.9 liter (1.0 US qt, 0.8 Imp qt) after disassembly**

**0.9 liter (1.0 US qt, 0.8 Imp qt) after oil strainer removal**

Check that the O-ring on the oil filler cap is in good condition, and replace it if necessary.

Install the oil filler cap/dipstick and check the oil level (page 3-11).

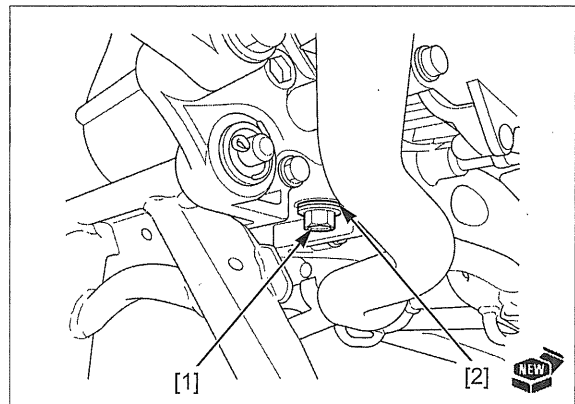

## ENGINE OIL STRAINER SCREEN

Drain the engine oil (page 3-12).

Remove the oil strainer screen cap [1], O-ring [2], spring [3] and oil strainer screen [4].

Wash the strainer screen thoroughly in non-flammable or high flash point cleaning solvent until all accumulated dirt has been removed.

Blow dry it with compressed air to clean completely.

Before installing the strainer screen, it should be examined closely for damage and make sure the sealing rubber is in good condition.

Make sure the O-ring is in good condition and replace it if necessary.

Install the oil strainer screen and spring with the strainer sealing rubber toward the crankcase.

Coat the O-ring with engine oil and install the oil strainer screen cap.

Tighten the oil strainer screen cap to the specified torque.

**TORQUE: 20 N·m (2.0 kgf·m, 15 lbf·ft)**

Fill the crankcase with recommended engine oil and check the engine oil level (page 3-11).

Make sure that there are no oil leaks.

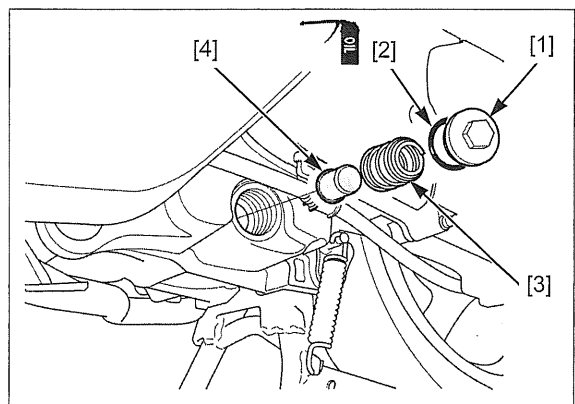

## ENGINE IDLE SPEED

- Inspect the idle speed after all other engine maintenance items have been performed and are within specifications.
- Before checking the idle speed, inspect following items.
  - No MIL blinking
  - Spark plug condition (page 3-9)
  - Air cleaner condition (page 3-7)
- The engine must be warm for accurate idle speed inspection.
- This system eliminates the need for manual idle speed adjustment.
- Use a tachometer with graduations of 50 rpm or smaller that will accurately indicate a 50 rpm change.

Support the scooter with its centerstand.

Warm up the engine about ten minutes.

Connect the tachometer and check the idle speed.

**ENGINE IDLE SPEED: 1,700 ± 100 rpm**

If the idle speed is out of the specification, check the following:

- Throttle operation and throttle grip freeplay (page 3-6).
- Intake air leak or engine top-end problem (page 10-5).
- IACV operation (page 7-23).

## RADIATOR COOLANT

*'13 model:* Support the scooter with its centerstand.

Unlock and open the seat.

Check the coolant level of the reserve tank with the engine running at normal operating temperature. The level should be between the "UPPER" level line [1] and "LOWER" level line [2] with the scooter upright on a level surface.

If the level is low, fill as follows:

Remove the radiator reserve tank lid (page 9-6). Remove the reserve tank cap [3] and fill the tank to the "UPPER" level line with a 1:1 mixture of distilled water and antifreeze.

### RECOMMENDED ANTIFREEZE:

**Pro Honda HP Coolant or an equivalent high quality ethylene glycol antifreeze containing silicate-free corrosion inhibitors**

Check if there are any coolant leaks when the coolant level decreases very rapidly.

If the reserve tank becomes completely empty, there is a possibility of air getting into the cooling system.

Be sure to remove all air from the cooling system (page 9-5).

Install the radiator reserve tank lid (page 9-6).

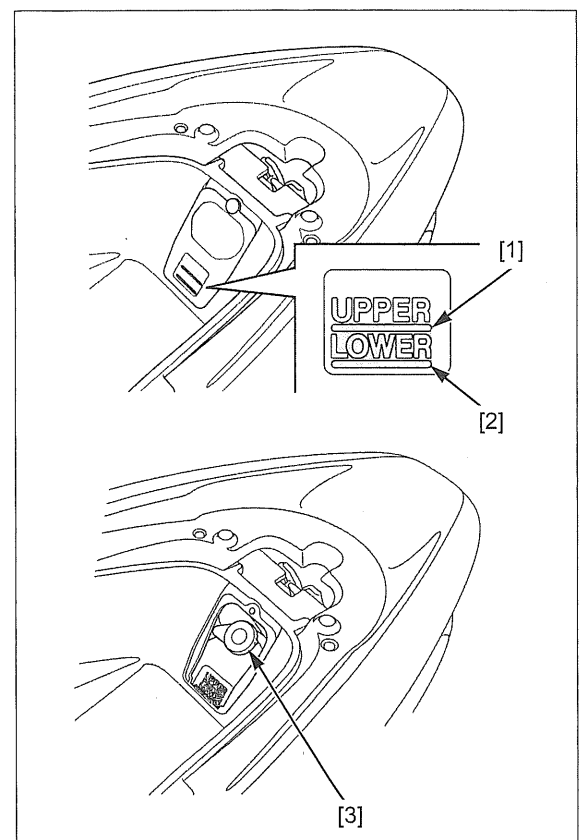

## MAINTENANCE

After '13 model: Support the scooter with its centerstand.

Check the coolant level of the reserve tank with the engine running at normal operating temperature. The level should be between the "UPPER" level line and "LOWER" level line with the scooter upright on a level surface.

If the level is low, fill as follows:

Remove the radiator reserve tank lid [1].  
Remove the reserve tank cap [2] and fill the tank to the "UPPER" level line with a recommend antifreeze.

### RECOMMENDED ANTIFREEZE:

**High quality ethylene glycol antifreeze containing silicate-free corrosion inhibitors**

Check if there are any coolant leaks when the coolant level decreases very rapidly.

If the reserve tank becomes completely empty, there is a possibility of air getting into the cooling system.

Be sure to remove all air from the cooling system (page 9-5).

Install the radiator reserve tank lid.

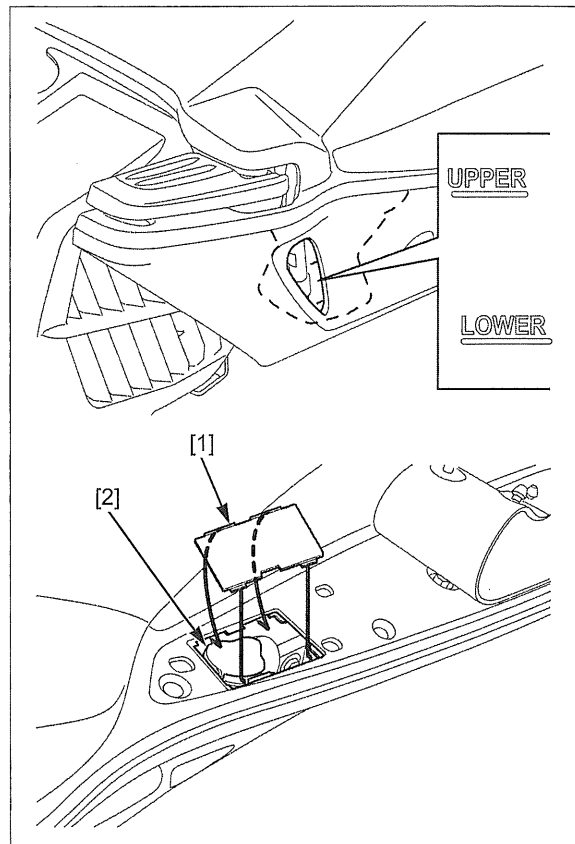

## COOLING SYSTEM

Remove the following:

- Luggage box (page 2-25)
- Radiator cover (page 9-4)

Check the radiator [1] for leakage.  
Check for coolant leakage from the water pump [2], water hoses [3] and hose joints [4].  
Check the water hoses for cracks or deterioration and replace if necessary.  
Check that all hose clamps are tight.

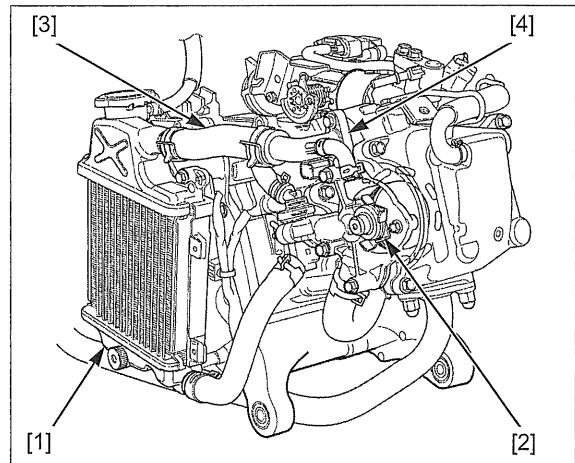

Check the radiator air passage for clogs or damage. Straighten bent fins with a small, flat blade screwdriver and remove insects, mud or other obstructions with compressed air or low pressure water. Replace the radiator if the air flow is restricted over more than 20% of the radiating surface.

Install the removed parts in the reverse order of removal.

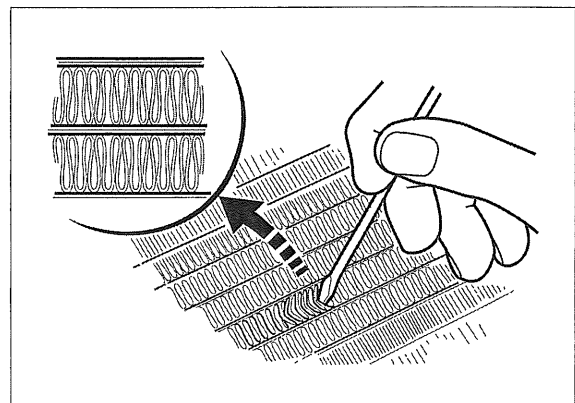

## EVAPORATIVE EMISSION CONTROL SYSTEM (EXCEPT AFTER '13 MODEL CM TYPE)

Remove the floor step (page 2-19).

Check the hoses between the fuel tank, EVAP canister [1], EVAP purge control solenoid valve [2], and intake pipe for deterioration, damage or loose connection.

Check the EVAP canister for cracks or other damage.

Install the floor step (page 2-19).

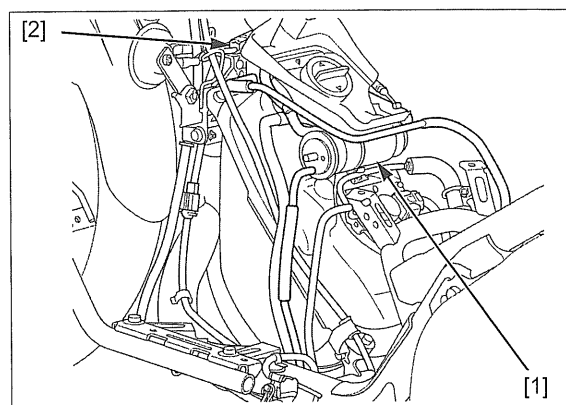

## DRIVE BELT

Remove the left crankcase cover (page 12-6).

Check the drive belt [1] for cracks, separation or abnormal or excessive wear and replace it if necessary (page 12-8).

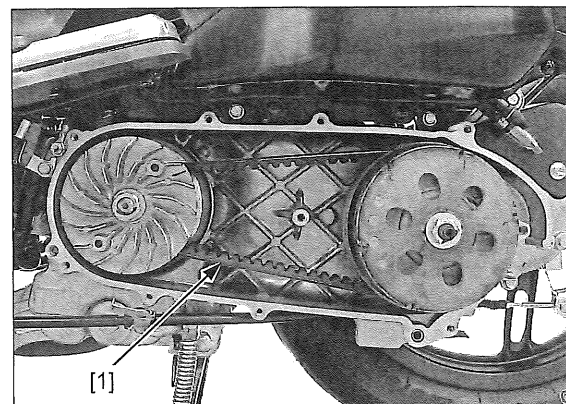

Using the suitable two flat plates, measure the drive belt [1] width as shown.

### SERVICE LIMITS:

'13 model: 21.0 mm (0.83 in)

After '13 model: 21.6 mm (0.85 in)

Replace the drive belt if it is less than the service limit (page 12-8).

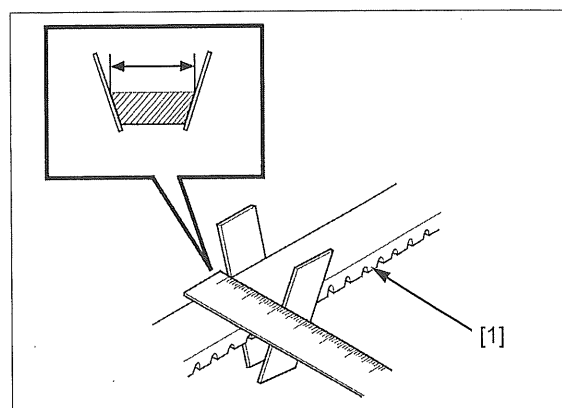

## FINAL DRIVE OIL

### OIL LEVEL CHECK

Make sure that the final reduction case has no oil leaks.

Support the scooter with its centerstand.

Remove the oil check bolt [1] and sealing washer [2].

Check whether the oil flows out from the check bolt hole.

If the level is low (oil does not flow out), add the recommended oil as described below.

#### RECOMMENDED ENGINE OIL:

**Pro Honda HP4M 4-stroke oil (U.S.A. and Canada)  
or equivalent motor oil**

**API service classification: SJ or higher**

**JASO T 903 standard: MB**

**Viscosity: SAE 10W-30**

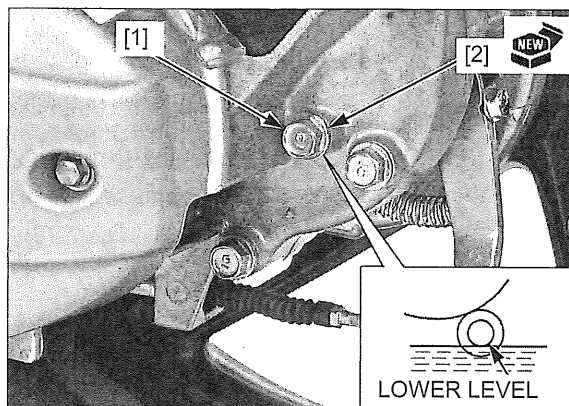

Install the oil check bolt with a new sealing washer and tighten it to the specified torque.

**TORQUE: 23 N·m (2.3 kgf·m, 17 lbf·ft)**

### OIL CHANGE

Place an oil drain pan under the final reduction case to collect the oil, then remove the oil check bolt [1], oil drain bolt [2] and sealing washers [3].

Slowly turn the rear wheel and drain the oil.

After draining the oil completely, install the oil drain bolt with a new sealing washer and tighten the drain bolt to the specified torque.

**TORQUE: 23 N·m (2.3 kgf·m, 17 lbf·ft)**

Fill the final reduction case with recommended oil up to the correct level (page 3-16).

#### FINAL REDUCTION OIL CAPACITY:

**0.12 liter (0.13 US qt, 0.11 Imp qt) after draining**

**0.14 liter (0.15 US qt, 0.12 Imp qt) after  
disassembly**

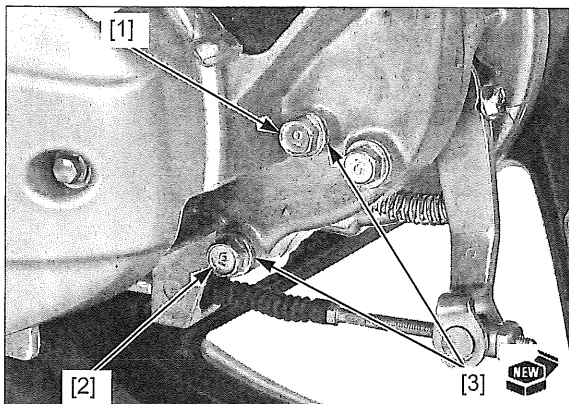

Install the oil check bolt with a new sealing washer and tighten it to the specified torque.

**TORQUE: 23 N·m (2.3 kgf·m, 17 lbf·ft)**

## BRAKE FLUID

- Spilled brake fluid can damage painted, plastic or rubber parts. Place a rag over these parts whenever the system is serviced.
- Do not mix different types of fluid, as they are not compatible with each other.
- Do not allow foreign material to enter the system when filling the reservoir.
- When the fluid level is low, check the brake pads for wear (page 3-17). A low fluid level may be due to wear of the brake pads.  
If the brake pads are worn, the caliper piston is pushed out, and this accounts for a low reservoir level. If the brake pads are not worn and fluid level is low, check entire system for leaks (page 3-18).

### FRONT BRAKE LINE

Support the scooter with its centerstand. Turn the handlebar to the left so the reservoir is level and check the front brake reservoir fluid level through the sight glass.

If the level is near the "LOWER" level mark [1], check the brake pads for wear (page 3-17).

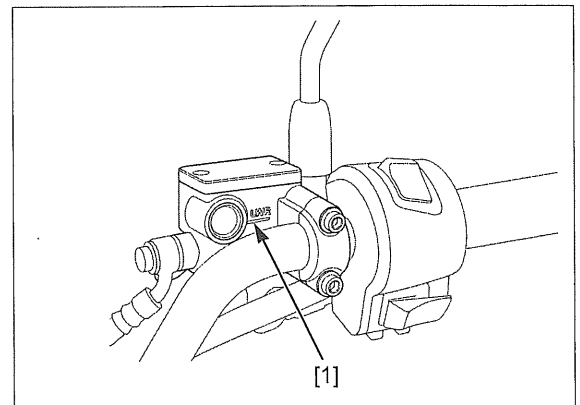

### CBS BRAKE LINE

Support the scooter with its centerstand. Check the CBS brake reservoir fluid level.

If the level is near the "LOWER" level mark [1], check the brake pads for wear (page 3-17).

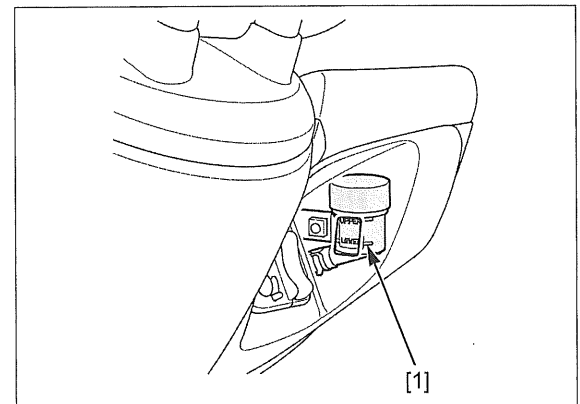

## BRAKE SHOES/PADS WEAR

### FRONT DISC BRAKE PADS

Check the brake pads for wear. Replace the brake pads if either pad is worn to the wear limit groove [1].

For brake pad replacement (page 19-10).

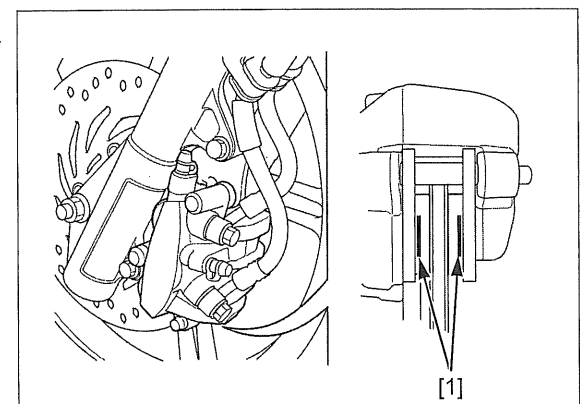

## MAINTENANCE

### REAR DRUM BRAKE SHOES

Check the wear indicator position when the brake lever is applied.

If the indicator [1] aligns with the triangle mark [2], inspect the brake drum (page 18-8).

Replace the brake shoes if the drum I.D. is within service limit.

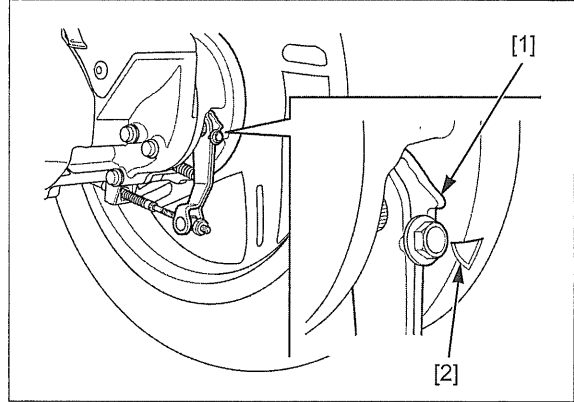

## BRAKE SYSTEM

### FRONT DISC BRAKE

Firmly apply the brake lever and check that no air has entered the system.

If the lever feels soft or spongy when operated, bleed the air from the system.

For air bleeding procedures (page 19-7).

Remove the front meter panel (page 2-7).

Inspect the brake hoses [1] and fittings for deterioration, cracks, or signs of leakage.

Tighten any loose fittings.

Replace the hoses and fittings as required.

Install the front meter panel (page 2-7).

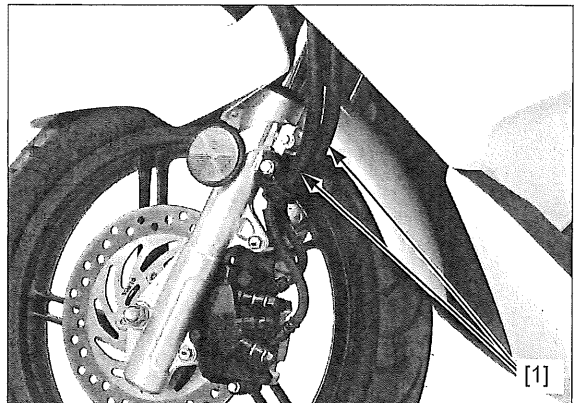

### REAR DRUM BRAKE

Check the brake cable and brake lever for loose connections, excessive play or other damage. Replace or repair if necessary.

Measure the rear brake lever freeplay at the end of the lever.

**FREEPLAY: 10 – 20 mm (0.4 – 0.8 in)**

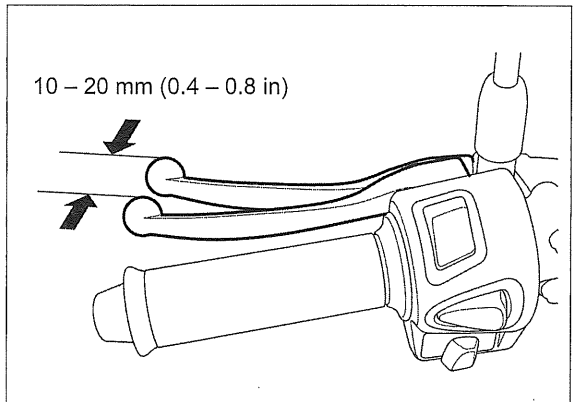



Make sure the cut-out of the adjusting nut is seated on the joint pin.

Adjust the rear brake lever freeplay by turning the rear brake arm adjusting nut [1].

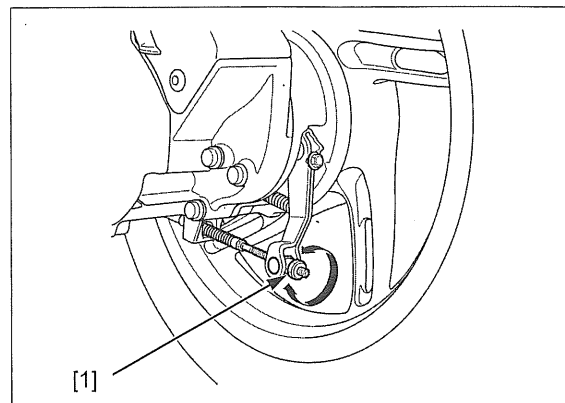

**CBS**

- Before inspection, check the following first:
  - Rear brake system (page 3-18)
  - Front brake system (page 3-18)

Support the scooter with its centerstand.

Apply the rear brake lever. Make sure that the rear wheel does not rotate while the rear brake lever is applied.

Lift the front wheel off the ground and rotate it by hand. Make sure that the front wheel rotates smoothly.

Lift the front wheel off the ground and strongly apply the rear brake lever. Make sure that the front wheel does not rotate while the rear brake lever is applied.

If it is abnormal, inspect as follows:

- Inspect and adjust the CBS with the steering positioned straight.
- Adjust the CBS after removing the CBS master cylinder and/or rear brake cable.

Remove the front meter panel (page 2-7).

Measure the distance between the equalizer [1] and boss [2] of the master cylinder body as shown.

**STANDARD:**

- '13 model: 2 – 3 mm (0.08 – 0.12 in)
- After '13 model: 3 – 4 mm (0.12 – 0.16 in)

If the distance exceeds the standard, adjust the following:

Loosen the rear brake arm adjusting nut [1] fully. Remove the return spring [2].

Push the brake arm and tighten the rear brake adjusting nut until there is no gap between the nut and joint pin [3].

- The rear brake starts being applied at this position.

Install the return spring.

- The brake arm will be pushed back when the return spring is installed, creating the clearance between the brake shoes and brake drum.

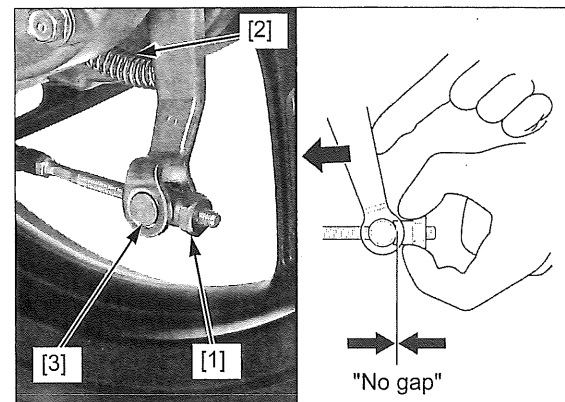
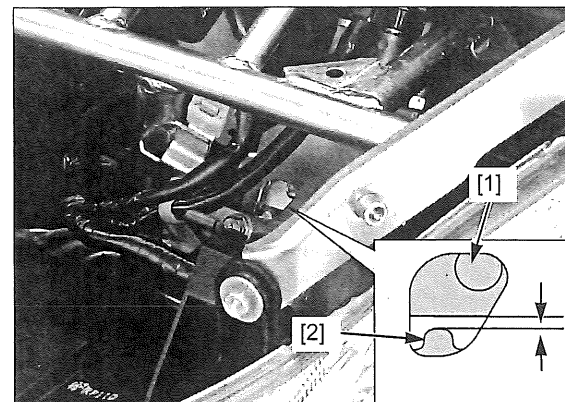

## MAINTENANCE

Loosen the lock nut [1] and turn the adjuster [2] until there is no gap between the edge surface of the rear brake lever and edge surface of the rear brake lever bracket.

Tighten the lock nut while holding the adjuster.

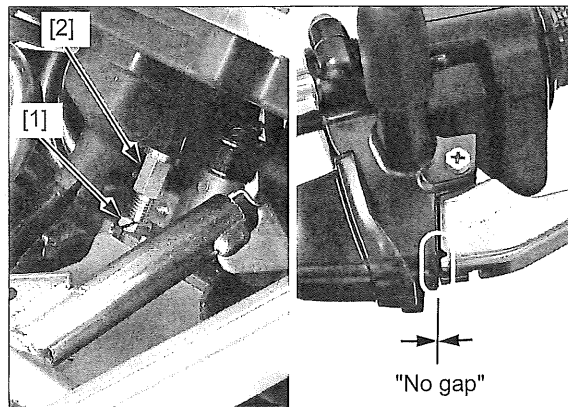

Apply the rear brake lever completely several times.

Recheck the distance between the equalizer [1] and boss [2] of the master cylinder body.

### STANDARD:

'13 model: 2 – 3 mm (0.08 – 0.12 in)

After '13 model: 3 – 4 mm (0.12 – 0.16 in)

- If the combined brake system adjustment is normal, but the front wheel rotates abnormally, check for other malfunction parts.

Install the front meter panel (page 2-7).

Adjust the rear brake lever freeplay (page 3-18).

Check that the rear wheel turns freely without brake dragging.

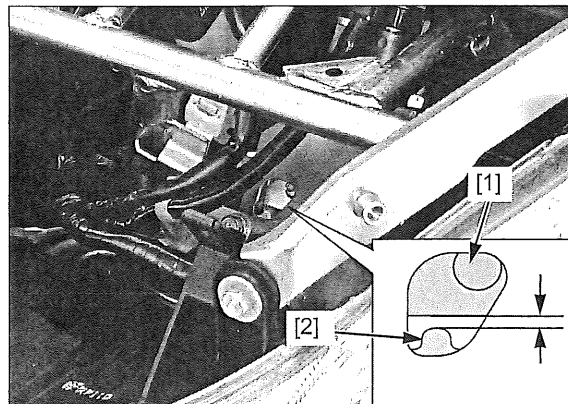

## BRAKE LIGHT SWITCH

### NOTE:

- The brake light switch on the brake lever cannot be adjusted. If the brake light switch actuation and brake engagement are not synchronized, either replace the switch or malfunction parts of the system.

Check that the brake light comes on just prior to the brake actually being engaged.

For brake light switch inspection (page 21-25).

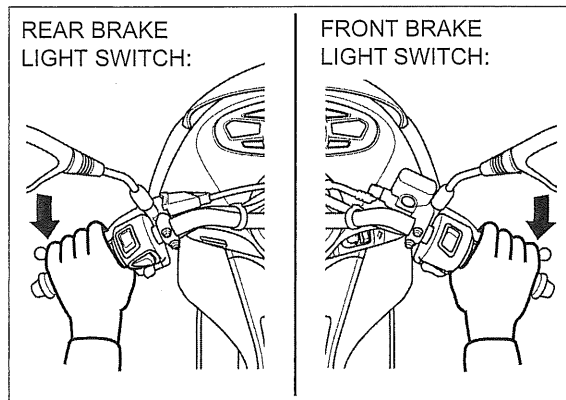

## BRAKE LOCK OPERATION

### INSPECTION

- Before inspection, check the rear brake system (page 3-18).

Squeeze the rear brake lever and pull the brake lock knob [1].

Release the rear brake lever and brake lock knob. Check that the brake lock knob is in the locked position [2] and the rear wheel is locked completely.

Squeeze and hold the rear brake lever.

Press the brake lock knob while pushing in the center button [3], check that the brake lock knob is in the released position [4] and the rear brake is fully released so there is no drag on the rear wheel.

If there is an abnormality in the above inspection, inspect the following:

To apply the brake lock:

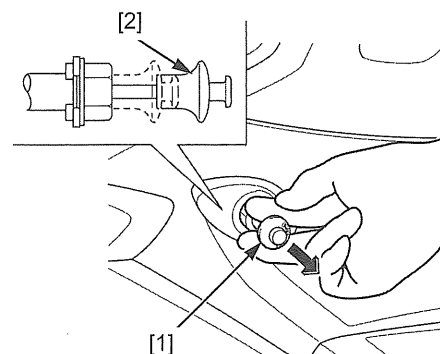

To release the brake lock:

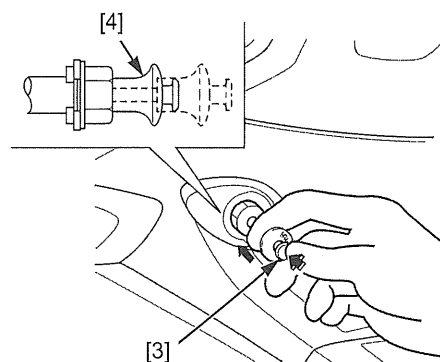

## MAINTENANCE

Remove the front meter panel (page 2-7).

Measure the distance between the brake lock lever [1] and brake lock stay [2] as shown.

**STANDARD: 2.0 – 3.0 mm (0.08 – 0.12 in)**

If the distance exceeds the standard, adjust the following:

Loosen the lock nuts [3] and turn the adjuster [4] until the distance between the edge surface of the brake lock lever and brake lock stay is within standard.

**STANDARD: 2.0 – 3.0 mm (0.08 – 0.12 in)**

Tighten the lock nuts to the specified torque while holding the adjuster.

**TORQUE: 3 N·m (0.31 kgf·m, 2.2 lbf·ft)**

Apply and release the brake lock, then recheck the distance between the brake lock lever and brake lock stay.

**STANDARD: 2.0 – 3.0 mm (0.08 – 0.12 in)**

If the brake lock system adjustment is normal, but the rear wheel is not locked completely, check for other malfunctioning parts.

Install the front meter panel (page 2-7).

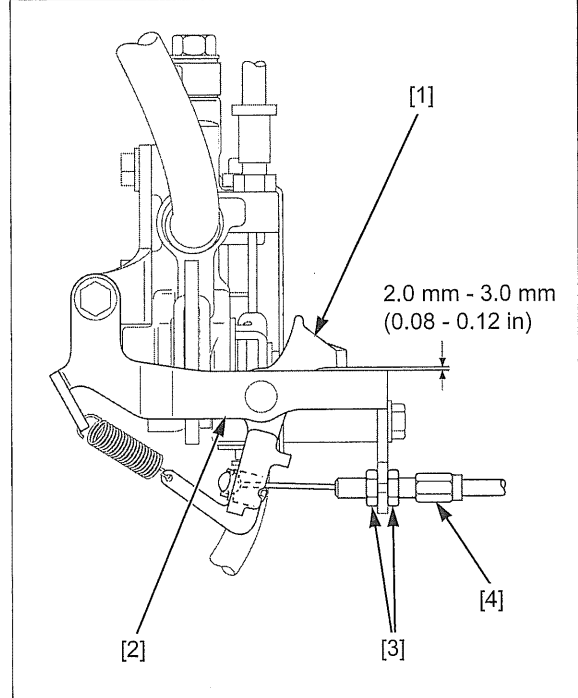
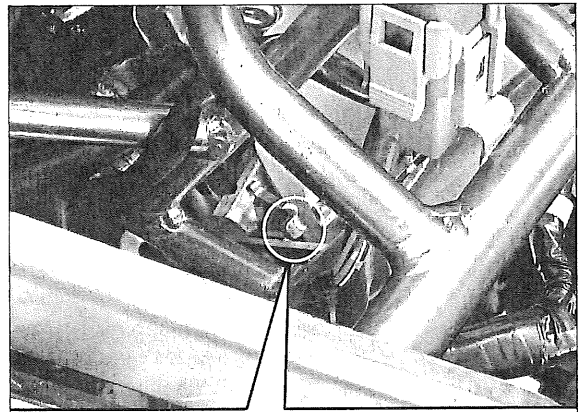

## HEADLIGHT AIM

### NOTE:

- Adjust the headlight beam as specified by local laws and regulations.

Place the scooter on a level ground.

Adjust the headlight beam vertically by turning the headlight aim adjusting screw [1] using the screwdriver.

A clockwise rotation moves the beam up and counterclockwise rotation moves the beam down.

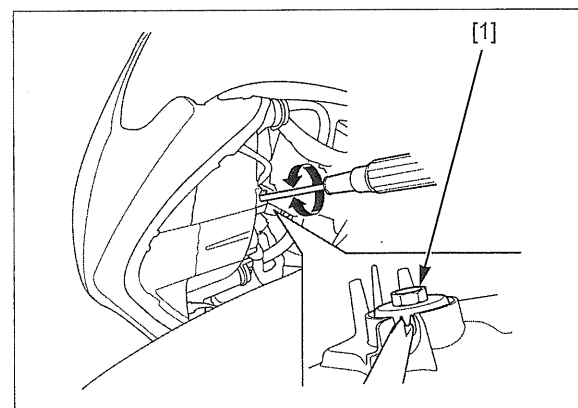

## CLUTCH SHOES WEAR

Remove the clutch outer (page 12-12).

Check the clutch shoes [1] for abnormal wear.  
Measure the thickness of each shoe.

**SERVICE LIMIT: 2.0 mm (0.08 in)**

Replace the clutch shoes if they are less than the service limit (page 12-12).

Install the clutch outer (page 12-20).

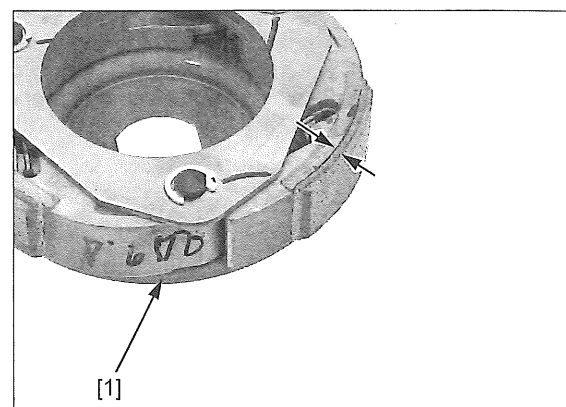

## SIDESTAND

Support the scooter with its centerstand.

Check the sidestand spring [1] for damage or loss of tension.

Check the sidestand [2] assembly for freedom of movement and lubricate the sidestand pivot if necessary.

Check the sidestand switch system:

1. Retract the sidestand.
2. Start the engine.
3. Move the sidestand full down.
4. The engine should stop as the sidestand is lowered.

If there is a problem with the system, check the sidestand switch (page 6-13).

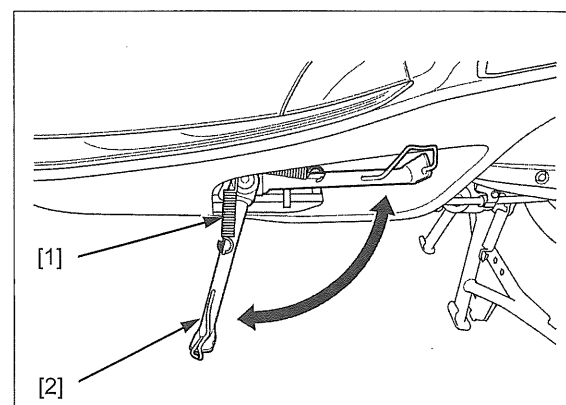

## SUSPENSION

### FRONT

*Loose, worn or damaged suspension parts impair scooter stability and control.*

Check the action of the forks by operating the front brake and compressing the front suspension several times.

Check the entire assembly for signs of leaks, damage, or loose fasteners.

Replace damaged components which cannot be repaired.

Tighten all nuts and bolts.

For fork service (page 17-8).

### REAR

Check the action of the shock absorber by compressing it several times.

Check the entire shock absorber assembly for signs of leaks, damage or loose fasteners.

Replace damaged components which cannot be repaired.

Tighten all nuts and bolts.

For rear shock absorber service (page 18-12).

Support the scooter securely and raise the rear wheel off the ground.

Check for worn engine mounting bushings by grabbing the engine and attempting to move the engine side to side.

For engine bushing service (page 16-6).

## MAINTENANCE

### NUTS, BOLTS, FASTENERS

Check that all chassis nuts and bolts are tightened to their correct torque values (page 1-11).

Check that all cotter pins, safety clips, hose clamps and cable stays are in place and properly secured.

### WHEELS/TIRES

Support the scooter with its centerstand.

Making sure that the fork is not allowed to move, raise the front wheel and check for play.

Check for worn front wheel bearings by grabbing the front wheel and attempting to move the wheel side to side.

Replace the front wheel bearings if any looseness is noted.

Turn the wheel and check that it rotates smoothly with no unusual noises.

If any abnormal conditions are suspected, inspect the front wheel bearings (page 17-6).

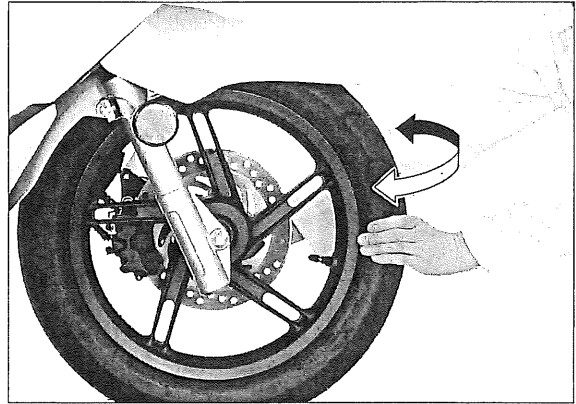

Support the scooter securely and raise the rear wheel.

Check for worn final gear shaft bearings by grabbing the rear wheel and attempting to move the wheel side to side.

Replace the final gear shaft bearings if any looseness is noted.

Turn the wheel and check that it rotates smoothly with no unusual noises.

If any abnormal conditions are suspected, check the final reduction (page 13-6).

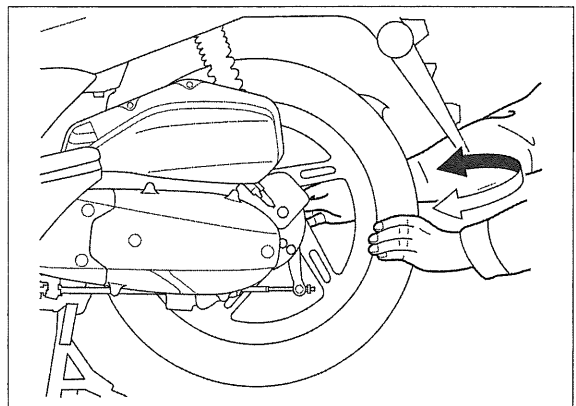

Check the tire pressure with an air pressure gauge when the tires are cold.

**RECOMMENDED TIRE PRESSURE:**

Up to 90 kg (200 lbs) load

FRONT: 200 kPa (2.00 kgf/cm<sup>2</sup>, 29 psi)

REAR: 225 kPa (2.25 kgf/cm<sup>2</sup>, 33 psi)

Up to maximum weight capacity

FRONT: 200 kPa (2.00 kgf/cm<sup>2</sup>, 29 psi)

REAR: 250 kPa (2.50 kgf/cm<sup>2</sup>, 36 psi)

Check the tires for cuts, embedded nails, or other damage.

Check the front wheel and rear wheel for trueness.

**TIRE SIZE:**

FRONT: 90/90-14M/C 46P

REAR: 100/90-14M/C 57P

**TIRE BRAND:**

'13 model:

FRONT: SS-560F (IRC)/TT900F (DUNLOP)

REAR: SS-560R (IRC)/TT900A (DUNLOP)

After '13 model:

FRONT: SS-560F (IRC)

REAR: SS-560R<sub>D</sub> (IRC)

Measure the tread depth at the center of the tires.

Replace the tires when the tread depth reaches the following limits.

**MINIMUM TIRE TREAD DEPTH:**

FRONT: 1.5 mm (0.06 in)

REAR: 2.0 mm (0.08 in)

## STEERING HEAD BEARINGS

**NOTE:**

- Check that the control cables do not interfere with handlebar rotation.

Support the scooter with its centerstand and raise the front wheel off the ground.

Check that the handlebar moves freely from side-to-side. If the handlebar moves unevenly or binds, inspect the steering head bearings (page 17-24).

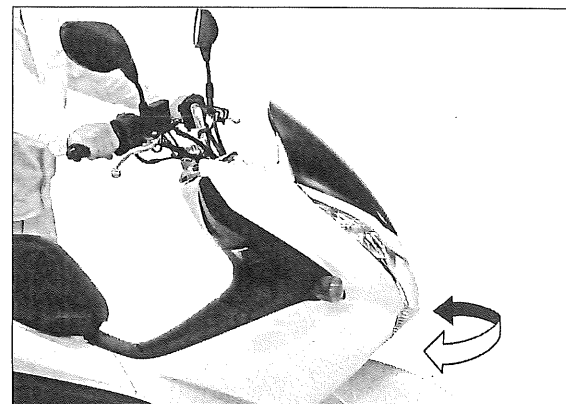

## MAINTENANCE

---

Hold the scooter and check the steering head bearings for wear by moving the fork forward and backward.

If the steering stem has vertical movement, inspect the steering head bearing (page 17-24).

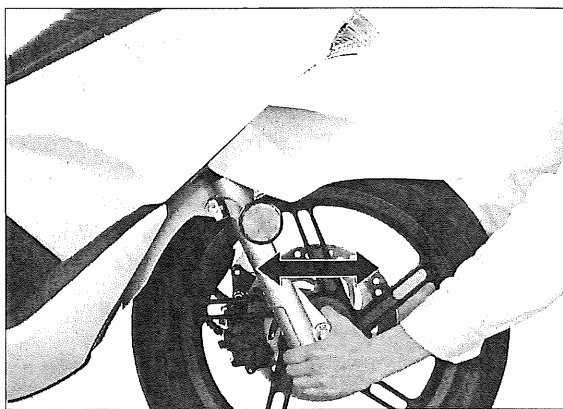



# 4. PGM-FI SYSTEM

---



PGM-FI SYSTEM LOCATION .....	4-2	DTC INDEX (AFTER '13 MODEL) .....	4-16
PGM-FI SYSTEM DIAGRAM .....	4-4	DTC TROUBLESHOOTING ('13 MODEL) .....	4-17
SERVICE INFORMATION .....	4-6	SENSOR UNIT POWER LINE INSPECTION (AFTER '13 MODEL) .....	4-33
PGM-FI SYMPTOM TROUBLESHOOTING ('13 MODEL) .....	4-7	DTC TROUBLESHOOTING (AFTER '13 MODEL) .....	4-34
PGM-FI SYMPTOM TROUBLESHOOTING (AFTER '13 MODEL) .....	4-8	MIL CIRCUIT INSPECTION ('13 MODEL) .....	4-47
PGM-FI CONNECTOR LOCATION ('13 MODEL) .....	4-9	MIL CIRCUIT INSPECTION (AFTER '13 MODEL) .....	4-48
PGM-FI TROUBLESHOOTING INFORMATION ('13 MODEL) .....	4-10	ECM .....	4-49
PGM-FI TROUBLESHOOTING INFORMATION (AFTER '13 MODEL) .....	4-13	ECT SENSOR .....	4-52
DTC INDEX ('13 MODEL) .....	4-15	O <sub>2</sub> SENSOR .....	4-53

# PGM-FI SYSTEM

## PGM-FI SYSTEM LOCATION

'13 model:

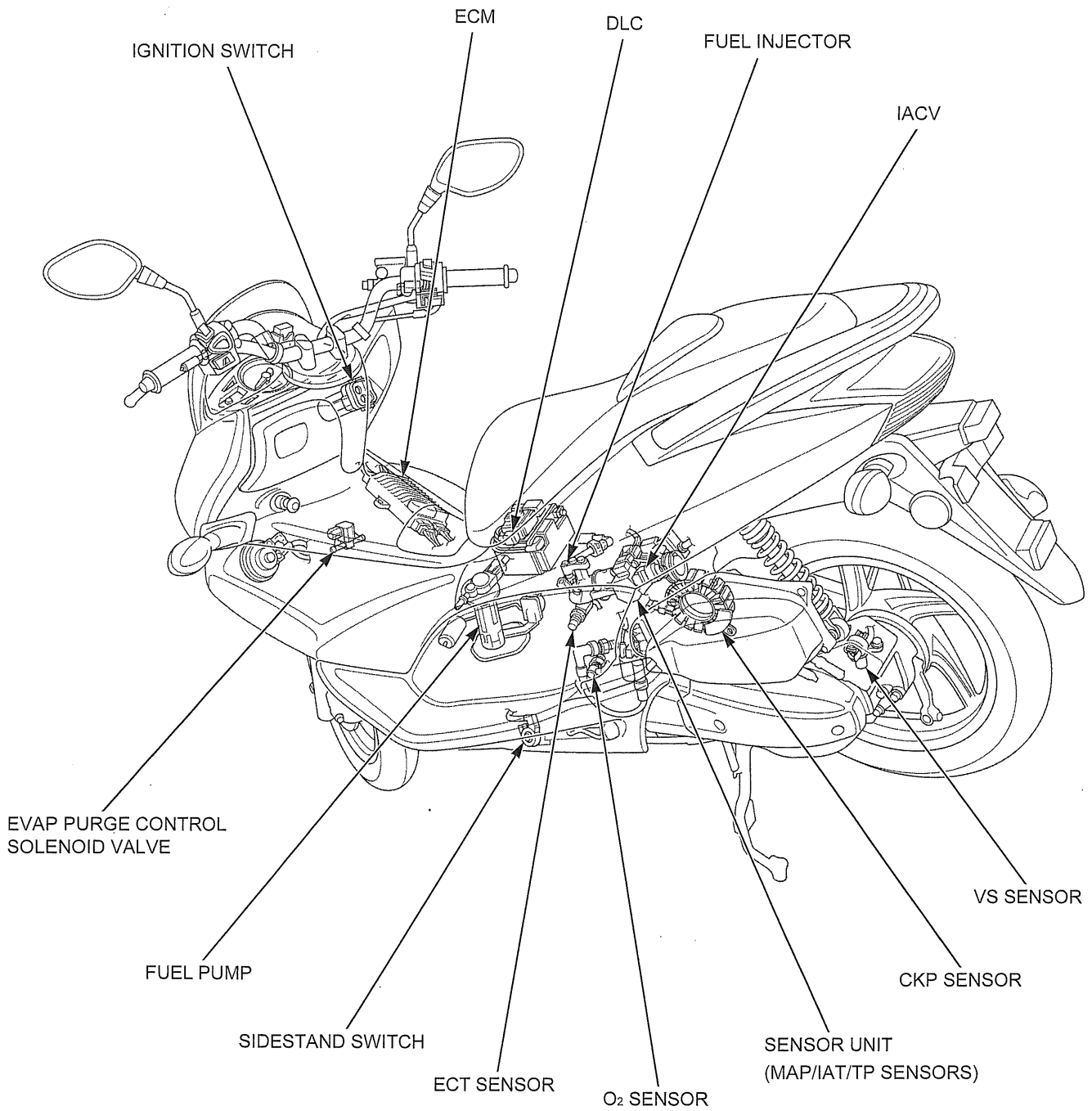

After '13 model:

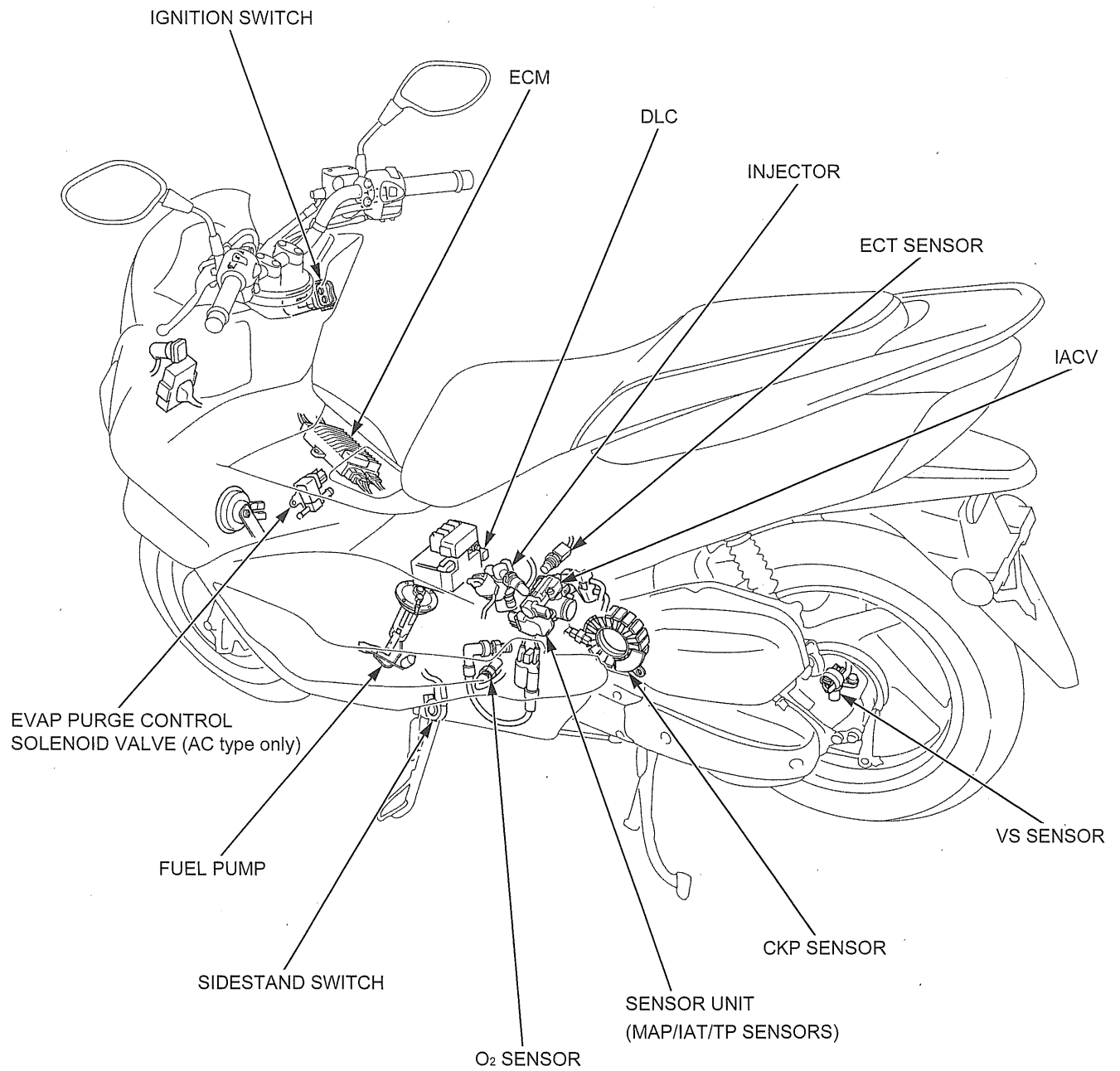

# PGM-FI SYSTEM

## PGM-FI SYSTEM DIAGRAM

'13 model:

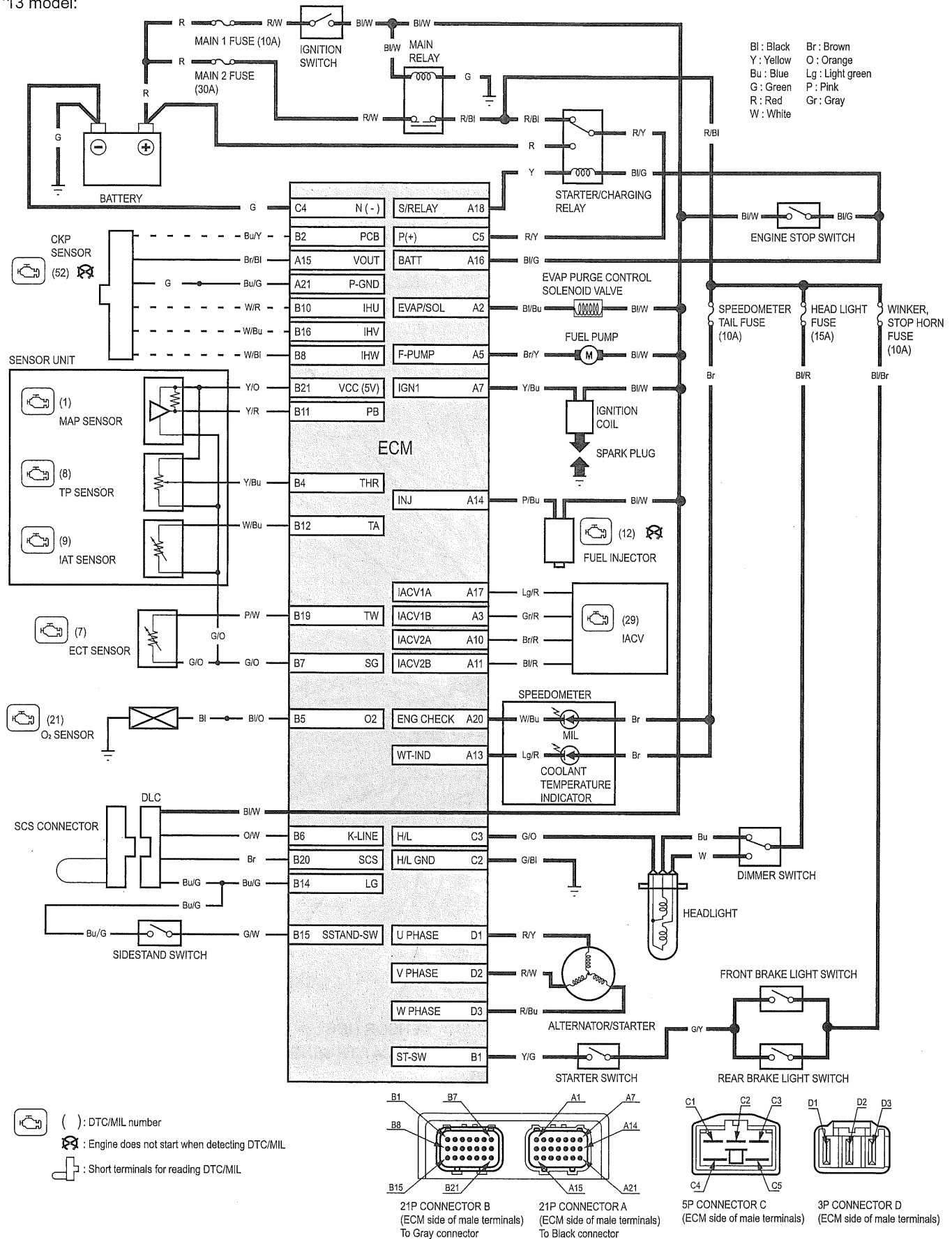

After '13 model:

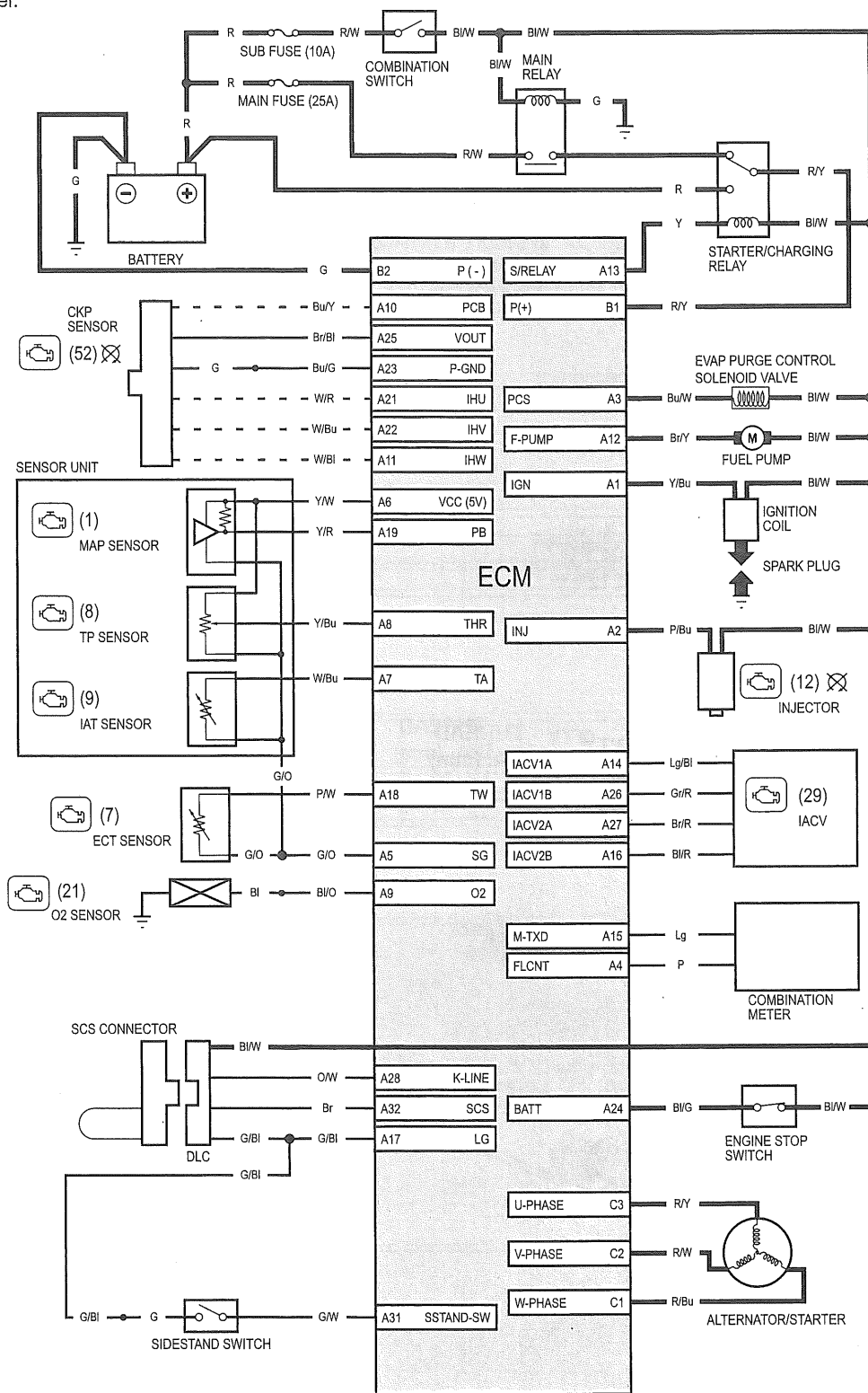

( ): MIL number

⊗ : Engine does not start when detecting MIL

⊥ : Short terminals for reading MIL

Bl : Black  
Y : Yellow  
Bu : Blue  
G : Green  
R : Red  
W : White  
Br : Brown  
O : Orange  
Lg : Light green  
P : Pink  
Gr : Gray

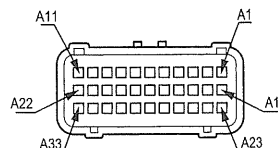

33P (Black) CONNECTOR A (ECM side / male terminal)

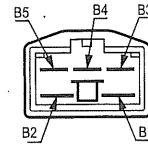

5P CONNECTOR B (ECM side / male terminals)

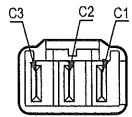

3P (Black) CONNECTOR C (ECM side / male terminals)

## PGM-FI SYSTEM

# SERVICE INFORMATION

## GENERAL

- Use an electric heating element to heat the water for the ECT sensor inspection and keep flammable materials away from the electric heating element. Wear protective clothing, insulated gloves and eye protection.
- A faulty PGM-FI system is often related to poorly connected or corroded connectors. Check those connections before proceeding.
- The PGM-FI system is equipped with the Self-Diagnostic System (page 4-10). If the MIL blinks, follow the Self-Diagnostic Procedures to remedy the problem.
- When checking the PGM-FI, always follow the steps in the troubleshooting flow chart.
- The PGM-FI system is provided with fail-safe function to secure a minimum running capability even when there is any trouble in the system. When any abnormality is detected by the self-diagnosis function, running capability is secured by making use of the numerical values of a situation preset in the simulated program map.  
It must be remembered, however, that when any abnormality is detected in fuel injector, the fail-safe function stops the engine to protect it from damage.
- For PGM-FI system location (page 4-2).
- Use a digital tester for PGM-FI system inspection.

## SPECIFICATIONS

ITEM		SPECIFICATIONS
Engine idle speed		1,700 ± 100 rpm
ECT sensor resistance	(40°C/104°F)	1.0 – 1.3 kΩ
	(100°C/212°F)	0.1 – 0.2 kΩ
Fuel injector resistance (20°C/68°F)		11 – 13 Ω

## TORQUE VALUES

ITEM	Q'TY	THREAD DIA. (mm)	TORQUE N·m (kgf·m, lbf·ft)	REMARKS
ECT sensor	1	10	12 (1.2, 9)	
O <sub>2</sub> sensor	1	12	24.5 (2.5, 18)	

## TOOLS

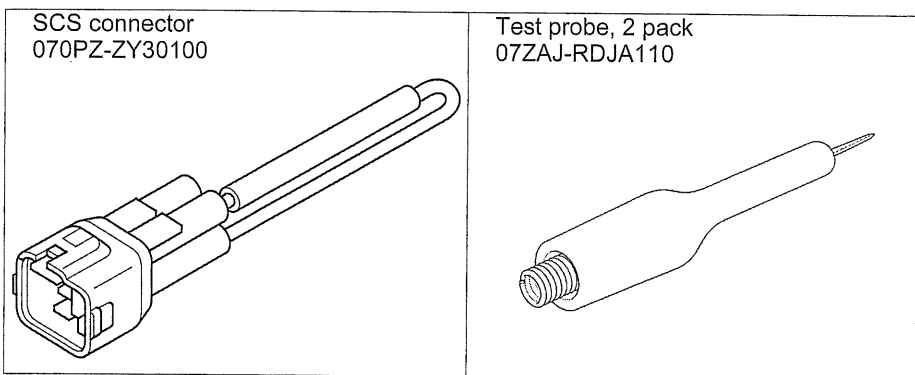

## PGM-FI SYMPTOM TROUBLESHOOTING ('13 MODEL)

When the scooter has one of these symptoms, check the DTC or MIL blinking, refer to the DTC index (page 4-15) and begin the appropriate troubleshooting procedure. If there are no DTC/MIL blinking stored in the ECM memory, do the diagnostic procedure for the symptom, in sequence listed below, until you find cause.

Symptom	Diagnosis procedure	Also check for
Engine does not crank (No fuel pump operation sound when turning ignition switch ON and engine stop switch "O".)	<ol style="list-style-type: none"> <li>1. ECM power/ground circuits malfunction (page 4-50).</li> <li>2. Sensor unit power/ground circuits malfunction (page 4-50).</li> </ol>	<ul style="list-style-type: none"> <li>• Open circuit in the power input and/or ground wire of the ECM</li> <li>• Blown MAIN 2 fuse (30 A)</li> <li>• Faulty engine stop switch</li> </ul>
Engine cranks but won't start (No MIL blinking)	<ol style="list-style-type: none"> <li>1. Crank the engine for more than ten seconds and check the MIL (page 4-10) and execute the troubleshooting according to the MIL.</li> <li>2. Inspect the fuel supply system (page 7-6).</li> </ol>	<ul style="list-style-type: none"> <li>• No fuel to fuel injector <ul style="list-style-type: none"> <li>– Clogged fuel filter</li> <li>– Clogged fuel tank cap breather hole</li> <li>– Pinched or clogged fuel feed hose</li> </ul> </li> <li>– Faulty fuel pump</li> <li>– Faulty fuel pump circuits</li> <li>• Intake air leak</li> <li>• Contaminated/deteriorated fuel</li> <li>• Faulty fuel injector</li> <li>• IACV stuck</li> <li>• Faulty ignition system</li> </ul>
Engine stalls, hard to start, rough idling	<ol style="list-style-type: none"> <li>1. Check the idle speed (page 3-13).</li> <li>2. Check the IACV (page 7-23).</li> <li>3. Inspect the fuel supply system (page 7-6).</li> </ol>	<ul style="list-style-type: none"> <li>• Restricted fuel feed hose</li> <li>• Contaminated/deteriorated fuel</li> <li>• Intake air leak</li> <li>• Restricted fuel tank cap breather</li> <li>• Faulty ignition system</li> </ul>
Backfiring or misfiring during acceleration	Check the ignition system (page 5-5).	
Poor performance (driveability) and poor fuel economy	Inspect the fuel supply system (page 7-6).	<ul style="list-style-type: none"> <li>• Air cleaner element contaminated</li> <li>• Pinched or clogged fuel feed hose</li> <li>• Faulty pressure regulator (fuel pump)</li> <li>• Faulty fuel injector</li> <li>• Faulty ignition system</li> </ul>
Idle speed is below specifications (No MIL blinking)	<ol style="list-style-type: none"> <li>1. Check the idle speed (page 3-13).</li> <li>2. Check the IACV (page 7-23).</li> </ol>	<ul style="list-style-type: none"> <li>• Faulty fuel supply system</li> <li>• Faulty ignition system</li> </ul>
Idle speed is above specifications (No MIL blinking)	<ol style="list-style-type: none"> <li>1. Check the idle speed (page 3-13).</li> <li>2. Check the throttle operation and freeplay (page 3-6).</li> <li>3. Check the IACV (page 7-23).</li> </ol>	<ul style="list-style-type: none"> <li>• Faulty ignition system</li> <li>• Intake air leak</li> <li>• Engine top-end problem</li> <li>• Air cleaner condition</li> </ul>
MIL stays ON or MIL never comes ON at all (Engine operates normally)	Inspect the MIL circuit (page 4-47).	
MIL stays ON (Engine operates normally and No MIL code set)	Inspect the DLC circuit (page 4-47).	

**PGM-FI SYMPTOM TROUBLESHOOTING (AFTER '13 MODEL)**

When the scooter has one of these symptoms, check the MIL blinking, refer to the DTC index (page 4-16) and begin the appropriate troubleshooting procedure. If there are no MIL blinking stored in the ECM memory, do the diagnostic procedure for the symptom, in sequence listed below, until you find cause.

Symptom	Diagnosis procedure	Also check for
Engine does not crank (No fuel pump operation sound when turning ignition switch ON)	<ol style="list-style-type: none"> <li>1. ECM power/ground circuits malfunction (page 4-49).</li> <li>2. Sensor unit power/ground circuits malfunction (page 4-49).</li> </ol>	<ul style="list-style-type: none"> <li>• Open circuit in the power input and/or ground wire of the ECM</li> <li>• Blown MAIN fuse (25 A)</li> </ul>
Engine cranks but won't start (No MIL blinking)	<ol style="list-style-type: none"> <li>1. Crank the engine for more than ten seconds and check the MIL (page 4-13) and execute the troubleshooting according to the MIL.</li> <li>2. Inspect the fuel supply system (page 7-6)</li> </ol>	<ul style="list-style-type: none"> <li>• No fuel to injector                             <ul style="list-style-type: none"> <li>– Clogged fuel filter</li> <li>– Clogged fuel tank cap breather hole</li> <li>– Pinched or clogged fuel feed hose</li> <li>– Faulty fuel pump</li> <li>– Faulty fuel pump circuits</li> </ul> </li> <li>• Intake air leak</li> <li>• Contaminated/deteriorated fuel</li> <li>• Faulty fuel injector</li> <li>• IACV stuck</li> <li>• Faulty ignition system</li> </ul>
Engine stalls, hard to start, rough idling	<ol style="list-style-type: none"> <li>1. Check the idle speed (page 3-13).</li> <li>2. Check the IACV (page 7-22).</li> <li>3. Inspect the fuel supply system (page 7-6).</li> </ol>	<ul style="list-style-type: none"> <li>• Restricted fuel feed hose</li> <li>• Contaminated/deteriorated fuel</li> <li>• Intake air leak</li> <li>• Restricted fuel tank cap breather</li> <li>• Faulty ignition system</li> </ul>
Backfiring or misfiring during acceleration	Check the ignition system (page 5-6).	
Poor performance (driveability) and poor fuel economy	Inspect the fuel supply system (page 7-6).	<ul style="list-style-type: none"> <li>• Air cleaner element contaminated</li> <li>• Pinched or clogged fuel feed hose</li> <li>• Faulty pressure regulator (fuel pump)</li> <li>• Faulty injector</li> <li>• Faulty ignition system</li> </ul>
Poor performance, lack of fuel, or engine start failure with sufficient fuel stored in tank	Fuel supply test (page 7-9).	
Idle speed is below specifications (No MIL blinking)	<ol style="list-style-type: none"> <li>1. Check the idle speed (page 3-13).</li> <li>2. Check the IACV (page 7-22).</li> </ol>	<ul style="list-style-type: none"> <li>• Faulty fuel supply system</li> <li>• Faulty ignition system</li> </ul>
Idle speed is above specifications (No MIL blinking)	<ol style="list-style-type: none"> <li>1. Check the idle speed (page 3-13).</li> <li>2. Check the throttle operation and freeplay (page 3-6).</li> <li>3. Check the IACV (page 7-22).</li> </ol>	<ul style="list-style-type: none"> <li>• Faulty ignition system</li> <li>• Intake air leak</li> <li>• Engine top-end problem</li> <li>• Air cleaner condition</li> </ul>
MIL stays ON or MIL never comes ON at all (Engine operates normally)	Inspect the MIL circuit (page 4-48).	
MIL stays ON (Engine operates normally and No DTC set)	Inspect the DLC circuit (page 4-48).	



# PGM-FI CONNECTOR LOCATION ('13 MODEL)

NOTE 1: Remove the battery maintenance lid (page 20-7).  
 NOTE 2: Remove the right front cover (page 2-15).

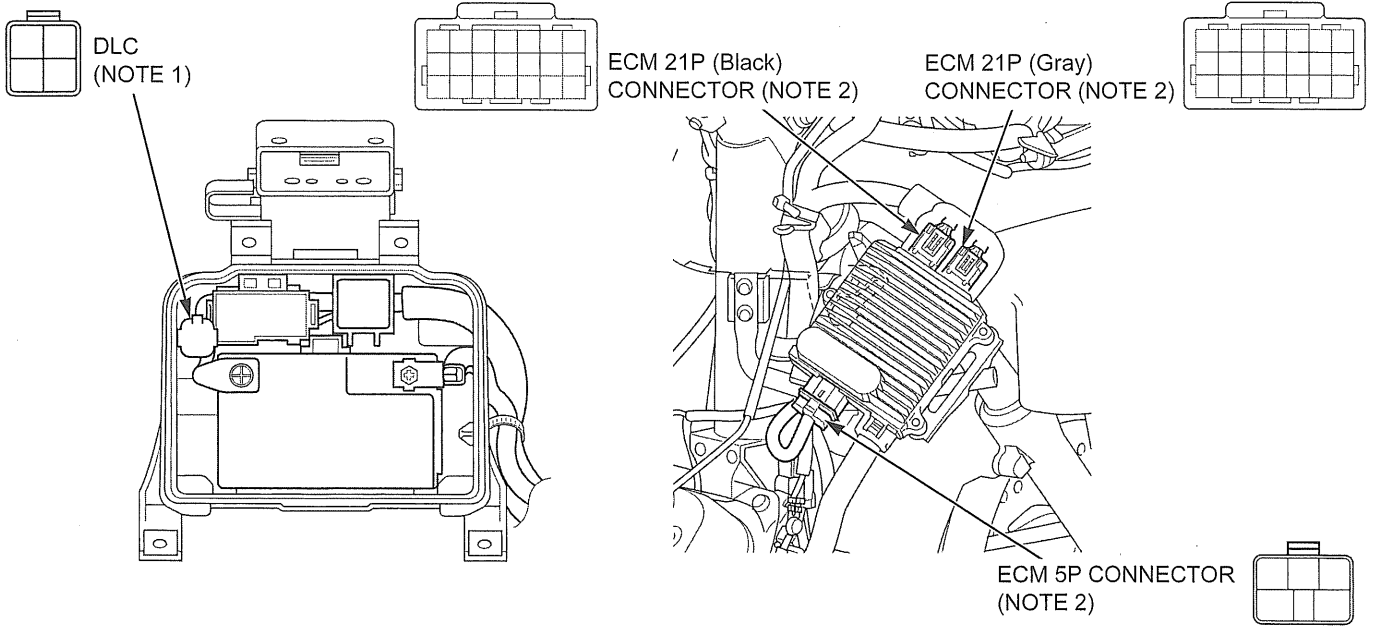

NOTE 3: Remove the luggage box (page 2-25).  
 NOTE 4: Remove the right side cover (page 2-8).  
 NOTE 5: Remove the left side cover (page 2-8).  
 NOTE 6: Refer to page 4-53.

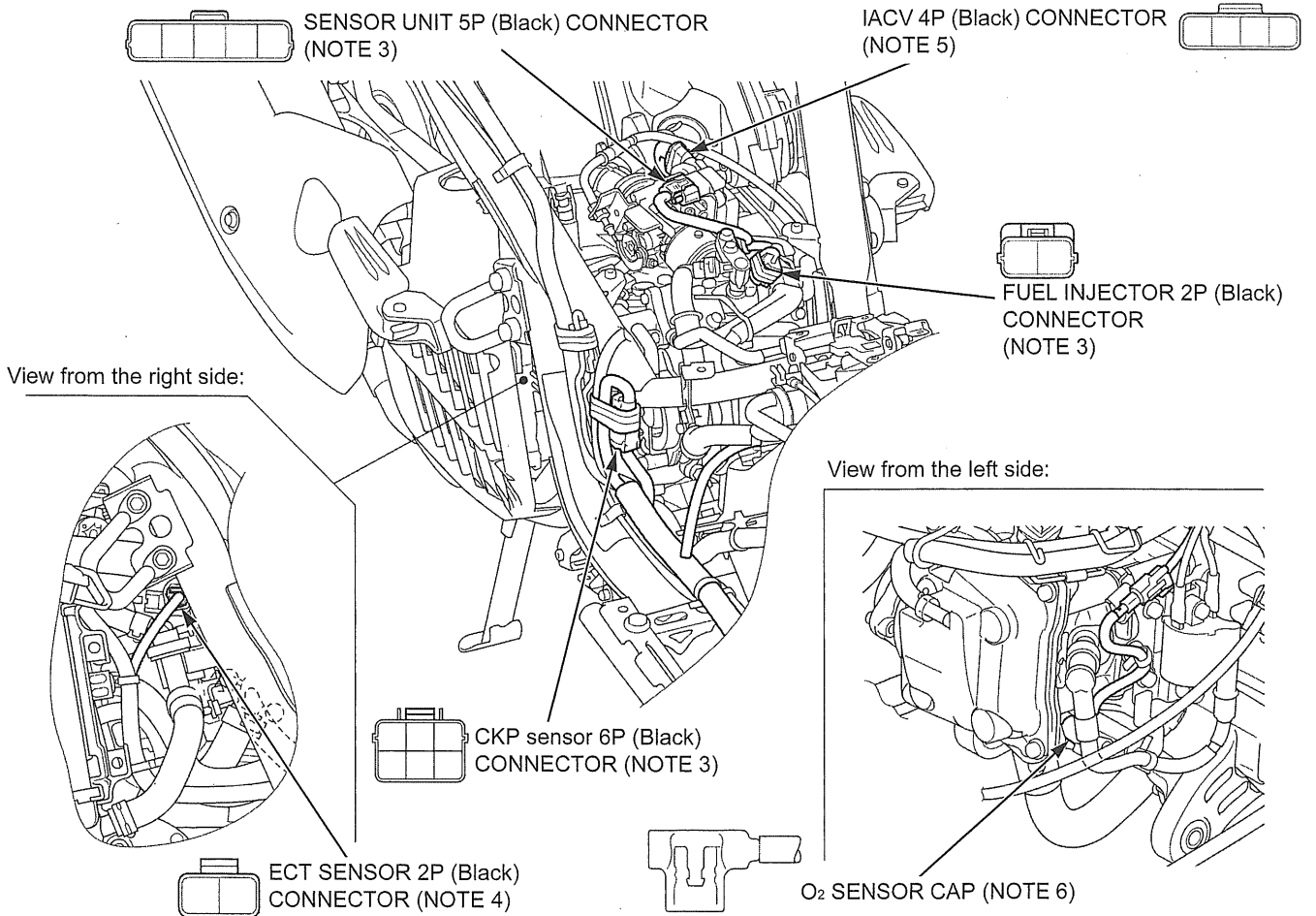

## PGM-FI SYSTEM

# PGM-FI TROUBLESHOOTING INFORMATION ('13 MODEL)

## GENERAL TROUBLESHOOTING

### Intermittent Failure

The term "intermittent failure" means a system may have had a failure, but it checks OK now. If the MIL does not come on, check for poor contact or loose pins at all connectors related to the affected circuit. If the MIL was on, but then went out, the original problem may be intermittent.

### Opens and Shorts

"Opens" and "Shorts" are common electrical terms. An open is a break in a wire or at a connection. A short is an accidental connection of a wire to ground or to another wire. In simple electronics, this usually means something will not work at all. With ECMs this can mean something may work, but not the way it's supposed to.

### If the MIL has come on

Refer to DTC READOUT (page 4-11).

### If the MIL did not stay on

If the MIL did not stay on, but there is a driveability problem, do the SYMPTOM TROUBLESHOOTING (page 4-7).

## SYSTEM DESCRIPTION

### SELF-DIAGNOSIS SYSTEM

The PGM-FI system is equipped with the self-diagnostic system. When any abnormality occurs in the system, the ECM turns on the MIL (Malfunction Indicator Lamp) and stores a DTC in its erasable memory.

### FAIL-SAFE FUNCTION

The PGM-FI system is provided with a fail-safe function to secure a minimum running capability even when there is trouble in the system. When any abnormality is detected by the self-diagnosis function, running capability is maintained by pre-programmed value in the simulated program map. When any abnormality is detected in the fuel injector and/or CKP sensor, the fail-safe function stops the engine to protect it from damage.

### DTC (Diagnostic Trouble Code)

- The DTC is composed of a main code and a sub code and it is displayed as a hyphenated number when retrieved from the ECM with the MCS tester.
  - The digits in front of the hyphen are the main code, they indicate the component of function failure.
  - The digits behind the hyphen are the sub code, they detail the specific symptom of the component or function failure.For example, in the case of the TP sensor:
  - DTC 8 - 1 = (TP sensor voltage) - (lower than the specified value).
  - DTC 8 - 2 = (TP sensor voltage) - (higher than the specified value).
- The MAP, ECT, TP and IAT sensor diagnosis will be made according to the voltage output of the affected sensor.
  - If a failure occurs, the ECM determines the Function Failure, compares the sensor voltage output to the standard value, and then outputs the corresponding DTC to the MCS Tester.

### MIL BLINK PATTERN

- DTC can be read by the MIL [1] blink pattern.
- In case the ECM does not detect any problem at present, when the ignition switch is turned ON and engine stop switch "O", the MIL will stay on for a few seconds, then go off.
- In case the ECM detects the problem at present, when the ignition switch is turned ON and engine stop switch "O", the MIL will stay on for a few seconds and go off, then the MIL blinks the DTC (Except MIL 52 blinks: CKP sensor).
- The engine must be cranked to indicate MIL 52 blinks (CKP sensor), as the ECM can detect CKP sensor malfunction only when the engine is cranking.
- The MIL has two types of blinks, a long blink and short blink. The long blinking lasts for 1.3 seconds, the short blinking lasts for 0.3 seconds. One long blink is the equivalent to ten short blinks. For example, when two long blinks are followed by nine short blinks, the MIL is 29 (two long blinks = 29 blinks, plus nine short blinks).
- The MIL will start blinking when the ignition switch is ON and engine stop switch "O" or engine revs are below 2,000 rpm. In any other conditions, the MIL will illuminate and stay on.

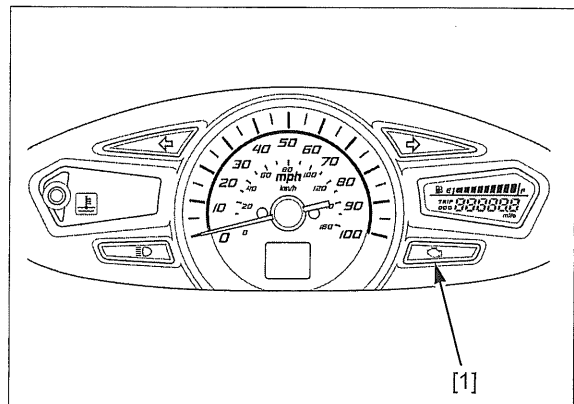

### MIL CHECK

When the ignition switch is turned ON and engine stop switch "O", the MIL will stay on for a few seconds, then go off. If the MIL does not come on or stays on when the ignition switch is turned ON, inspect the MIL circuit (page 4-47).

**CURRENT DTC/FREEZE DTC**

The DTC is indicated in two ways according to the failure status.

- In case the ECM detects the problem at present, the MIL will start blinking the DTC. It is possible to read out the MIL blink pattern as the current DTC.
- In case the ECM does not detect any problem at present but has a problem stored in its memory, the MIL will not blink. If it is necessary to retrieve the past problem, read out the stored DTC by following the DTC readout procedure (page 4-11).

**MCS TESTER INFORMATION**

- The MCS can readout the DTC, freeze data, current data and other ECM condition.

**How to connect the MCS Tester**

Remove the dummy connector from the DLC (page 4-11).  
Connect the MCS tester to the DLC.

Turn the ignition switch ON and engine stop switch "O", check the DTC and freeze data.

- Freeze data indicates the engine conditions when the first malfunction was detected.

**ECM reset**

The MCS can reset the ECM data including the DTC, freeze data and some learning memory.

**DTC READOUT**

Support the scooter with its centerstand.

Turn the ignition switch ON and engine stop switch "O", check the MIL.

- When the ignition switch is turned ON, the MIL will stay on for a few seconds, then go off.

If the MIL stays on or blinks, connect the MCS Tester to the DLC (page 4-11).

Crank the engine for more than ten seconds and check the MIL.

- MIL 52 blinks (CKP sensor) is indicated only when the engine is cranked.

If the MIL stays on or blinks, connect the MCS Tester to the DLC (page 4-11).

To read the DTC with the MIL blinking, refer to the following procedure.

**Reading DTC with the MIL**

1. Turn the ignition switch OFF.
2. Remove the battery maintenance lid (page 20-7).
3. Remove the dummy connector [1] from the DLC [2] and short the DLC terminals using the special tool.

**TOOL:**

[3] SCS connector                      070PZ-ZY30100

**CONNECTION: Brown – Blue/green**

4. Turn the ignition switch ON and engine stop switch "O", read the MIL blinks and refer to the troubleshooting index (page 4-15).

- If the ECM has stored DTC in its memory, the MIL will illuminate 0.3 seconds and go off, then start blinking as its DTC when you turn the ignition switch ON and engine stop switch "O".

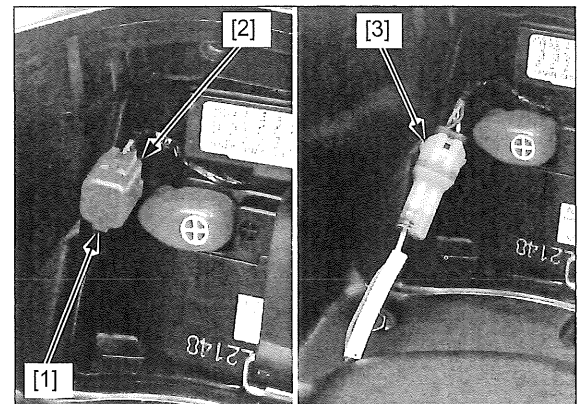

## PGM-FI SYSTEM

### ERASING DTC

- The stored DTC can not be erased by simply disconnecting the battery.

Connect the MCS tester to the DLC (page 4-11).

Clear the DTC with the MCS while the engine is stopped.

To clear the DTC without MCS, refer to the following procedure.

#### How to clear the DTC with SCS connector

1. Connect the SCS connector to the DLC (page 4-11).
2. Turn the ignition switch ON and engine stop switch "O".
3. Disconnect the SCS connector [1] from the DLC [2].  
Connect the SCS connector to the DLC again while the MIL stays ON about 5 seconds (reset receiving pattern).
4. The stored DTC is erased if the MIL goes off and starts blinking (successful pattern).
  - The DLC must be jumped while the MIL lights. If not, the MIL will not start blinking. In that case, turn the ignition switch OFF and try again from step 3.
  - Note that the self-diagnostic memory cannot be erased if the ignition switch is turned "OFF" before the MIL starts blinking.

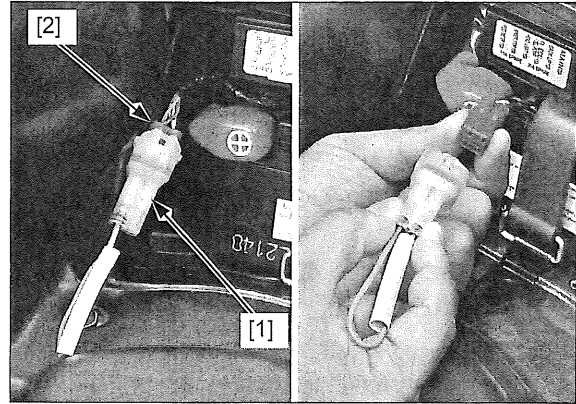

### CIRCUIT INSPECTION

#### INSPECTION AT ECM CONNECTOR

- Always clean around and keep any foreign material away from the connector before disconnecting it.
- A faulty PGM-FI system is often related to poorly connected or corroded connections. Check those connections before proceeding.
- When testing at connector (wire harness side) terminal, always use the test probe. Insert the test probe into the connector terminal, then connect the digital multimeter probe to the test probe.

#### TOOL:

[1] Test probe, 2 pack 07ZAJ-RDJA110

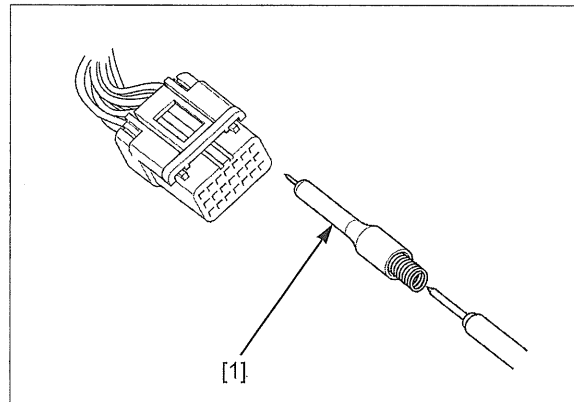

# PGM-FI TROUBLESHOOTING INFORMATION (AFTER '13 MODEL)

## GENERAL TROUBLESHOOTING

### Intermittent Failure

The term "intermittent failure" means a system may have had a failure, but it checks OK now. If the MIL does not come on, check for poor contact or loose pins at all connectors related to the circuit that of the troubleshooting. If the MIL was on, but then went out, the original problem may be intermittent.

### Opens and Shorts

"Opens" and "Shorts" are common electrical terms. An open is a break in a wire or at a connection. A short is an accidental connection of a wire to ground or to another wire. In simple electronics, this usually means something will not work at all. With ECMs this can mean something may work, but not the way it's supposed to.

### If the MIL has come on

Refer to DTC READOUT (page 4-11).

### If the MIL did not stay on

If the MIL did not stay on, but there is a driveability problem, do the SYMPTOM TROUBLESHOOTING (page 4-8).

## SYSTEM DESCRIPTION

### SELF-DIAGNOSIS SYSTEM

The PGM-FI system is equipped with the self-diagnostic system. When any abnormality occurs in the system, the ECM turns on the MIL and stores a DTC in its erasable memory.

### FAIL-SAFE FUNCTION

The PGM-FI system is provided with a fail-safe function to secure a minimum running capability even when there is trouble in the system. When any abnormality is detected by the self-diagnosis function, running capability is maintained by pre-programmed value in the simulated program map. When any abnormality is detected in the fuel injector, the fail-safe function stops the engine to protect it from damage.

### DTC (Diagnostic Trouble Code)

- The DTC is composed of a main code and a sub code and it is displayed as a hyphenated number when retrieved from the ECM with the MCS.  
The digits in front of the hyphen are the main code, they indicate the component of function failure.  
The digits behind the hyphen are the sub code, they detail the specific symptom of the component or function failure.  
For example, in the case of the TP sensor:
  - DTC 08 – 1 = (TP sensor voltage) – (lower than the specified value)
  - DTC 08 – 2 = (TP sensor voltage) – (higher than the specified value).
- The ECT and TP sensor diagnosis will be made according to the voltage output of the affected sensor.  
If a failure occurs, the ECM determines the Function Failure, compares the sensor voltage output to the standard value, and then outputs the corresponding DTC to the MCS.

### MIL Blink Pattern

- If the MCS is not available, DTC can be read from the ECM memory by the MIL blink pattern.
- The number of MIL blinks is the equivalent to the main code of the DTC (the sub code cannot be displayed by the MIL).
- The MIL will blink the current DTC, in case the ECM detects the problem at present, when the ignition switch is ON. The MIL will stay ON when the engine speed is over 2000 rpm.
- The MIL has two types of blinks, a long blink and short blink. The long blinking lasts for 1.3 seconds, the short blinking lasts for 0.3 seconds. One long blink is the equivalent of ten short blinks. For example, when two long blinks are followed by five short blinks, the MIL is 25 (two long blinks = 20 blinks, plus five short blinks).
- When the ECM stores more than one DTC, the MIL will indicate them by blinking in the order from the lowest number to highest number.

### MIL Check

When the ignition switch is turned ON, the MIL will stay on for a few seconds, then go off. If the MIL does not come on, troubleshoot the MIL circuit (page 4-48).

### CURRENT DTC/FREEZE DTC

The DTC is indicated in two ways according to the failure status.

- In case the ECM detects the problem at present, the MIL will come on and the MIL will start to blink as its DTC. It is possible to readout the MIL blink pattern as the current DTC.
- In case the ECM does not detect any problem at present but has a problem stored in its memory, the MIL will not light and blink. If it is necessary to retrieve the past problem, readout the freeze DTC by following the DTC readout procedure (page 4-11).

## PGM-FI SYSTEM

### MCS INFORMATION

- The MCS can readout the DTC, freeze data, current data and other ECM condition.

#### How to connect the MCS

Turn the ignition switch OFF.

Remove the dummy connector from the DLC (page 4-11).

Connect the MCS to the DLC.

Turn the ignition switch ON, check the DTC and freeze data.

#### NOTE:

Freeze data indicates the engine conditions when the first malfunction was detected.

### DTC READOUT

Start the engine and check the MIL.

#### NOTE:

When the ignition switch is turned ON, the MIL will stay on for a few seconds, then go off.

If the MIL stays on or blinks, read the DTC or freeze data and follow the DTC index (page 4-16).

To read the DTC with the MIL blinking, refer to the following procedure.

#### Reading DTC with the MIL

1. Turn the ignition switch OFF.
2. Remove the battery maintenance lid (page 20-7).
3. Remove the dummy connector [1] from the DLC [2] and short the DLC terminals using the special tool.

#### TOOL:

[3] SCS connector 070PZ-ZY30100

Connection: Brown – Green/black

4. Turn the ignition switch ON, read and note the MIL blinks and refer to the DTC index (page 4-16).

#### NOTE:

- If the ECM has any DTC in its memory, the MIL will start blinking.

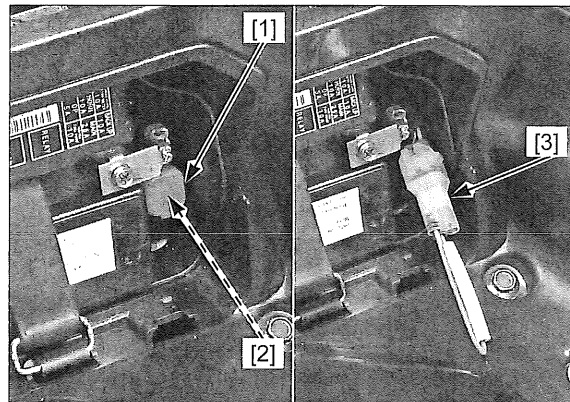

### ERASING DTC

1. Turn the ignition switch OFF.
2. Remove the battery maintenance lid (page 20-7).
3. Remove the dummy connector [1] from the DLC [2] and short the DLC terminals using the special tool.

#### TOOL:

[3] SCS connector 070PZ-ZY30100

Connection: Brown – Green/black

4. Turn the ignition switch ON.
5. Remove the special tool from the DLC.
6. The MIL will light for approximately 5 seconds. While the MIL lights, short the DLC terminals again with the special tool. The self-diagnostic memory is erased if the MIL goes off and starts blinking.

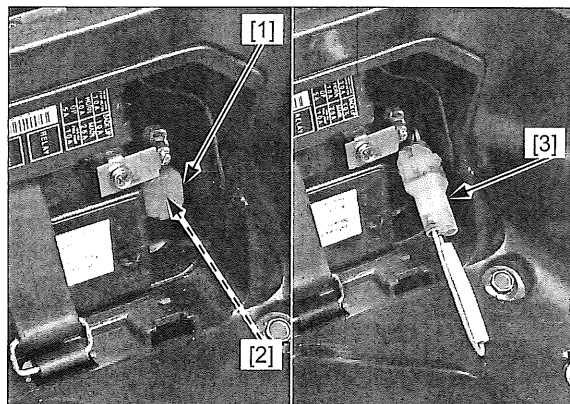

#### NOTE:

- The DLC must be jumped while the MIL lights. If not, the MIL will not start blinking.
- Note that the self-diagnostic memory cannot be erased if the ignition switch is turned OFF before the MIL starts blinking.

## CIRCUIT INSPECTION

### INSPECTION AT ECM CONNECTOR

- Always clean around and keep any foreign material away from the ECM 33P (Black) connector before disconnecting it.
- A faulty PGM-FI system is often related to poorly connected or corroded connections. Check those connections before proceeding.
- In testing at ECM 33P (Black) connector (wire side) terminal, always use the test probe [1]. Insert the test probe into the connector terminal, then attach the digital multimeter probe to the test probe.

**TOOL:**

Test probe, 2 pack

07ZAJ-RDJA110

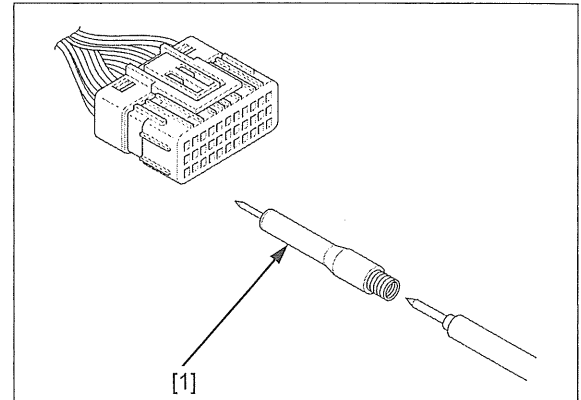

## DTC INDEX ('13 MODEL)

DTC (MIL blinks)	Function Failure	Symptom/Fail-safe function	Refer to
1-1 (1)	MAP sensor circuit low voltage (less than 0.200 V) • MAP sensor or its circuit malfunction	• Engine operates normally • Pre-program value: 61 kPa	4-17
1-2 (1)	MAP sensor circuit high voltage (more than 3.848 V) • Loose or poor contact of the sensor unit 5P (Black) connector • MAP sensor or its circuit malfunction	• Engine operates normally • Pre-program value: 61 kPa	4-19
7-1 (7)	ECT sensor circuit low voltage (less than 0.078 V) • ECT sensor or its circuit malfunction	• Hard start at a low temperature • Pre-program value: 82 °C/180 °F	4-20
7-2 (7)	ECT sensor circuit high voltage (more than 4.922 V) • Loose or poor contact of the ECT sensor connector • ECT sensor or its circuit malfunction	• Hard start at a low temperature • Pre-program value: 82 °C/180 °F	4-21
8-1 (8)	TP sensor circuit low voltage (less than 0.200 V) • Loose or poor contact of the sensor unit 5P (Black) connector • TP sensor or its circuit malfunction	• Poor engine acceleration • Pre-program value: 0°	4-22
8-2 (8)	TP sensor circuit high voltage (more than 4.902 V) • TP sensor or its circuit malfunction	• Poor engine acceleration • Pre-program value: 0°	4-24
9-1 (9)	IAT sensor circuit low voltage (less than 0.078 V) • IAT sensor or its circuit malfunction	• Engine operates normally • Pre-program value: 35 °C/95 °F	4-25
9-2 (9)	IAT sensor circuit high voltage (more than 4.922 V) • Loose or poor contact of the sensor unit 5P (Black) connector • IAT sensor or its circuit malfunction	• Engine operates normally • Pre-program value: 35 °C/95 °F	4-26
12-1 (12)	Fuel injector malfunction • Loose or poor contact of the fuel injector connector • Fuel injector or its circuit malfunction	• Engine does not start • Fuel injector, fuel pump and ignition coil shut down	4-27
21-1 (21)	O <sub>2</sub> sensor malfunction • Loose or poor contact of the O <sub>2</sub> sensor connector • O <sub>2</sub> sensor or its circuit malfunction	• Engine operates normally	4-29
29-1 (29)	IACV malfunction • Loose or poor contact of the IACV connector • IACV or its circuit malfunction	• Engine stalls, hard to start, rough idling	4-30
52-1 (52)	CKP sensor malfunction • Loose or poor contact of the CKP sensor connector • CKP sensor or its circuit malfunction	• Engine does not start	4-32

## PGM-FI SYSTEM

### DTC INDEX (AFTER '13 MODEL)

**NOTE:**

- If the MCS is not used, perform all of the inspection on the corresponding main code (digits in front of hyphen) of the DTC.

DTC	Function Failure	Symptom/Fail-safe function	Refer to
1-1	MAP sensor circuit low voltage (less than 0.21 V) • MAP sensor or its circuit malfunction	• Engine operates normally • Pre-program value: 63 kPa	4-34
1-2	MAP sensor circuit high voltage (more than 3.85 V) • Loose or poor contact of the sensor unit connector • MAP sensor or its circuit malfunction	• Engine operates normally • Pre-program value: 63 kPa	4-35
7-1	ECT sensor circuit low voltage (less than 0.08 V) • ECT sensor or its circuit malfunction	• Hard start at a low temperature • Pre-program value: 82°C • Cooling fan turns on	4-36
7-2	ECT sensor circuit high voltage (more than 4.91 V) • Loose or poor contact of the ECT sensor connector • ECT sensor or its circuit malfunction	• Hard start at a low temperature • Pre-program value: 82°C • Cooling fan turns on	4-37
8-1	TP sensor circuit low voltage (less than 0.21 V) • Loose or poor contact of the sensor unit connector • TP sensor or its circuit malfunction	• Poor engine acceleration • Pre-program value: 0°	4-38
8-2	TP sensor circuit high voltage (more than 4.89 V) • TP sensor or its circuit malfunction	• Poor engine acceleration • Pre-program value: 0°	4-39
9-1	IAT sensor circuit low voltage (less than 0.08 V) • IAT sensor or its circuit malfunction	• Engine operates normally • Pre-program value: 35°C	4-40
9-2	IAT sensor circuit high voltage (more than 4.91 V) • Loose or poor contact of the sensor unit connector • IAT sensor or its circuit malfunction	• Engine operates normally • Pre-program value: 35°C	4-41
12-1	Fuel injector circuit malfunction • Loose or poor contact of the fuel injector connector • Fuel injector or its circuit malfunction	• Engine does not start • Fuel injector, fuel pump and ignition coil shut down	4-42
21-1	O <sub>2</sub> sensor malfunction • Loose or poor contact of the O <sub>2</sub> sensor connector • O <sub>2</sub> sensor or its circuit malfunction	• Engine operates normally	4-43
29-1	IACV circuit malfunction • Loose or poor contact of the IACV connector • IACV or its circuit malfunction	• Engine stalls, hard to start, rough idling	4-44
33-2*	ECM EEPROM malfunction • Faulty ECM	• Engine stalls, hard to start, rough idling • Does not hold the self diagnosis data	4-46
52-1	CKP sensor malfunction • Loose or poor contact of the CKP sensor connector • CKP sensor or its circuit malfunction	• Engine does not start	4-46

\* The MIL does not blink (DTC can be readout/erased only by MCS)



## DTC TROUBLESHOOTING ('13 MODEL)

### DTC 1-1 (MAP SENSOR LOW VOLTAGE)

- Before starting the inspection, check for loose or poor contact on the sensor unit 5P (Black) connector and recheck the DTC.

#### 1. MAP Sensor System Inspection 1

Turn the ignition switch ON and engine stop switch "O".

Check the MAP sensor with the MCS tester.

**Is about 0 V indicated?**

**YES** – GO TO STEP 2.

- NO** –
- Intermittent failure
  - Loose or poor contact on the sensor unit 5P (Black) connector

#### 2. MAP Sensor System Inspection 2

Turn the ignition switch OFF.

Disconnect the sensor unit 5P (Black) connector.

Turn the ignition switch ON.

Measure the voltage between the sensor unit 5P (Black) connector [1] of the wire harness side and ground.

**CONNECTION:**

**Yellow/orange (+) – Green/orange(-)**

**STANDARD: 4.75 – 5.25 V**

**Is the voltage within 4.75 – 5.25 V?**

**YES** – GO TO STEP 3.

**NO** – GO TO STEP 4.

#### 3. MAP Sensor Output Voltage Inspection

Measure the voltage between the sensor unit 5P (Black) connector [1] of the wire harness side and ground.

**CONNECTION: Yellow/red (+) – Green/orange(-)**

**STANDARD: 3.80 – 5.25 V**

**Is the voltage within 3.80 – 5.25 V?**

**YES** – Replace the sensor unit with a new one and recheck (Faulty MAP sensor)

**NO** – GO TO STEP 5.

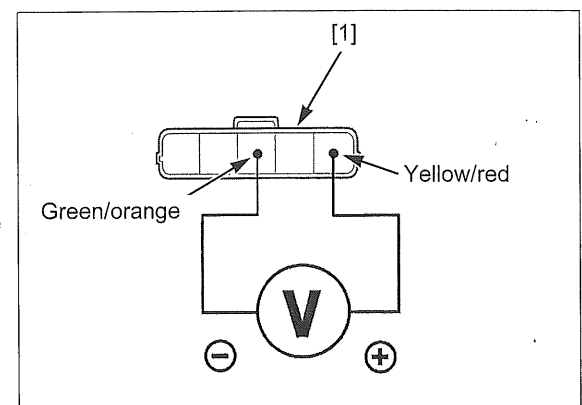
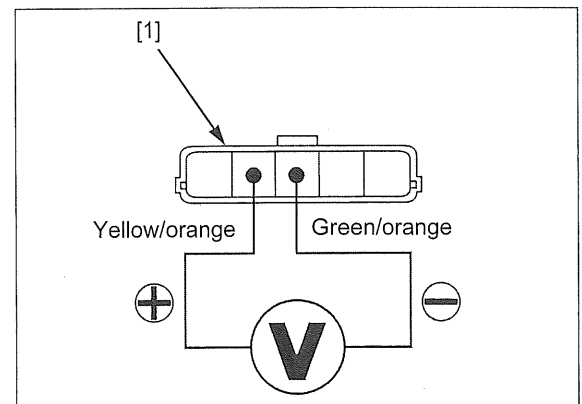

**4. MAP Sensor Input Line Open Circuit Inspection**

Turn the ignition switch OFF.  
Disconnect the ECM 21P (Gray) connector.

Check for continuity between the ECM 21P (Gray) connector [1] of the wire harness side and sensor unit 5P (Black) connector [2] of the wire harness side.

**CONNECTION:**

Yellow/orange – B21 (Yellow/orange)

Green/orange – B7 (Green/orange)

**STANDARD:** Continuity

**TOOL:**

Test probe, 2 pack                      07ZAJ-RDJA110

*Is there continuity?*

**YES** – Replace the ECM with a new one and recheck.

**NO** – • Open circuit in the Yellow/orange wire  
• Open circuit in the Green/orange wire

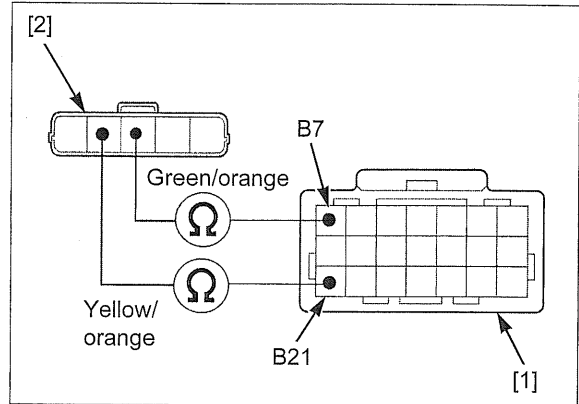

**5. MAP Sensor Output Line Open Circuit Inspection**

Turn the ignition switch OFF.  
Disconnect the ECM 21P (Gray) connector.

Check for continuity between the ECM 21P (Gray) connector [1] of the wire harness side and sensor unit 5P (Black) connector [2] of the wire harness side.

**CONNECTION:** Yellow/red – B11 (Yellow/red)

**STANDARD:** Continuity

**TOOL:**

Test probe, 2 pack                      07ZAJ-RDJA110

*Is there continuity?*

**YES** – Replace the ECM with a new one and recheck.

**NO** – Open circuit in the Yellow/red wire

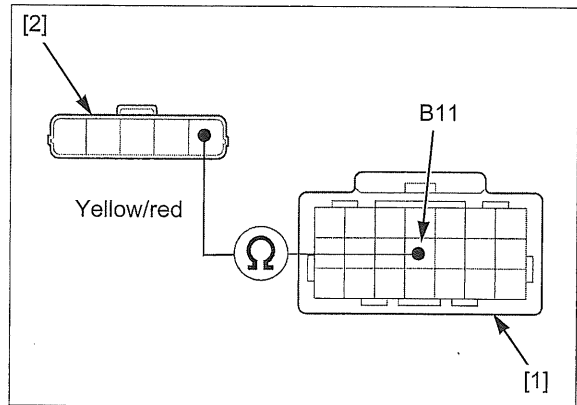

## DTC 1-2 (MAP SENSOR HIGH VOLTAGE)

### 1. MAP Sensor System Inspection

Turn the ignition switch ON and engine stop switch "O".

Check the MAP sensor with the MCS tester.

**Is about 5 V indicated?**

**YES** – GO TO STEP 2.

**NO** – Intermittent failure

### 2. MAP Sensor Inspection

Turn the ignition switch OFF.

Disconnect the sensor unit 5P (Black) connector.

Connect the sensor unit 5P (Black) connector [1] terminals of the wire harness side with a jumper wire [2].

**CONNECTION: Yellow/red – Green/orange**

Turn the ignition switch ON.

Check the MAP sensor with the MCS tester.

**Is about 0 V indicated?**

**YES** – Replace the sensor unit with a new one and recheck (Faulty MAP sensor)

**NO** – GO TO STEP 3.

### 3. MAP Sensor Output Line Open Circuit Inspection

Turn the ignition switch OFF.

Disconnect the ECM 21P (Gray) connector.

Check for continuity between the sensor unit 5P (Black) connector [1] and ECM 21P (Gray) connector [2] of the wire harness side.

**CONNECTION: Yellow/Red – B11 (Yellow/red)**

**STANDARD: Continuity**

**Is there continuity?**

**YES** – GO TO STEP 4.

**NO** – Open circuit in the Yellow/red wire

### 4. MAP Sensor Ground Line Open Circuit Inspection

Check for continuity between the sensor unit 5P (Black) connector [1] and ECM 21P (Gray) connector [2] of the wire harness side.

**CONNECTION:**

**Green/orange – B7 (Green/orange)**

**STANDARD: Continuity**

**Is there continuity?**

**YES** – Replace the ECM with a new one and recheck.

**NO** – Open circuit in the Green/orange wire

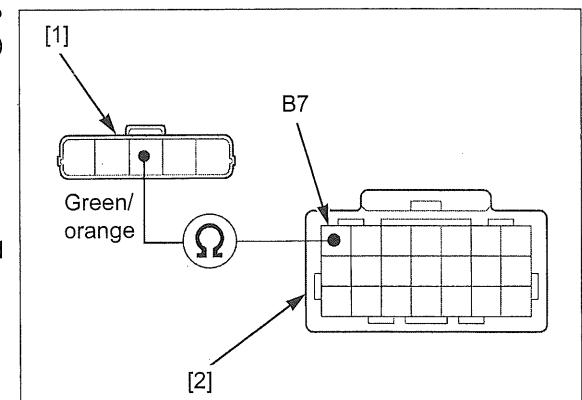
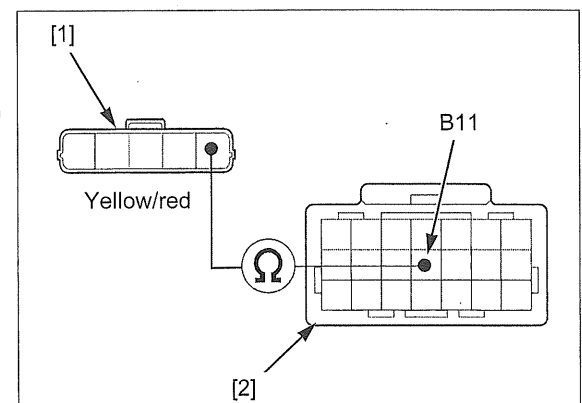
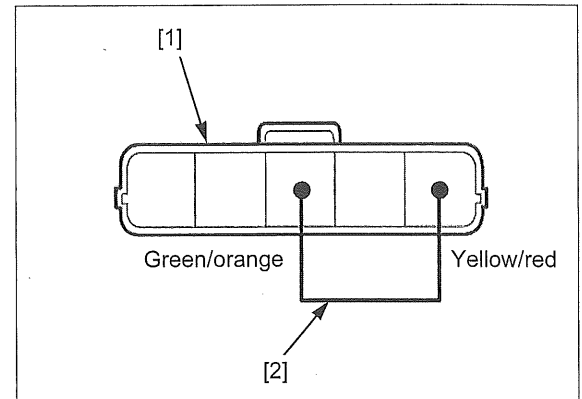

**DTC 7-1 (ECT SENSOR LOW VOLTAGE)**

**1. ECT Sensor System Inspection**

Turn the ignition switch ON and engine stop switch "O".  
Check the ECT sensor with the MCS tester.

**Is about 0 V indicated?**

**YES** – GO TO STEP 2.

**NO** – Intermittent failure

**2. ECT Sensor Inspection**

Turn the ignition switch OFF.  
Disconnect the ECT sensor 2P (Black) connector.

Turn the ignition switch ON.  
Check the ECT sensor with the MCS tester.

**Is about 0 V indicated?**

**YES** – GO TO STEP 4.

**NO** – GO TO STEP 3.

**3. ECT Sensor Resistance Inspection**

Turn the ignition switch OFF.  
Measure the resistance at the 2P connector [1] terminals of the ECT sensor side.

**CONNECTION: A – B**

**STANDARD: 2.3 – 2.6 k $\Omega$  (20°C/68°F)**

**Is the resistance within 2.3 – 2.6 k $\Omega$ ?**

**YES** – Replace the ECM with a new one and recheck.

**NO** – Faulty ECT sensor

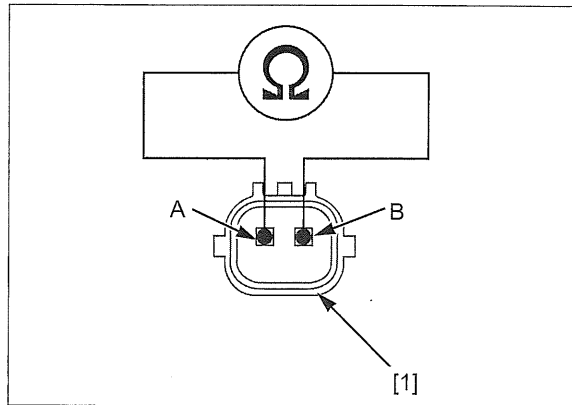

**4. ECT Sensor Output Line Short Circuit Inspection**

Turn the ignition switch OFF.  
Disconnect the ECM 21P (Gray) connector.

Check for continuity between the ECT sensor 2P (Black) connector [1] terminal of the wire harness side and ground with ECM 21P (Gray) connector disconnected.

**CONNECTION: Pink/white – ground**

**STANDARD: No continuity**

**Is there continuity?**

**YES** – Short circuit in the Pink/white wire

**NO** – Replace the ECM with a known good one and recheck.

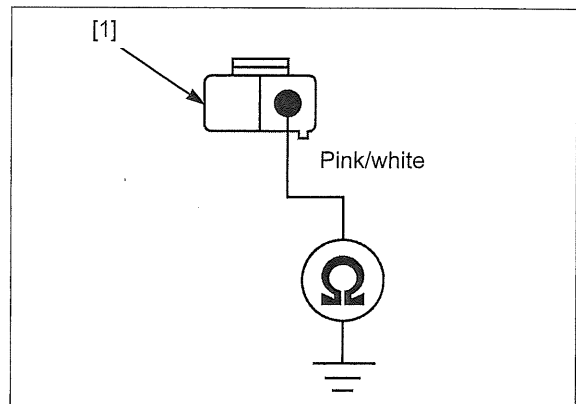

## DTC 7-2 (ECT SENSOR HIGH VOLTAGE)

- Before starting the inspection, check for loose or poor contact on the ECT sensor 2P (Black) connector and recheck the DTC.

### 1. ECT Sensor System Inspection

Turn the ignition switch ON and engine stop switch "O".

Check the ECT sensor with the MCS tester.

**Is about 5 V indicated?**

**YES** – GO TO STEP 2.

- NO** –
- Intermittent failure
  - Loose or poor contact on the ECT sensor 2P (Black) connector

### 2. ECT Sensor Inspection

Turn the ignition switch OFF.

Disconnect the ECT sensor 2P (Black) connector.

Connect the ECT sensor 2P (Black) connector [1] terminals of the wire harness side with a jumper wire [2].

**CONNECTION: Pink/white – Green/orange**

Turn the ignition switch ON.

Check the ECT sensor with the MCS tester.

**Is about 0 V indicated?**

**YES** – Inspect the ECT sensor (page 4-52).

**NO** – GO TO STEP 3.

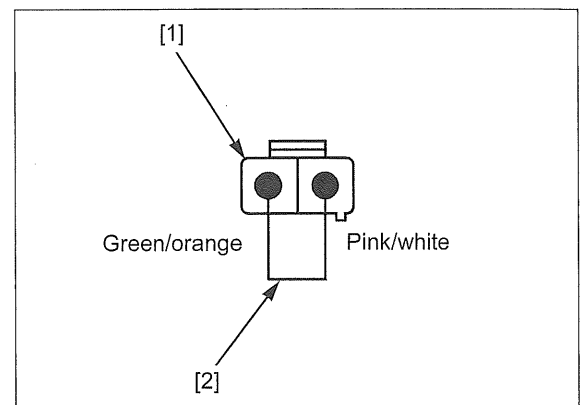

### 3. ECT Sensor Output/ground Line Inspection

Turn the ignition switch OFF.

Disconnect the jumper wire.

Disconnect the ECM 21P (Gray) connector.

Check the continuity between the ECT sensor 2P (Black) connector [1] of the wire harness side and ECM 21P (Gray) connector [2].

**CONNECTION:**

**Pink/white – B19 (Pink/white)**

**Green/orange – B7 (Green/orange)**

**STANDARD: Continuity**

**TOOL:**

Test probe, 2 pack

07ZAJ-RDJA110

**Is there continuity?**

**YES** – Replace the ECM with new one and recheck.

- NO** –
- Open circuit in the Pink/white wire
  - Open circuit in the Green/orange wire

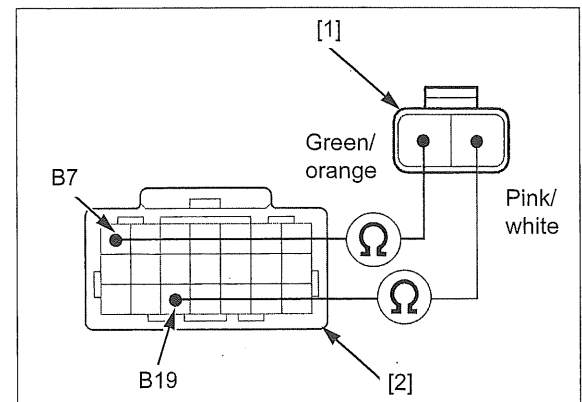

**DTC 8-1 (TP SENSOR LOW VOLTAGE)**

- Before starting the inspection, check for loose or poor contact on the sensor unit 5P (Black) connector and recheck the DTC.

**1. TP Sensor System Inspection**

Turn the ignition switch ON and engine stop switch "O".

Check the TP sensor with the MCS tester when the throttle fully closed.

**Is about 0 V indicated?**

**YES** – GO TO STEP 3.

**NO** – GO TO STEP 2.

**2. TP Sensor Inspection**

Check that TP sensor voltage is increasing uninterrupted when moving the throttle from fully closed to fully opened using the data list menu of the MCS tester.

**Does the voltage increase continuously?**

**YES** – • Intermittent failure  
• Loose or poor contact on the sensor unit 5P (Black) connector

**NO** – Replace the sensor unit with a new one and recheck (Faulty TP sensor).

**3. TP Sensor Resistance Inspection**

Turn the ignition switch OFF.  
Disconnect the sensor unit 5P (Black) connector.

Measure the resistance at the 5P connector [1] of the sensor unit side.

**CONNECTION: B – C**

**STANDARD: 0.5 – 0.7 kΩ (20°C/68°F)**

**Is the resistance within 0.5 – 0.7 kΩ?**

**YES** – GO TO STEP 4.

**NO** – Replace the sensor unit with a new one and recheck (Faulty TP sensor)

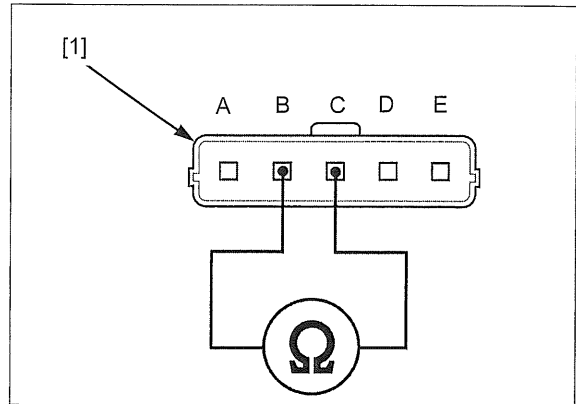

**4. TP Sensor Output Line Open Circuit Inspection**

Disconnect the ECM 21P (Gray) connector.

Check for continuity between the ECM 21P (Gray) connector [1] of the wire harness side and sensor unit 5P (Black) connector [2] of the wire harness side.

**CONNECTION: Yellow/blue – B4 (Yellow/blue)**

**STANDARD: Continuity**

**TOOL:**

**Test probe, 2 pack 07ZAJ-RDJA110**

**Is there continuity?**

**YES** – GO TO STEP 5.

**NO** – Open circuit in the Yellow/blue wire

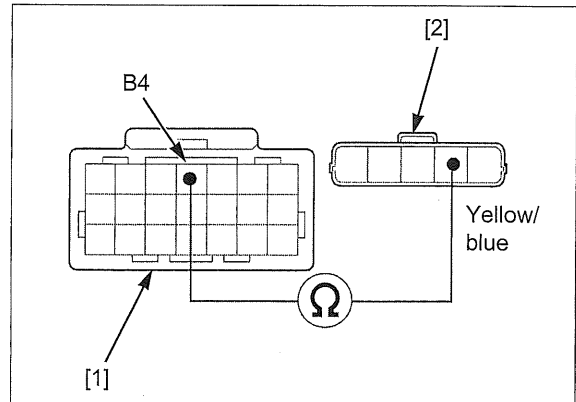

**5. TP Sensor Output Line Short Circuit Inspection**

Check for continuity between the sensor unit 5P (Black) connector [1] terminal of the wire harness side and ground with ECM 21P (Gray) connector disconnected.

**CONNECTION:** Yellow/blue – ground  
**STANDARD:** No continuity

*Is there continuity?*

- YES** – Short circuit in the Yellow/blue wire
- NO** – GO TO STEP 6.

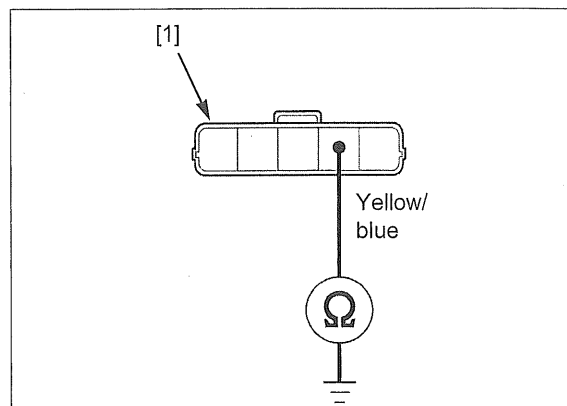

**6. TP Sensor Input Voltage Inspection**

Connect the ECM 21P (Gray) connector.

Turn the ignition switch ON.

Measure the voltage between the sensor unit 5P (Black) connector [1] of the wire harness side and ground.

**CONNECTION:** Yellow/orange (+) – Ground (-)  
**STANDARD:** 4.75 – 5.25 V

*Is the voltage within 4.75 – 5.25 V?*

- YES** – Replace the sensor unit with a new one and recheck (Faulty TP sensor).
- NO** – GO TO STEP 7.

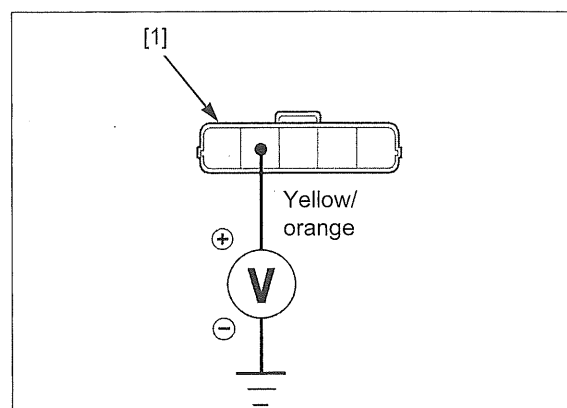

**7. TP Sensor Input Line Open Circuit Inspection**

Turn the ignition switch OFF.

Disconnect the ECM 21P (Gray) connector.

Check for continuity between the sensor unit 5P (Black) connector [1] and ECM 21P (Gray) connector [2] of the wire harness side.

**CONNECTION:** Yellow/orange – B21 (Yellow/orange)  
**STANDARD:** Continuity

*Is there continuity?*

- YES** – Replace the ECM with a new one and recheck.
- NO** – Open circuit in the Yellow/orange wire.

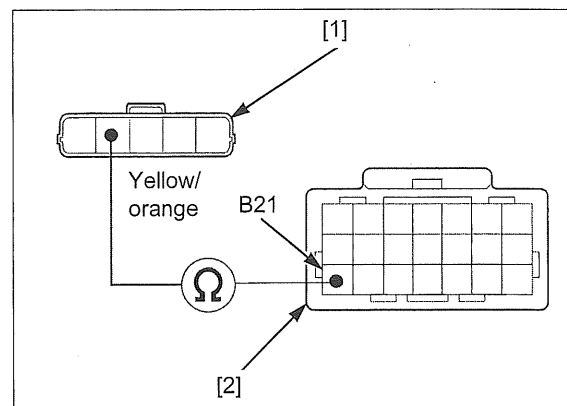

**DTC 8-2 (TP SENSOR HIGH VOLTAGE)**

**1. TP Sensor System Inspection**

Turn the ignition switch ON and engine stop switch "O".

Check the TP sensor with the MCS tester with the throttle fully closed.

**Is about 5 V indicated?**

**YES** – GO TO STEP 3.

**NO** – GO TO STEP 2.

**2. TP Sensor Inspection**

Check that TP sensor voltage is increasing uninterrupted when moving the throttle from fully closed to fully opened using the data list menu of the MCS tester.

**Does the voltage increase continuously?**

**YES** – Intermittent failure

**NO** – Replace the sensor unit with a new one and recheck (Faulty TP sensor).

**3. TP Sensor Resistance Inspection**

Turn the ignition switch OFF.  
Disconnect the sensor unit 5P (Black) connector.

Measure the resistance at the 5P connector [1] of the sensor unit side.

**CONNECTION: B – C**

**STANDARD: 0.5 – 0.7 kΩ (20°C/68°F)**

**Is the resistance within 0.5 – 0.7 kΩ?**

**YES** – GO TO STEP 4.

**NO** – Replace the sensor unit with a new one and recheck (Faulty TP sensor).

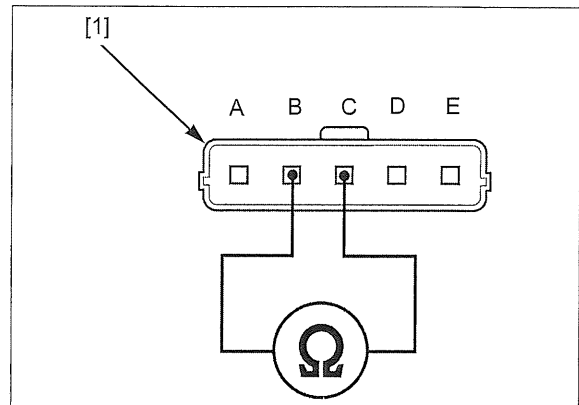

**4. TP Sensor Ground line Inspection**

Turn the ignition switch ON.  
Measure the voltage between the sensor unit 5P (Black) connector [1] of the wire harness side.

**CONNECTION: Yellow/orange (+) – Green/orange(-)**

**STANDARD: 4.75 – 5.25 V**

**Is the voltage within 4.75 – 5.25 V?**

**YES** – Replace the ECM with a new one and recheck.

**NO** – Open circuit in the Green/orange wire

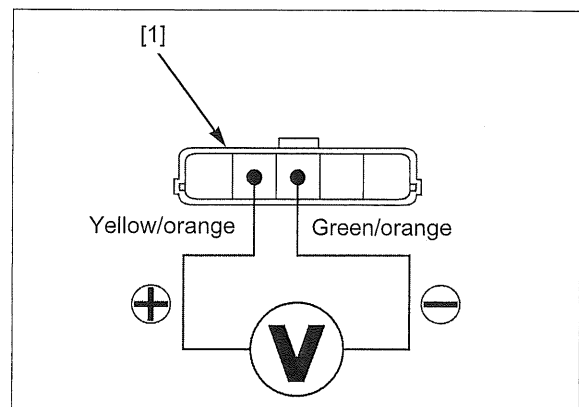



**DTC 9-1 (IAT SENSOR LOW VOLTAGE)****1. IAT Sensor System Inspection**

Turn the ignition switch ON and engine stop switch "O".

Check the IAT sensor with the MCS tester.

**Is about 0 V indicated?**

**YES** – GO TO STEP 2.

**NO** – Intermittent failure

**2. IAT Sensor Inspection**

Turn the ignition switch OFF.

Disconnect the sensor unit 5P (Black) connector.

Turn the ignition switch ON.

Check the IAT sensor with the MCS tester.

**Is about 0 V indicated?**

**YES** – GO TO STEP 3.

**NO** – Replace the sensor unit with a new one and recheck (Faulty IAT sensor).

**3. IAT Sensor Output Line Short Circuit Inspection**

Turn the ignition switch OFF.

Disconnect the ECM 21P (Gray) connector.

Check for continuity between the ECM 21P (Gray) connector [1] of the wire harness side and ground with sensor unit 5P (Black) connector disconnected.

**CONNECTION: B12 (White/blue) – Ground**

**STANDARD: No continuity**

**TOOL:**

Test probe, 2 pack                      07ZAJ-RDJA110

**Is there continuity?**

**YES** – Short circuit in the White/blue wire

**NO** – Replace the ECM with a new one and recheck.

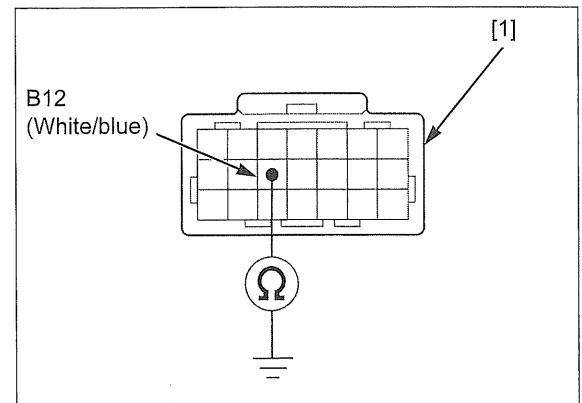

**DTC 9-2 (IAT SENSOR HIGH VOLTAGE)**

- Before starting the inspection, check for loose or poor contact on the sensor unit 5P (Black) connector and recheck the DTC.

**1. IAT Sensor System Inspection**

Turn the ignition switch ON and engine stop switch "O".  
Check the IAT sensor with the MCS tester.

**Is about 5 V indicated?**

**YES** – GO TO STEP 2.

- NO** –
- Intermittent failure
  - Loose or poor contact on the sensor unit 5P (Black) connector

**2. IAT Sensor Output Voltage Inspection**

Turn the ignition switch OFF.  
Disconnect the sensor unit 5P (Black) connector.  
Connect the sensor unit 5P (Black) connector [1] terminals of the wire harness side with a jumper wire [2].

**CONNECTION: White/blue – Green/orange**

Turn the ignition switch ON.  
Check the IAT sensor with the MCS tester.

**Is about 0 V indicated?**

**YES** – Replace the sensor unit with a new one and recheck (Faulty IAT sensor).

**NO** – GO TO STEP 3.

**3. IAT Sensor Output Line Open Circuit Inspection**

Turn the ignition switch OFF.  
Disconnect the jumper wire.  
Disconnect the ECM 21P (Gray) connector.

Check for continuity between the sensor unit 5P (Black) connector [1] of the wire harness side and ECM 21P (Gray) connector [2] of the wire harness side.

**CONNECTION: White/blue – B12 (White/blue)**

**STANDARD: Continuity**

**TOOL:**

Test probe, 2 pack                      07ZAJ-RDJA110

**Is there continuity?**

**YES** – GO TO STEP 4.

**NO** – Open circuit in the White/blue wire

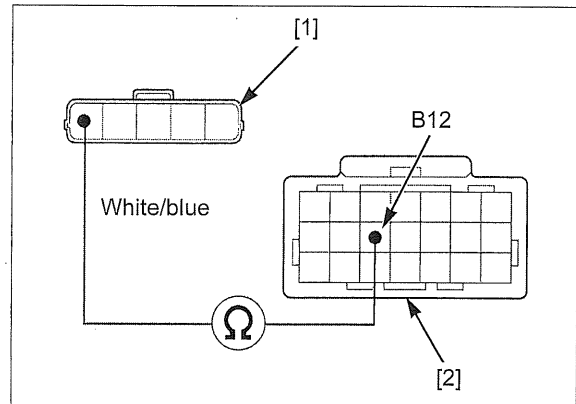
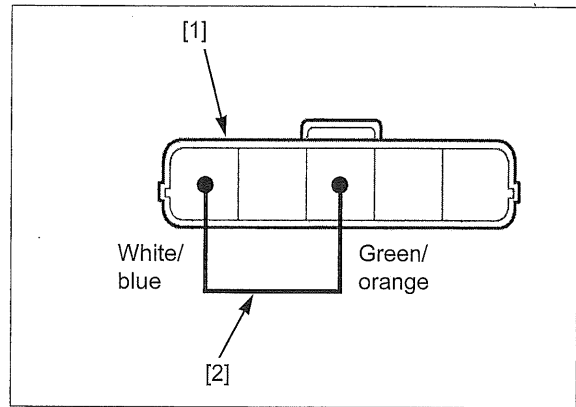

**4. IAT Sensor Ground line Inspection**

Turn the ignition switch OFF.  
Disconnect the ECM 21P (Gray) connector.

Check for continuity between the sensor unit 5P (Black) connector [1] of the wire harness side and ECM 21P (Gray) connector [2] of the wire harness side.

**CONNECTION:**

Green/orange – B7 (Green/orange)

**STANDARD: Continuity**

**TOOL:**

Test probe, 2 pack                      07ZAJ-RDJA110

**Is there continuity?**

**YES** – Replace the ECM with a new one and recheck.

**NO** – Open circuit in the Green/orange wire

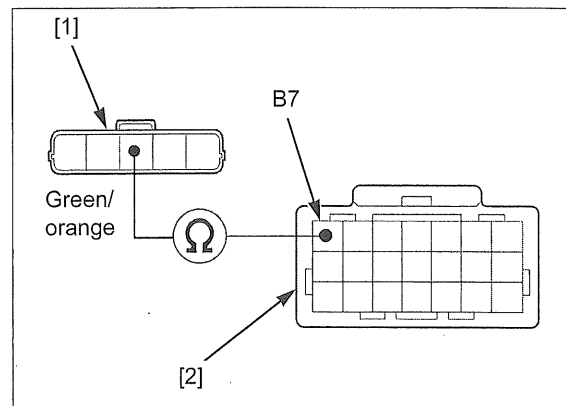

**DTC 12-1 (FUEL INJECTOR)**

- Before starting the inspection, check for loose or poor contact on the fuel injector 2P (Black) connector and recheck the DTC.

**1. Fuel injector System Inspection**

Clear the DTC's (page 4-12).  
Turn the ignition switch ON and engine stop switch "O", then start the engine and check the fuel injector with the MCS tester.

**Is the DTC 12-1 indicated?**

**YES** – GO TO STEP 2.

**NO** – • Intermittent failure  
• Loose or poor contact on the fuel injector 2P (Black) connector

**2. Fuel injector Input Voltage Inspection**

Turn the ignition switch OFF.  
Disconnect the fuel injector 2P (Black) connector.  
Turn the ignition switch ON and engine stop switch "O".  
Measure the voltage between the fuel injector 2P (Black) connector [1] of the wire harness side and ground.

**CONNECTION: Black/white (+) – Ground (-)**

**Does the battery voltage exist?**

**YES** – GO TO STEP 3.

**NO** – Open circuit in the Black/white wire

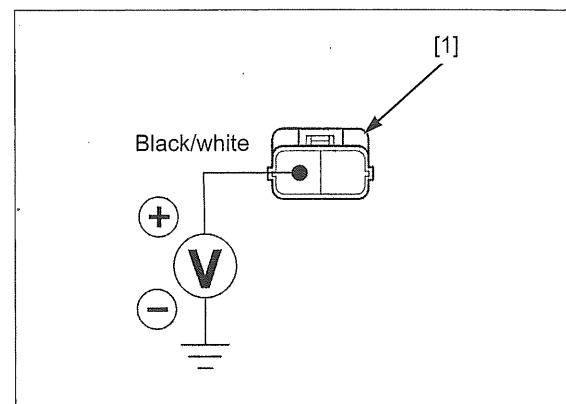

**3. Fuel injector Resistance Inspection**

Turn the ignition switch OFF.  
 Measure the resistance at the 2P connector [1] terminals of the fuel injector side.

**STANDARD: 11 – 13  $\Omega$  (20 °C/68 °F)**

**Is the resistance within 11 – 13  $\Omega$  (20°C/68°F)?**

**YES** – GO TO STEP 4.

**NO** – Faulty fuel injector

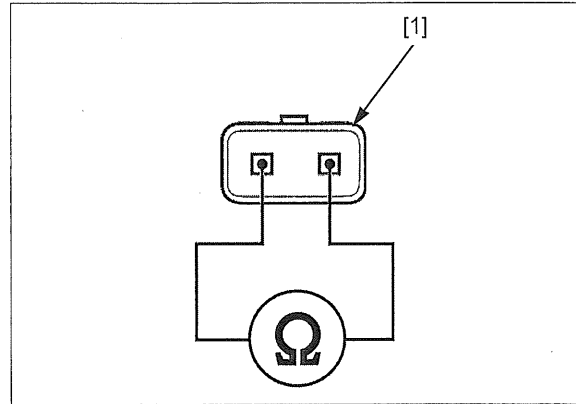

**4. Fuel injector Signal Line Open Circuit Inspection**

Disconnect the ECM 21P (Black) connector.

Check the continuity between the fuel injector 2P (Black) connector [1] of the wire harness side and ECM 21P (Black) connector [2] of the wire harness side.

**CONNECTION: Pink/Blue – A14 (Pink/Blue)**

**STANDARD: Continuity**

**TOOL:**

Test probe, 2 pack                      07ZAJ-RDJA110

**Is there continuity?**

**YES** – GO TO STEP 5.

**NO** – Open circuit in the Pink/blue wire

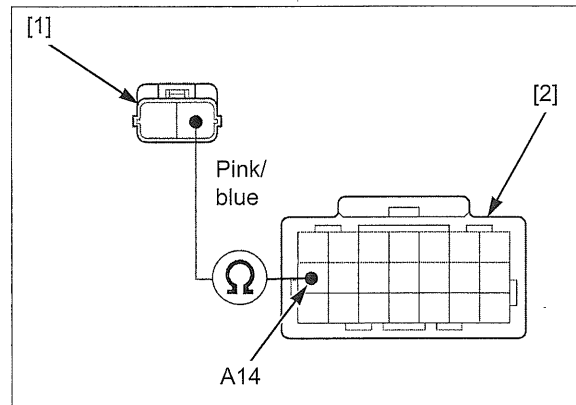

**5. Fuel injector Signal Line Short Circuit Inspection**

Check for continuity between the fuel injector 2P (Black) connector [1] and ground with the ECM 21P (Black) connector disconnected.

**CONNECTION: Pink/blue – Ground**

**STANDARD: No continuity**

**Is there continuity?**

**YES** – Short circuit in the Pink/blue wire

**NO** – Replace the ECM with a new one and recheck.

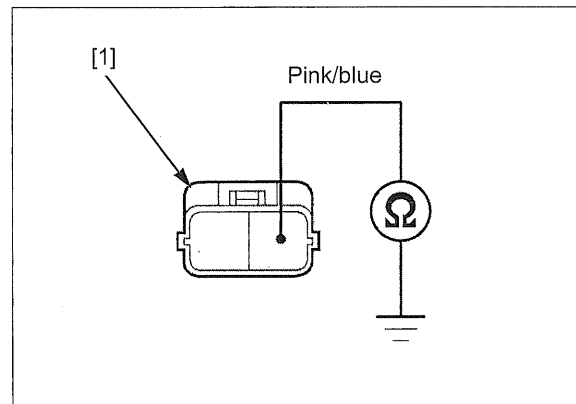

**DTC 21-1 (O<sub>2</sub> SENSOR)**

- Before starting the inspection, check for loose or poor contact on the O<sub>2</sub> sensor cap connector and recheck the DTC.

**1. O<sub>2</sub> Sensor Line Open Circuit Inspection**

Turn the ignition switch OFF.

Disconnect the following:

- ECM 21P (Gray) connector
- O<sub>2</sub> sensor cap (page 4-53)

Check the continuity between the ECM 21P (Gray) connector [1] of the wire harness side and O<sub>2</sub> sensor cap terminal [2].

**CONNECTION:**

O<sub>2</sub> sensor cap terminal – B5 (Black/orange)

**STANDARD: Continuity**

**TOOL:**

Test probe, 2 pack                      07ZAJ-RDJA110

**Is there continuity?**

**YES** – GO TO STEP 2.

**NO** – Open circuit in the Black or Black/orange wire

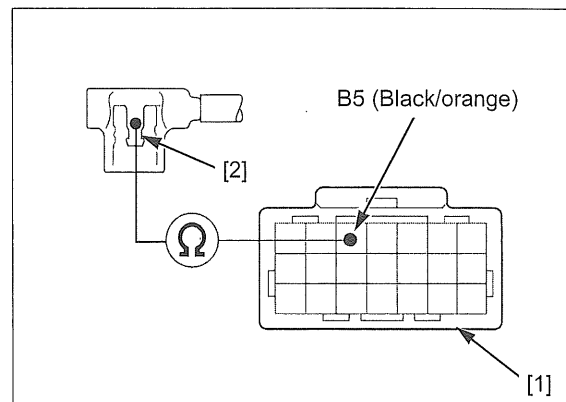
**2. O<sub>2</sub> Sensor Line Short Circuit Inspection**

With the ECM 21P (Gray) connector disconnected, check for continuity between the O<sub>2</sub> sensor cap terminal [1] and ground.

**CONNECTION: O<sub>2</sub> sensor cap terminal – Ground**

**STANDARD: No continuity**

**TOOL:**

Test probe, 2 pack                      07ZAJ-RDJA110

**Is there continuity?**

**YES** – Short circuit in the Black or Black/orange wire

**NO** – GO TO STEP 3.

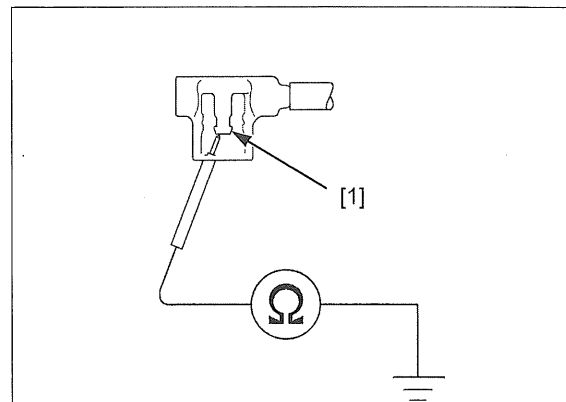
**3. O<sub>2</sub> Sensor Inspection**

Replace the O<sub>2</sub> sensor with a known good one (page 4-53).

Clear the DTC (page 4-12).

Start the engine and warm the engine up to coolant temperature is 80 °C (176 °C).

Test-ride the scooter and check the O<sub>2</sub> sensor with the MCS tester.

**Is the DTC 21-1 indicated?**

**YES** – Replace the ECM with a new one and recheck.

**NO** – Faulty original O<sub>2</sub> sensor

**DTC 29-1 (IACV)**

- Before starting the inspection, check for loose or poor contact on the IACV 4P (Black) connector and recheck the DTC.

**1. Recheck DTC**

Clear the DTC's (page 4-12).  
Start the engine and recheck the DTC.

**Is the DTC 29-1 indicated?**

**YES** – GO TO STEP 2.

- NO** –
- Intermittent failure
  - Loose or poor contact on the IACV 4P (Black) connector

**2. IACV Short Circuit Inspection**

Turn the ignition switch OFF.  
Disconnect the IACV 4P (Black) connector.

Check for continuity between the IACV 4P (Black) connector [1] of the wire harness side and ground.

**CONNECTION:** Light green/red – Ground  
Brown/red – Ground  
Gray/red – Ground  
Black/red – Ground

**STANDARD:** No continuity

**Are there continuities?**

- YES** –
- Short circuit in the Light green/red or Brown/red wire
  - Short circuit in the Gray/red or Black/red wire

**NO** – GO TO STEP 3.

**3. IACV Circuit Continuity Inspection**

Disconnect the ECM 21P (Black) connector.

Check the continuity between the ECM 21P (Black) connector [1] terminals and IACV 4P (Black) connector [2] terminals of the wire harness side.

**CONNECTION:**  
Light green/red – A17 (Light green/red)  
Brown/red – A10 (Brown/red)  
Gray/red – A3 (Gray/red)  
Black/red – A11 (Black/red)

**STANDARD:** Continuity

**TOOL:**

Test probe, 2 pack                      07ZAJ-RDJA110

**Are there continuities?**

**YES** – GO TO STEP 4.

- NO** –
- Open circuit in the Light green/red or Brown/red wire
  - Open circuit in the Gray/red or Black/red wire

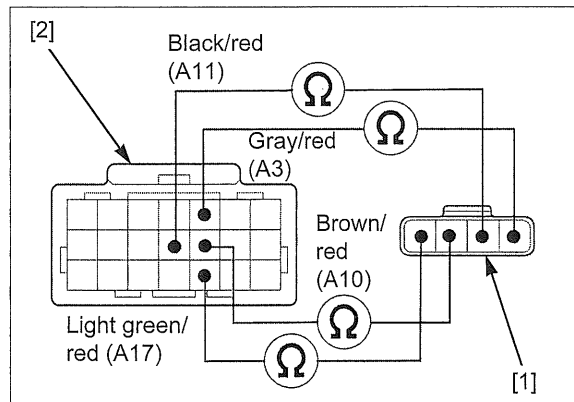
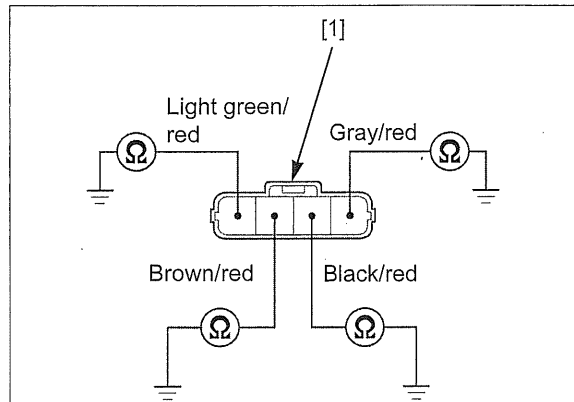

**4. IACV Resistance Inspection**

Measure the resistance at the IACV 4P (Black) connector [1] terminals of the IACV side.

**CONNECTION: A – D  
B – C**

**STANDARD: 110 – 150 Ω (20 °C/68 °F)**

**Is the resistance within 110 – 150 Ω (20°C/68°F)?**

**YES** – GO TO STEP 5.

**NO** – Faulty IACV. Replace the IACV with a new one and recheck.

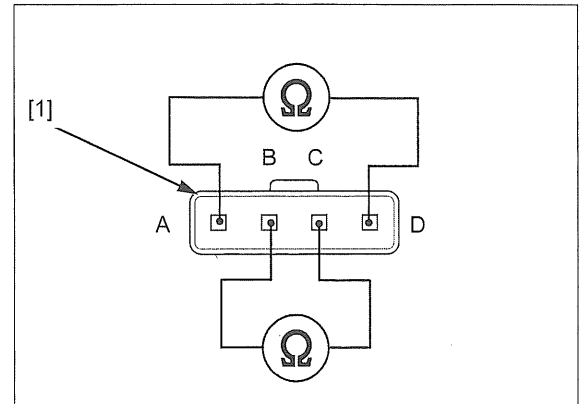

**5. IACV Short Circuit Inspection**

Check for continuity at the IACV 4P (Black) connector [1] terminals of the IACV side.

**CONNECTION: A – B  
C – D**

**STANDARD: No continuity**

**Is there continuity?**

**YES** – Faulty IACV. Replace the IACV with a new one and recheck.

**NO** – Replace the ECM with new one and recheck.

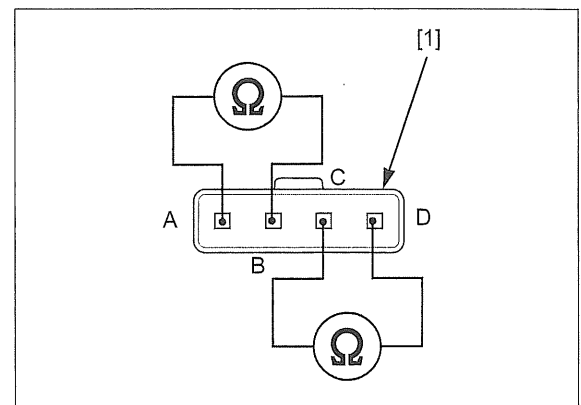

**DTC 52-1 (CKP SENSOR)**

- Before starting the inspection, check for loose or poor contact on the CKP sensor 6P (Black) connector and ECM 3P (Black) connector and recheck the DTC.

**1. Recheck DTC**

Clear the DTC's (page 4-12).  
Start the engine and recheck the DTC.

**Is the DTC 52-1 indicated?**

**YES** – GO TO STEP 2.

- NO** –
- Intermittent failure
  - Loose or poor contact on the CKP sensor 6P (Black) connector
  - Loose or poor contact on the ECM 3P (Black) connector

**2. CKP Sensor Circuit Inspection**

Turn the ignition switch OFF.  
Disconnect the CKP sensor 6P (Black) connector.  
Check the connector for loose contacts or corroded terminals.

Measure the voltage at the CKP sensor 6P (Black) connector [1] of the wire harness side.

- CONNECTION:** White/red (+) – Ground (–)  
White/blue (+) – Ground (–)  
White/black (+) – Ground (–)  
Blue/yellow (+) – Ground (–)

**STANDARD:** 5 – 10 V

- CONNECTION:** Brown/black (+) – Blue/green (–)  
**STANDARD:** Battery voltage

**Does the standard voltage exist?**

**YES** – GO TO STEP 3.

- NO** – Open circuit in wire harness between the ECM and CKP sensor connector

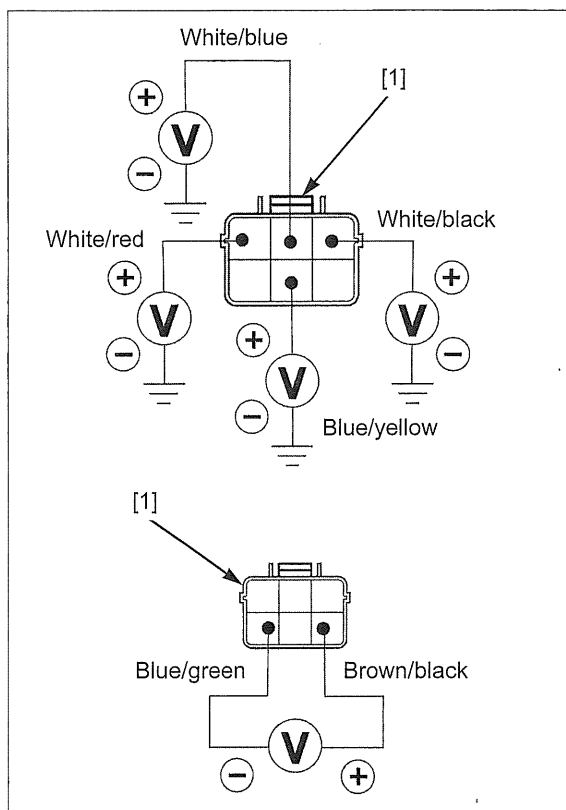

**3. CKP Sensor Inspection**

Replace the CKP sensor with a known good one (page 14-4).

Clear the DTC's (page 4-12).  
Start the engine and warm it up.  
Test-ride the scooter and recheck the DTC.

**Is the DTC 52-1 indicated?**

**YES** – Replace the ECM with a known good one and recheck.

**NO** – Faulty original CKP sensor



# SENSOR UNIT POWER LINE INSPECTION (AFTER '13 MODEL)

## BEFORE DTC TROUBLESHOOTING

**NOTE:**

- When the DTC displays 1-1, 1-2, 8-1, 8-2, 9-1, or 9-2, check the following before DTC troubleshooting.
- Before starting the inspection, check for loose or poor contact on the sensor unit 5P (Black) connector and ECM 33P (Black) connector.

### 1. Sensor Unit Power Input Voltage Inspection

Turn the ignition switch OFF.

Disconnect the sensor unit 5P (Black) connector (page 7-15).

Turn the ignition switch ON.

Measure the voltage at the sensor unit 5P (Black) connector [1] of the wire harness side.

**Connection: Yellow/white (+) – Green/orange (-)**  
**Standard: 4.75 – 5.25 V**

**Is the voltage within 4.75 – 5.25 V?**

**YES** – Turn the ignition switch OFF. Connect the sensor unit 5P (Black) connector and start the DTC troubleshooting (page 4-34).

**NO** – GO TO STEP 2.

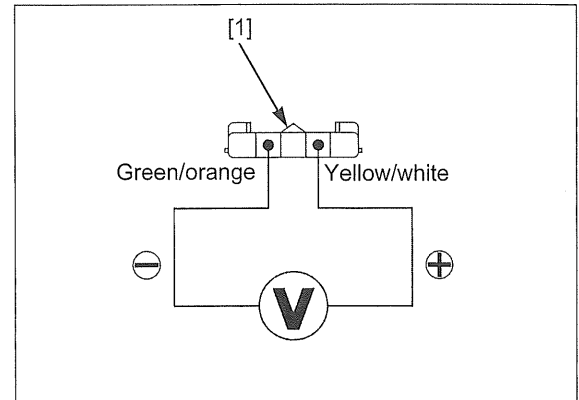

### 2. Sensor Unit Input Voltage Line Short Circuit Inspection

Turn the ignition switch OFF.

Check for continuity between the sensor unit 5P (Black) connector [1] of the wire harness side and ground.

**Connection: Yellow/white – Ground**

**Is there continuity?**

**YES** – Short circuit in the Yellow/white wire

**NO** – GO TO STEP 3.

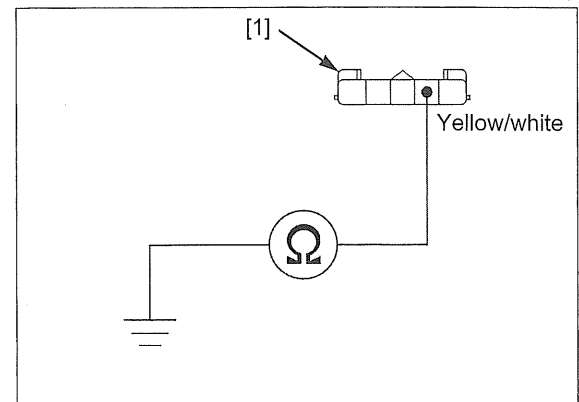

### 3. Sensor Unit Power Line Open Circuit Inspection

Disconnect the ECM 33P (Black) connector (page 4-49).

Check for continuity between the sensor unit 5P (Black) connector [1] and ECM 33P (Black) connector [2] of the wire harness side.

**Connection: A5 – Green/orange**  
**A6 – Yellow/white**

**TOOL:**

**Test probe, 2 pack 07ZAJ-RDJA110**

**Is there continuity?**

**YES** – Replace the ECM with a known good one and recheck.

**NO** – • Open circuit in the Yellow/white wire  
• Open circuit in the Green/orange wire

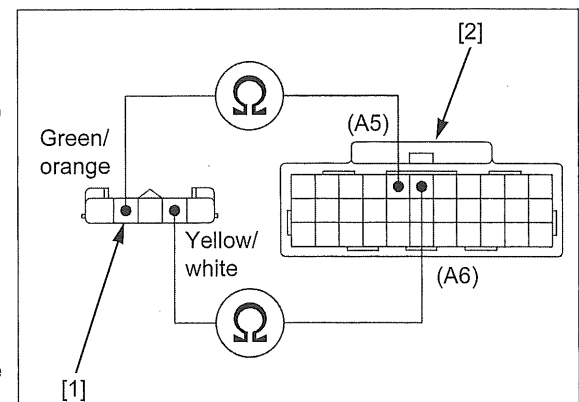

# DTC TROUBLESHOOTING (AFTER '13 MODEL)

## DTC 1-1 (MAP SENSOR LOW VOLTAGE)

### 1. MAP Sensor System Inspection

Turn the ignition switch ON.  
Check the MAP sensor with the MCS.

**Is about 0 V indicated?**

**YES** – GO TO STEP 2.

**NO** – Intermittent failure

### 2. Sensor Unit Power Line Inspection

Check the sensor unit power line inspection (page 4-33).

**Is the sensor unit power line normal?**

**YES** – GO TO STEP 3.

**NO** – Replace or repair the abnormal circuit.

### 3. MAP Sensor Output Voltage Inspection

Turn the ignition switch OFF.

Disconnect the sensor unit 5P (Black) connector (page 7-15).

Turn the ignition switch ON.

Measure the voltage at the sensor unit 5P (Black) connector [1] of the wire harness side.

**Connection: Yellow/red (+) – Green/orange (-)**

**Standard: 4.75 – 5.25 V**

**Is the voltage within 4.75 – 5.25 V?**

**YES** – GO TO STEP 5.

**NO** – GO TO STEP 4.

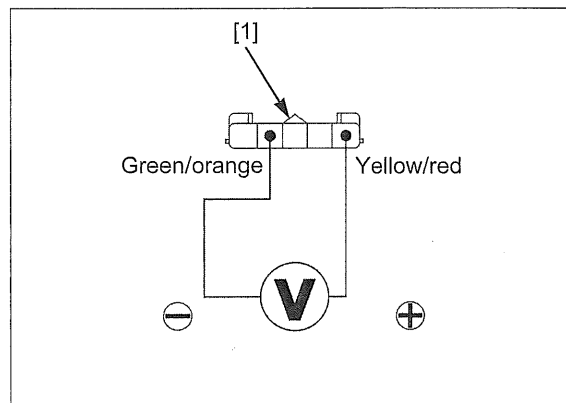

### 4. MAP Sensor Output Line Short Circuit Inspection

Turn the ignition switch OFF.

Check for continuity between the sensor unit 5P (Black) connector [1] of the wire harness side and ground.

**Connection: Yellow/red – ground**

**Is there continuity?**

**YES** – Short circuit in the Yellow/red wire

**NO** – GO TO STEP 5.

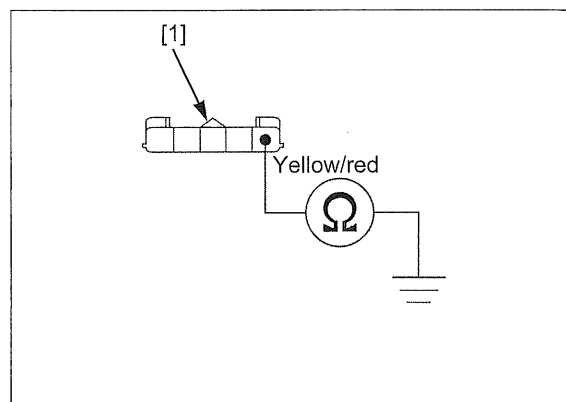

**5. MAP Sensor Inspection**

Replace the sensor unit with a known good one (page 7-16).  
Erase the DTC's (page 4-12).

Turn the ignition switch OFF.

Connect the sensor unit 5P (Black) connector.

Turn the ignition switch.

Check the MAP sensor with the MCS.

**Is DTC 1-1 indicated?**

**YES** – Replace the ECM with a known good one and recheck.

**NO** – Faulty original sensor unit (MAP sensor)

**DTC 1-2 (MAP SENSOR HIGH VOLTAGE)**

**1. MAP Sensor System Inspection 1**

Turn the ignition switch ON.

Check the MAP sensor with the MCS.

**Is about 5 V indicated?**

**YES** – GO TO STEP 2.

**NO** – • Intermittent failure  
• Loose or poor contact on the sensor unit 5P (Black) connector

**2. Sensor Unit Power Line Inspection**

Check the sensor unit power line inspection (page 4-33).

**Is the sensor unit power line normal?**

**YES** – GO TO STEP 3.

**NO** – Replace or repair the abnormal circuit.

**3. MAP Sensor System Inspection 2**

Turn the ignition switch OFF.

Disconnect the sensor unit 5P (Black) connector (page 7-15).

Connect the sensor unit 5P (Black) connector [1] terminals at the wire harness side with a jumper wire [2].

**Connection: Yellow/red – Green/orange**

Turn the ignition switch ON.

Check the MAP sensor with the MCS.

**Is about 0 V indicated?**

**YES** – Faulty sensor unit (MAP sensor)

**NO** – GO TO STEP 4.

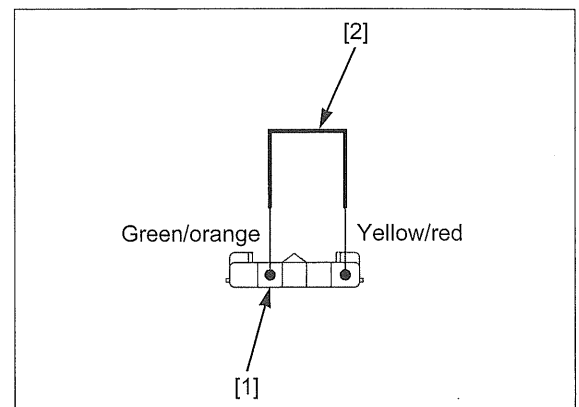

**4. MAP Sensor Output Line Open Circuit Inspection**

Turn the ignition switch OFF.

Remove the jumper wire.  
Disconnect the ECM 33P (Black) connector (page 4-49).

Check the continuity between the ECM 33P (Black) connector [1] and sensor unit 5P (Black) connector [2] of the wire harness side.

**Connection: A19 – Yellow/red**

**TOOL:**

**Test probe, 2 pack                      07ZAJ-RDJA110**

**Is there continuity?**

**YES** – Replace the ECM with a known good one and recheck.

**NO** – Open circuit in the Yellow/red wire

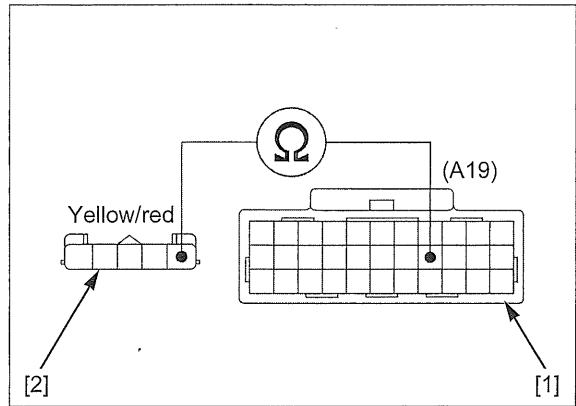

**DTC 7-1 (ECT SENSOR LOW VOLTAGE)**

**1. ECT Sensor System Inspection**

Turn the ignition switch ON.

Check the ECT sensor with the MCS.

**Is about 0 V indicated?**

**YES** – GO TO STEP 2.

**NO** – Intermittent failure

**2. ECT Sensor Inspection**

Turn the ignition switch OFF.

Disconnect the ECT sensor 2P (Black) connector (page 4-52).

Turn the ignition switch ON.

Check the ECT sensor with the MCS.

**Is about 0 V indicated?**

**YES** – GO TO STEP 3.

**NO** – Faulty ECT sensor

**3. ECT Sensor Output Line Short Circuit Inspection**

Check for continuity between the ECT sensor 2P (Black) connector [1] at the wire harness side and ground.

**Connection: Pink/white – Ground**

**Is there continuity?**

**YES** – Short circuit in the Pink/white wire

**NO** – Replace the ECM with a known good one and recheck.

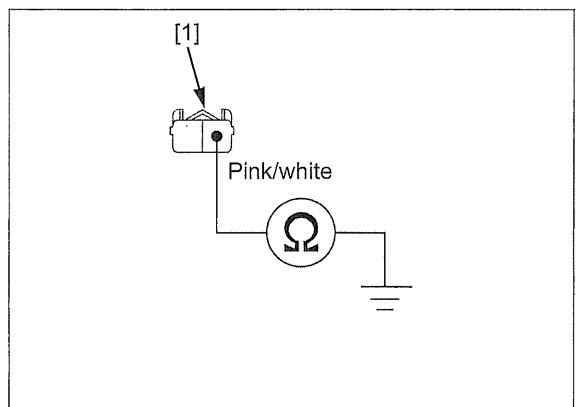

## DTC 7-2 (ECT SENSOR HIGH VOLTAGE)

**NOTE:**

Before starting the inspection, check for loose or poor contact on the ECT sensor 2P (Black) connector and ECM 33P (Black) connector, and recheck the DTC.

### 1. ECT Sensor System Inspection

Turn the ignition switch ON.

Check the ECT sensor with the MCS.

**Is about 5 V indicated?**

**YES** – GO TO STEP 2.

**NO** – Intermittent failure

### 2. ECT Sensor Inspection

Turn the ignition switch OFF.

Disconnect the ECT sensor 2P (Black) connector (page 4-52).

Connect the ECT sensor 2P (Black) connector [1] terminals at the wire harness side with a jumper wire [2].

**Connection: Pink/white – Green/orange**

Turn the ignition switch ON.

Check the ECT sensor with the MCS.

**Is about 0 V indicated?**

**YES** – Replace the ECT sensor with a known good one and recheck.

**NO** – GO TO STEP 3.

### 3. ECT Sensor Open Circuit Inspection

Turn the ignition switch OFF.

Remove the jumper wire.

Disconnect the ECM 33P (Black) connector (page 4-49).

Check for continuity between the ECM 33P (Black) connector [1] and ECT sensor 2P (Black) connector [2] of the wire harness side.

**TOOL:**

**Test probe, 2 pack 07ZAJ-RDJA110**

**Connection: A18 – Pink/white**

**A5 – Green/orange**

**Are there continuities?**

**YES** – Replace the ECM with a known good one and recheck.

**NO** – • Open circuit in the Pink/white wire  
• Open circuit in the Green/orange wire

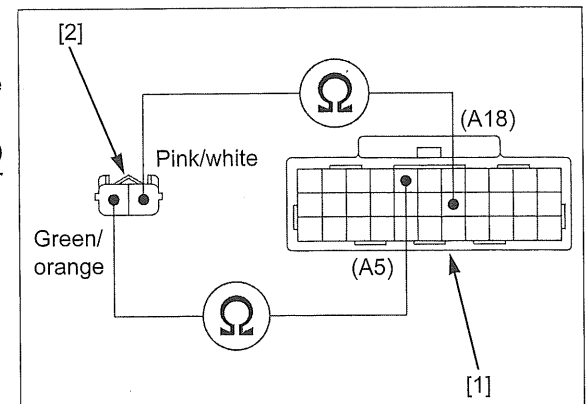
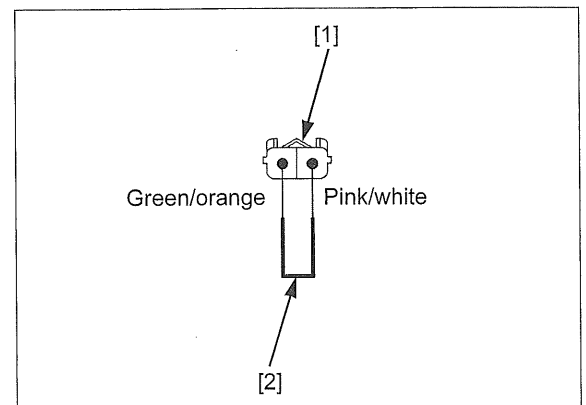

**DTC 8-1 (TP SENSOR LOW VOLTAGE)**

**NOTE:**

Before starting the inspection, check for loose or poor contact on the sensor unit 5P (Black) connector and recheck the DTC.

**1. TP Sensor System Inspection**

Turn the ignition switch ON.

Check the TP sensor with the MCS with the throttle fully closed.

**Is about 0 V indicated?**

- YES** – • Intermittent failure  
 • Loose or poor contact on the sensor unit 5P (Black) connector

**NO** – GO TO STEP 2.

**2. Sensor Unit Power Line Inspection**

Check the sensor unit power line inspection (page 4-33).

**Is the sensor unit power line normal?**

**YES** – GO TO STEP 3.

**NO** – Replace or repair the abnormal circuit.

**3. TP Sensor Output Line Short Circuit Inspection**

Turn the ignition switch OFF.

Disconnect the sensor unit 5P (Black) connector (page 7-15).

Check for continuity between the sensor unit 5P (Black) connector [1] of the wire harness side and ground.

**Connection: Yellow/blue – Ground**

**Is there continuity?**

**YES** – Short circuit in the Yellow/blue wire

**NO** – GO TO STEP 4.

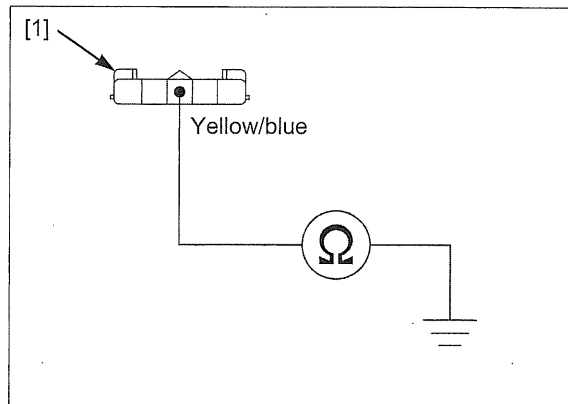

**4. TP Sensor Output Line Open Circuit Inspection**

Disconnect the ECM 33P (Black) connector (page 4-49).

Check for continuity between the ECM 33P (Black) connector [1] and sensor unit 5P (Black) connector [2] of the wire harness side.

**Connection: A8 – Yellow/blue**

**TOOL:**

**Test probe, 2 pack**                      **07ZAJ-RDJA110**

**Is there continuity?**

**YES** – GO TO STEP 5.

**NO** – Open circuit in the Yellow/blue wire

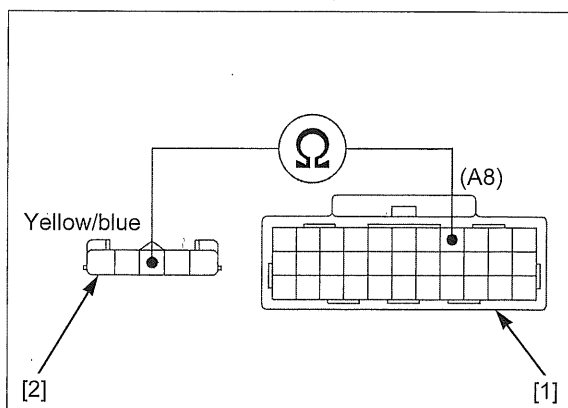

**5. TP Sensor Inspection**

Replace the sensor unit with a known good one (page 7-16).

Connect the sensor unit 5P (Black) and ECM 33P (Black) connectors.

Erase the DTC's (page 4-12).

Turn the ignition switch ON.

Check the TP sensor with the MCS.

**Is DTC 8-1 indicated?**

**YES** – Replace the ECM with a known good one and recheck.

**NO** – Faulty original sensor unit (TP sensor)

**DTC 8-2 (TP SENSOR HIGH VOLTAGE)**

**1. TP Sensor System Inspection**

Turn the ignition switch ON.

Check the TP sensor with the MCS with the throttle fully closed.

**Is about 5 V indicated?**

**YES** – GO TO STEP 3.

**NO** – GO TO STEP 2.

**2. TP Sensor Inspection**

Check that the TP sensor voltage increases continuously when moving the throttle from fully closed to fully opened using the data list menu of the MCS.

**Does the voltage increase continuously?**

**YES** – Intermittent failure

**NO** – Replace the TP sensor (sensor unit) with a known good one and recheck.

**3. TP Sensor Resistance Inspection**

Turn the ignition switch OFF.

Disconnect the sensor unit 5P (Black) connector [1] of the sensor side (page 7-15).

Check the resistance with the throttle position while operating the throttle grip.

**Connection: Yellow/blue – Green/orange**

**Standard: 0 – 5 kΩ**

**Is the resistance within 0 – 5 kΩ (Is the resistance changed by operating the throttle grip)?**

**YES** – GO TO STEP 4.

**NO** – Faulty sensor unit (TP sensor)

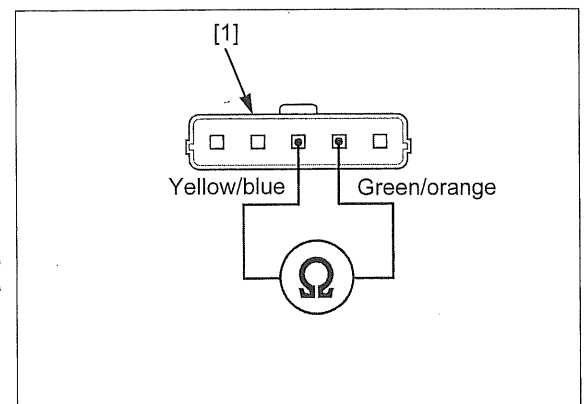

4. TP Sensor Power Input Voltage Inspection

Disconnect the sensor unit 5P (Black) connector (page 7-15).

Turn the ignition switch ON.

Measure the voltage at the sensor unit 5P (Black) connector [1] of the wire harness side.

**Connection: Yellow/white (+) – Green/orange (-)**

**Standard: 4.75 – 5.25 V**

**Is the voltage within 4.75 – 5.25 V?**

**YES** – Replace the ECM with a known good one and recheck.

**NO** – • Open circuit in the Green/orange wire  
• Open circuit in the Yellow/white wire

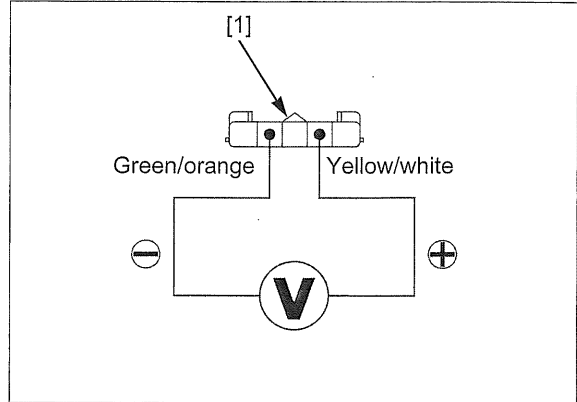

DTC 9-1 (IAT SENSOR LOW VOLTAGE)

1. IAT Sensor System Inspection

Turn the ignition switch ON.

Check the IAT sensor with the MCS.

**Is about 0 V indicated?**

**YES** – GO TO STEP 2.

**NO** – Intermittent failure

2. IAT Sensor Inspection

Turn the ignition switch OFF.

Disconnect the sensor unit 5P (Black) connector (page 7-15).

Turn the ignition switch ON.

Check the IAT sensor with the MCS.

**Is about 0 V indicated?**

**YES** – GO TO STEP 3.

**NO** – Faulty sensor unit (IAT sensor)

3. IAT Sensor Voltage Input Line Short Circuit Inspection

Check for continuity between the sensor unit 5P (Black) connector [1] of the wire side and ground.

**Connection: White/blue – Ground**

**Is there continuity?**

**YES** – Short circuit in the White/blue wire

**NO** – Replace the ECM with a known good one and recheck.

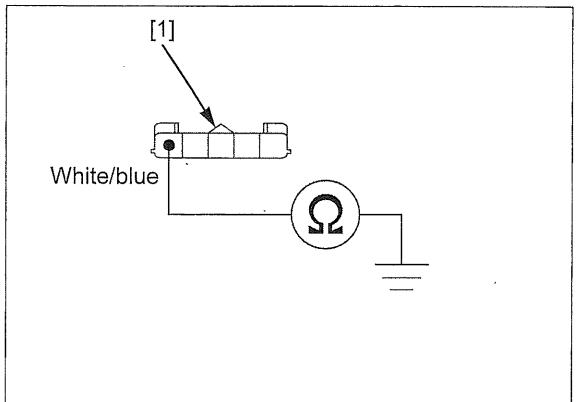



## DTC 9-2 (IAT SENSOR HIGH VOLTAGE)

**NOTE:**

Before starting the inspection, check for loose or poor contact on the sensor unit 5P (Black) connector and recheck the DTC.

### 1. IAT Sensor System Inspection

Turn the ignition switch ON.

Check the IAT sensor with the MCS.

**Is about 5 V indicated?**

**YES** – GO TO STEP 2.

**NO** – • Intermittent failure  
• Loose or poor contact on the sensor unit 5P (Black) connector

### 2. Sensor Unit Power Line Inspection

Check the sensor unit power line inspection (page 4-33).

**Is the sensor unit power line normal?**

**YES** – GO TO STEP 3.

**NO** – Replace or repair the abnormal circuit.

### 3. IAT Sensor Inspection

Turn the ignition switch OFF.

Disconnect the sensor unit 5P (Black) connector [1] (page 7-15).

Connect the IAT sensor terminals at the wire harness side with a jumper wire [2].

**Connection: White/blue – Green/orange**

Turn the ignition switch ON.

Check the IAT sensor with the MCS.

**Is about 0 V indicated?**

**YES** – Faulty sensor unit (IAT sensor)

**NO** – GO TO STEP 4.

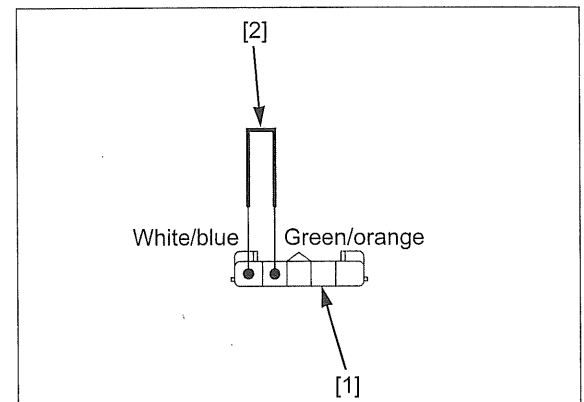

### 4. IAT Sensor Voltage Input Line Open Circuit Inspection

Turn the ignition switch OFF.

Disconnect the ECM 33P (Black) connector (page 4-49).

Check for continuity between the ECM 33P (Black) connector [1] and sensor unit 5P (Black) connector [2] of the wire harness side.

**Connection: A7 – White/blue**

**TOOL:**

Test probe, 2 pack **07ZAJ-RDJA110**

**Is there continuity?**

**YES** – Replace the ECM with a known good one and recheck.

**NO** – Open circuit in the White/blue wire

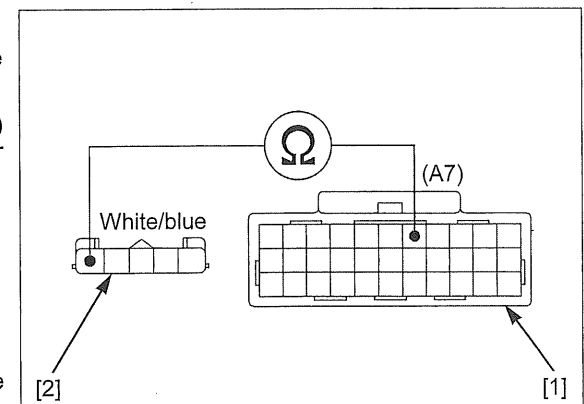

**DTC 12-1 (FUEL INJECTOR)**

**NOTE:**

- Before starting the inspection, check for loose or poor contact on the fuel injector 2P (Black) connector and ECM 33P (Black) connector, and recheck the DTC.

**1. Fuel Injector System Inspection**

Erase the DTC's (page 4-12).

Turn the ignition switch ON, start the engine and check the fuel injector with the MCS.

**Is the DTC 12-1 indicated?**

**YES** – GO TO STEP 2.

**NO** – Intermittent failure

**2. Fuel Injector Input Voltage Inspection**

Turn the ignition switch OFF.

Disconnect the fuel injector 2P (Black) connector (page 7-24).

Turn the ignition switch ON.

Measure the voltage between the fuel injector 2P (Black) connector [1] of the wire harness side and ground.

**Connection: Black/white (+) – Ground (-)**

**Standard: Battery voltage**

**Does the standard voltage exist?**

**YES** – GO TO STEP 3.

**NO** – Open circuit in the Black/white wire

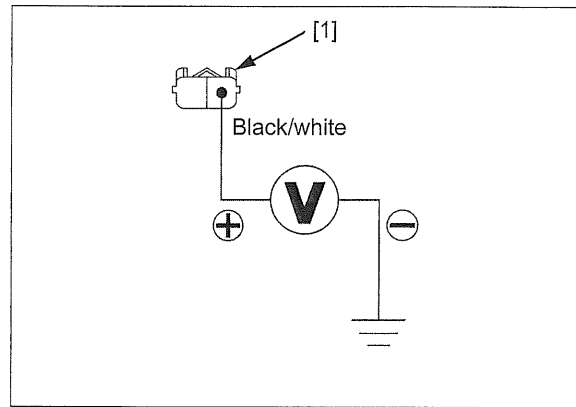

**3. Fuel Injector Signal Line Open Circuit Inspection**

Turn the ignition switch OFF.

Disconnect the ECM 33P (Black) connector (page 4-49).

Check for continuity between the ECM 33P (Black) connector [1] and fuel injector 2P (Black) connector [2] of the wire harness side.

**TOOL:**

**Test probe, 2 pack 07ZAJ-RDJA110**

**Connection: A2 – Pink/blue**

**Is there continuity?**

**YES** – GO TO STEP 4.

**NO** – Open circuit in the Pink/blue wire

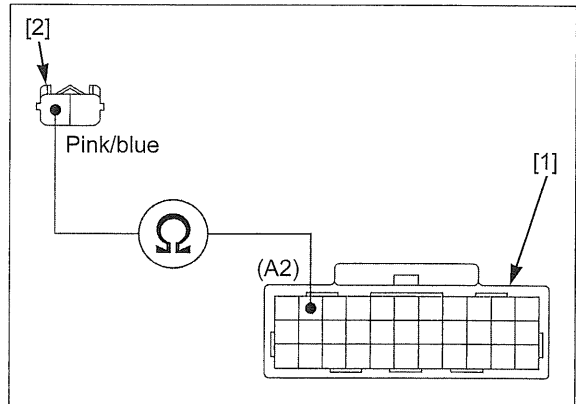

**4. Fuel Injector Signal Line Short Circuit Inspection**

Check for continuity between the fuel injector 2P (Black) connector [1] terminal of the wire harness side and ground.

**Connection: Pink/blue – Ground**

**Is there continuity?**

**YES** – Short circuit in the Pink/blue wire

**NO** – GO TO STEP 5.

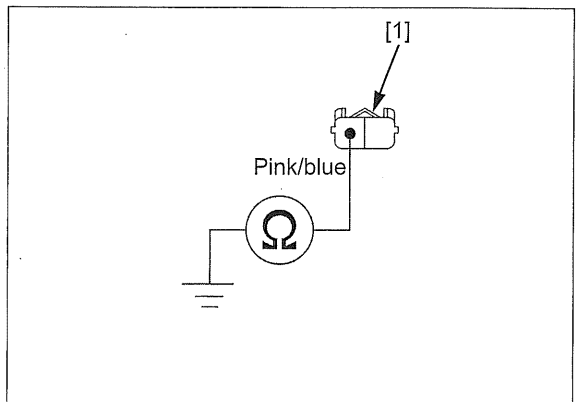

**5. Fuel Injector Resistance Inspection**

Measure the resistance of the fuel injector side 2P connector [1] terminals.

**Standard: 11 – 13 Ω (20°C)**  
(Fuel injector side terminals)

*Is the resistance within specification?*

**YES** – Replace the ECM with a known good one and recheck.

**NO** – Faulty fuel injector

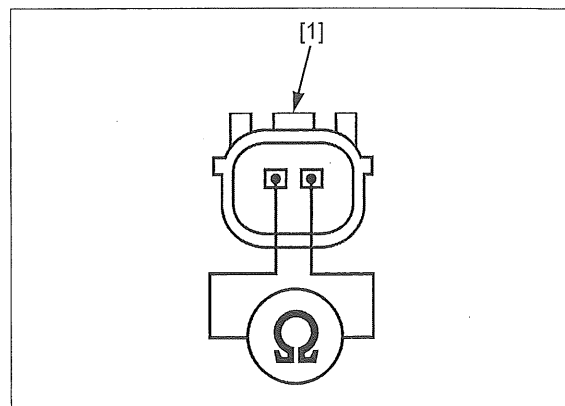

**DTC 21-1 (O<sub>2</sub> SENSOR)**

NOTE:

- Before starting the inspection, check for loose or poor contact on the O<sub>2</sub> sensor 1P (Black) connector and ECM 33P (Black) connector, and recheck the DTC.

**1. O<sub>2</sub> Sensor Open Circuit Inspection**

Turn the ignition switch OFF.

Disconnect the O<sub>2</sub> sensor 1P (Black) connector (page 4-53).

Disconnect the ECM 33P (Black) connector (page 4-49).

Check for continuity between the ECM 33P (Black) connector [1] of the wire harness side and O<sub>2</sub> sensor 1P (Black) connector [2] of the wire harness side.

**TOOL:**

**Test probe, 2 pack**                      **07ZAJ-RDJA110**

**Connection: A9 – Black/orange**

*Is there continuity?*

**YES** – GO TO STEP 2.

**NO** – Open circuit in the Black/orange wire

**2. O<sub>2</sub> Sensor Short Circuit Inspection**

Check for continuity between the O<sub>2</sub> sensor 1P (Black) connector terminal [1] of the wire harness side and ground.

**TOOL:**

**Test probe, 2 pack**                      **07ZAJ-RDJA110**

**Connection: Black/orange – Ground**

*Is there continuity?*

**YES** – Short circuit in the Black/orange wire

**NO** – GO TO STEP 3.

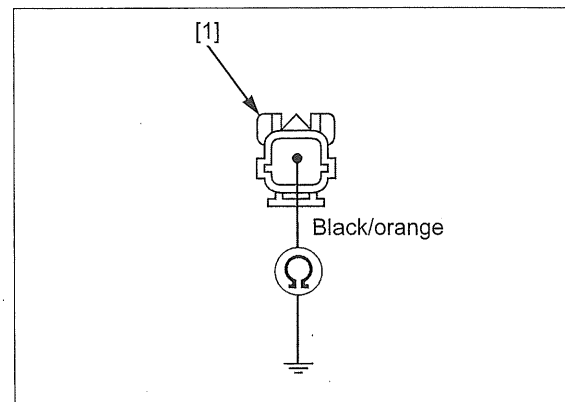
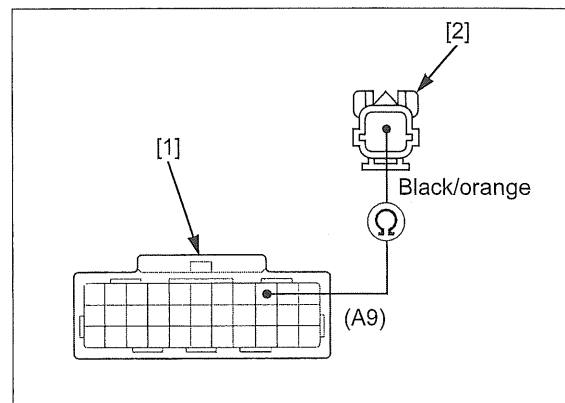

## 3. O<sub>2</sub> Sensor Inspection

Replace the O<sub>2</sub> sensor with a known good one (page 4-53).  
Erase the DTC's (page 4-12).

Start the engine and warm it up to normal operating temperature.

Test-ride the scooter and recheck O<sub>2</sub> sensor with the MCS.

### Is the DTC 21-1 indicated?

**YES** – Replace the ECM with a known good one and recheck.

**NO** – Faulty original O<sub>2</sub> sensor

## DTC 29-1 (IACV)

### NOTE:

Before starting the inspection, check for loose or poor contact on the IACV 4P (Black) connector and recheck the DTC.

### 1. Recheck DTC

Erase the DTC's (page 4-12).

Turn the ignition switch ON.

Check the IACV with the MCS.

### Is the DTC 29-1 indicated?

**YES** – GO TO STEP 2.

**NO** – • Intermittent failure  
• Loose or poor contact on the IACV 4P (Black) connector

### 2. IACV Short Circuit Inspection

Turn the ignition switch OFF.

Disconnect the IACV 4P (Black) connector [1].

Check for continuities between the IACV 4P (Black) connector of the wire harness side and ground.

**Connection:** Light green/black – Ground  
Brown/red – Ground  
Black/red – Ground  
Gray/red – Ground

### Is there continuity?

**YES** – • Short circuit in the Light green/black or Brown/red wire  
• Short circuit in the Black/red or Gray/red wire

**NO** – GO TO STEP 3.

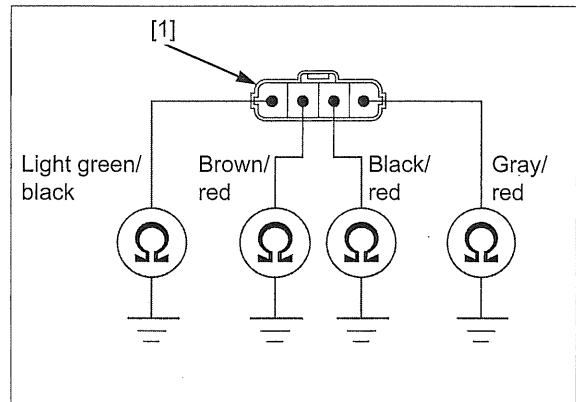

**3. IACV Open Circuit Inspection**

Disconnect the ECM 33P (Black) connector (page 4-49).

Check the continuities between the ECM 33P (Black) connector [1] and IACV 4P (Black) connector [2] of the wire harness side.

- Connection:** A14 – Light green/black  
 A16 – Black/red  
 A26 – Gray/red  
 A27 – Brown/red

**TOOL:**

Test probe, 2 pack **07ZAJ-RDJA110**

*Is there continuity?*

**YES** – GO TO STEP 4.

- NO** – • Open circuit in the Light green/black or Brown/red wire  
 • Open circuit in the Black/red or Gray/red wire

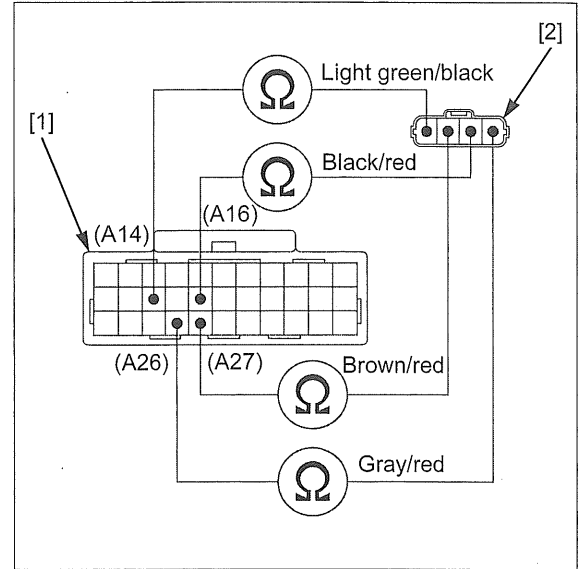

**4. IACV Resistance Inspection**

Measure the resistance of the IACV side 4P (Black) connector [1] terminals.

- Connection:** Light green/black – Gray/red  
 Brown/red – Black/red

**Standard:** 110 – 150 Ω (25°C/77°F)

*Is the resistance within 110 – 150 Ω (25°C/77°F)?*

**YES** – GO TO STEP 5.

**NO** – Faulty IACV

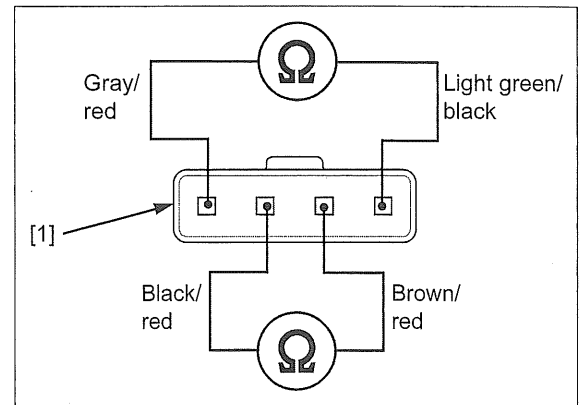

**5. IACV Short Circuit Inspection**

Check for continuity of the IACV side 4P (Black) connector [1] terminals.

- Connection:** Gray/red – Black/red  
 Brown/red – Light green/black

**Standard:** No continuity

*Is there continuity?*

**YES** – Faulty IACV. Replace the IACV with a new one and recheck.

**NO** – Replace the ECM with known good one and recheck.

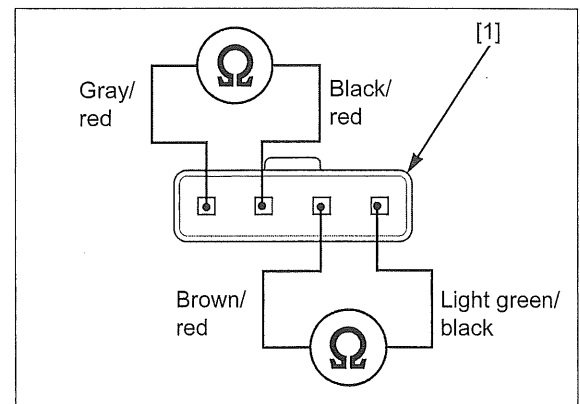

**DTC 33-2 (EEPROM)**

**1. Recheck DTC**

Erase the DTC's (page 4-12).

Turn the ignition switch ON.

Recheck the ECM EEPROM.

**Is the DTC 33-2 indicated?**

**YES** – Replace the ECM with a known good one and recheck.

**NO** – Intermittent failure

**DTC 52-1 (CKP SENSOR)**

- Before starting the inspection, check for loose or poor contact on the CKP sensor 6P (Black) connector and ECM 33P connectors and recheck the DTC.

**1. CKP Sensor Circuit Inspection**

Turn the ignition switch OFF.

Disconnect the CKP sensor 6P (Black) connector (page 14-4).

Check the connector for loose contacts or corroded terminals.

Measure the voltage between the CKP sensor 6P (Black) connector [1] of the wire harness side and ground.

- Connection:** White/red (+) – Ground (-)  
 White/blue (+) – Ground (-)  
 White/black (+) – Ground (-)  
 Blue/yellow (+) – Ground (-)

**Standard:** 5 – 10 V

**Connection:** Brown/black (+) – Blue/green (-)

**Standard:** Battery voltage

**Does the standard voltage exist?**

**YES** – GO TO STEP 2.

**NO** – Open circuit in the wire harness between the ECM and CKP sensor connector

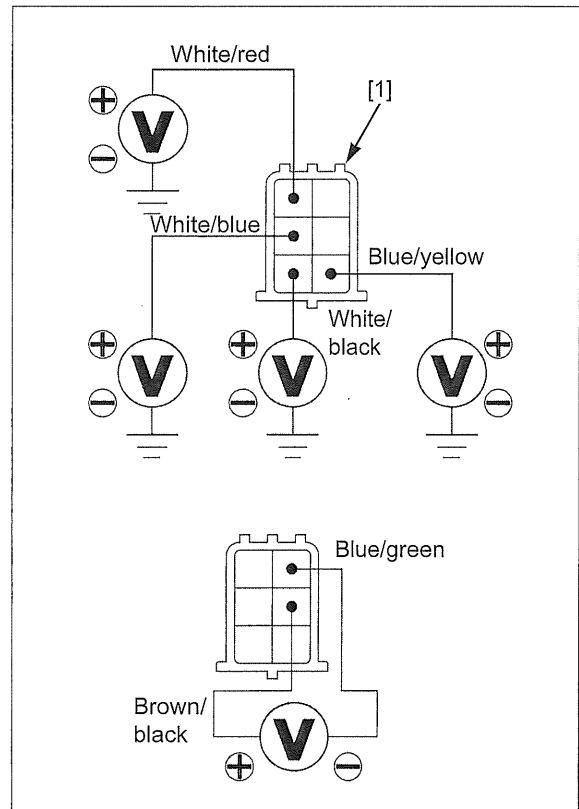

**2. CKP Sensor Inspection**

Replace the CKP sensor with a known good one (page 14-4).

Erase the DTC's (page 4-12).

Start the engine and warm it up.

Test-ride the scooter and recheck the DTC.

**Is the DTC 52-1 indicated?**

**YES** – Replace the ECM with a known good one and recheck.

**NO** – Faulty original CKP sensor

## MIL CIRCUIT INSPECTION ('13 MODEL)

### WHEN THE IGNITION SWITCH IS TURNED ON, THE MIL DOES NOT COME ON

Turn the ignition switch OFF.

Disconnect the ECM 21P (Black) connector.

Ground the ECM 21P (Black) connector [1] terminal of the wire harness side connector with a jumper wire.

**CONNECTION: A20 (White/blue) – Ground**

**TOOL:**

**Test probe, 2 pack**                      **07ZAJ-RDJA110**

Turn the ignition switch ON and engine stop switch "O", the MIL should come on.

- If the MIL comes on, replace the ECM with a known good one and recheck.
- If the MIL does not come on, check for open circuit in the White/blue wire between the speedometer and ECM.

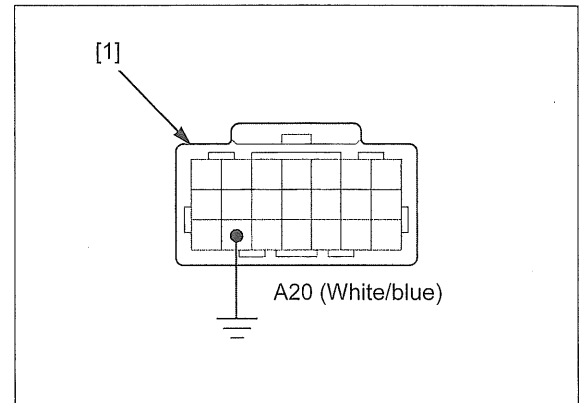

### WHEN THE IGNITION SWITCH IS TURNED ON, THE MIL DOES NOT GO OFF WITHIN A FEW SECONDS (ENGINE STARTS)

Turn the ignition switch OFF.

Disconnect the ECM 21P (Black) connector.

Turn the ignition switch ON and engine stop switch "O", the MIL should stay off.

- If the MIL comes on, check for short circuit in the White/blue wire between the speedometer and ECM.
- If the MIL turns off, check the following.

Disconnect the ECM 21P (Gray) connector.

Check for continuity between the ECM 21P (Gray) connector [1] and ground.

**CONNECTION: B20 (Brown) – B14 (Blue/green)**  
**STANDARD: No continuity**

**TOOL:**

**Test probe, 2 pack**                      **07ZAJ-RDJA110**

- If there is continuity, check for short a circuit between the Brown wire and Blue/green wire.
- If there is no continuity, replace the ECM with a known good one and recheck.

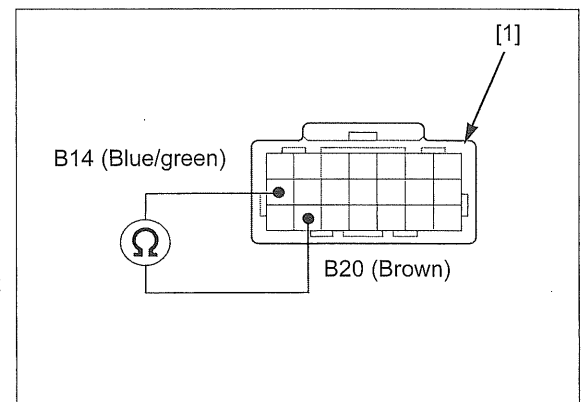

## MIL CIRCUIT INSPECTION (AFTER '13 MODEL)

### WHEN THE IGNITION SWITCH IS TURNED ON, THE MIL DOES NOT COME ON

Turn the ignition switch OFF.

Disconnect the ECM 33P (Black) connector (page 4-49).

Ground the ECM 33P (Black) connector [1] terminal of the wire harness side connector with a jumper wire.

**Connection: A15 – Ground**

**TOOL:**

**Test probe, 2 pack**                      **07ZAJ-RDJA110**

Turn the ignition switch ON, the MIL should come on.

- If the MIL comes on, replace the ECM with a known good one and recheck.
- If the MIL does not come on, check for open circuit in the Light green wire between the combination meter and ECM.

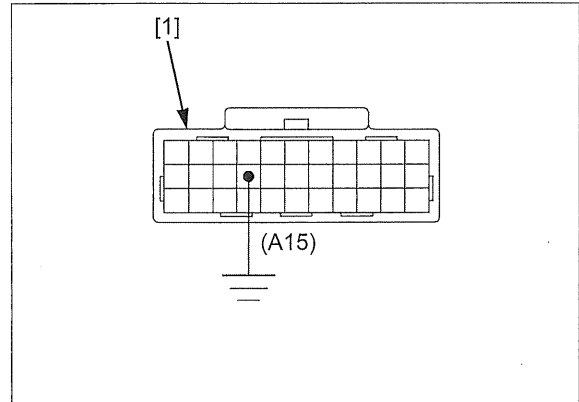

### WHEN THE IGNITION SWITCH IS TURNED ON, THE MIL DOES NOT GO OFF WITHIN A FEW SECONDS (ENGINE STARTS)

Turn the ignition switch OFF.

Disconnect the ECM 33P (Black) connector (page 4-49).

Turn the ignition switch ON, the MIL should stay off.

- If the MIL comes on, check for a short circuit in the Light green wire between the combination meter and ECM.
- If the MIL turns off, check the following.

Check for continuity between the ECM 33P (Black) connector [1].

**Connection: A32 – A17**

**Standard: No continuity**

**TOOL:**

**Test probe, 2 pack**                      **07ZAJ-RDJA110**

- If there is continuity, check for a short circuit between the ECM and DLC.
- If there is no continuity, replace the ECM with a known good one and recheck.

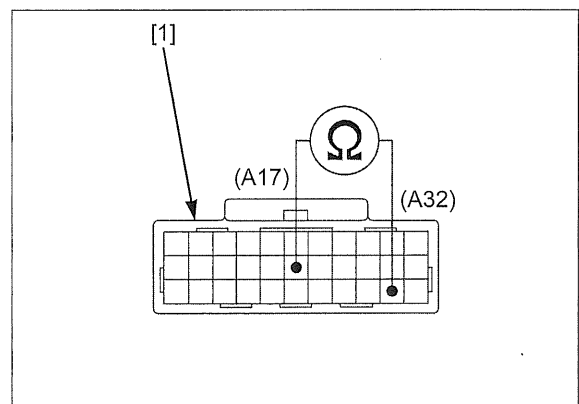



## ECM

**REMOVAL/ INSTALLATION ('13 MODEL)**

Remove the right front cover (page 2-15).

Pull off the dust cover [1].

Disconnect the following:

- ECM 21P (Black) connector [2]
- ECM 21P (Gray) connector [3]
- ECM 5P connector [4]
- ECM 3P (Black) connector [5]

Remove the three bolts [1] and ECM [2].

Installation is in the reverse order of removal.

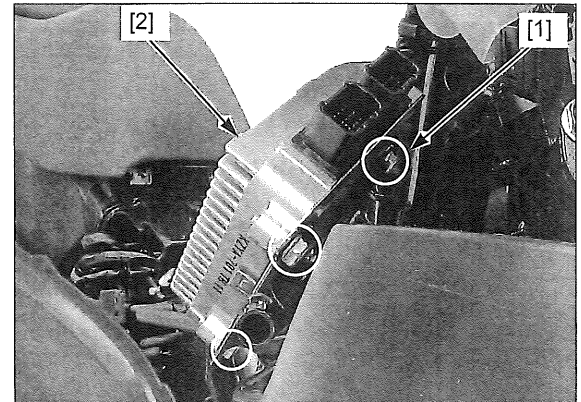
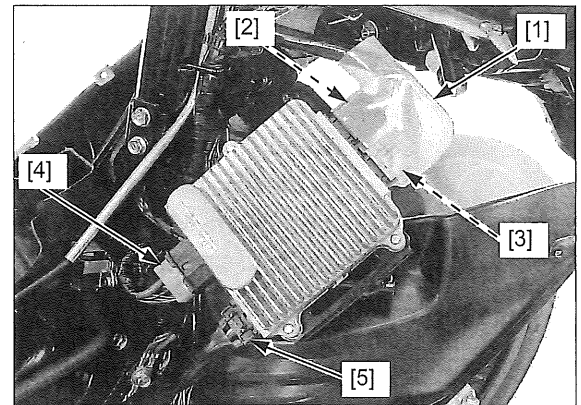
**REMOVAL/INSTALLATION (AFTER '13 MODEL)**

Remove the inner cover (page 2-13).

Pull off the dust cover [1].

Disconnect the following:

- ECM 33P (Black) connector [2]
- ECM 3P (Black) connector [3]
- ECM 5P connector [4]

Remove the three bolts [5] and ECM [6].

Installation is in the reverse order of removal.

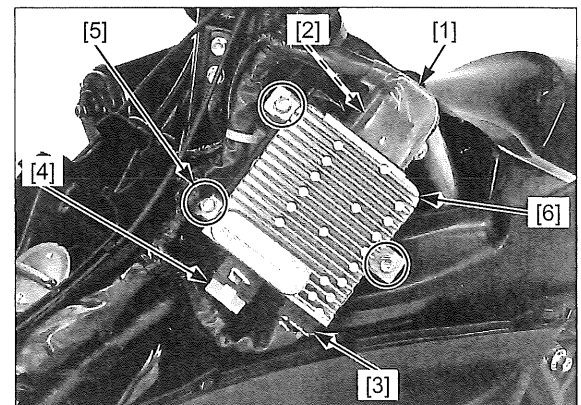

**INSPECTION ('13 MODEL)**

**MIL DOES NOT COME ON AND FUEL PUMP DOES NOT OPERATE (ECM DOES NOT OPERATE)**

- Before starting the inspection, check for loose or poor contact on the ECM connectors, and recheck the MIL blinking.
- Make sure that the battery is fully charged.

**1. Fuse Inspection**

Check for a blown fuse.

**Is the fuse blown?**

**YES** – Replace the fuse.

**NO** – GO TO STEP 2.

**2. ECM Ground Line Inspection**

Turn the ignition switch OFF.

Disconnect the ECM 21P (Gray) connector and 5P connector.

Check for continuity between the ECM 5P connector [1] of the wire harness side and ground.

**TOOL:**

**Test probe, 2 pack**                      **07ZAJ-RDJA110**

**CONNECTION: Green – Ground**

**Green/black – Ground**

**Is there continuity?**

**YES** – GO TO STEP 3.

- NO** –
- Open circuit in the Green wire
  - Open circuit in the Green/black wire

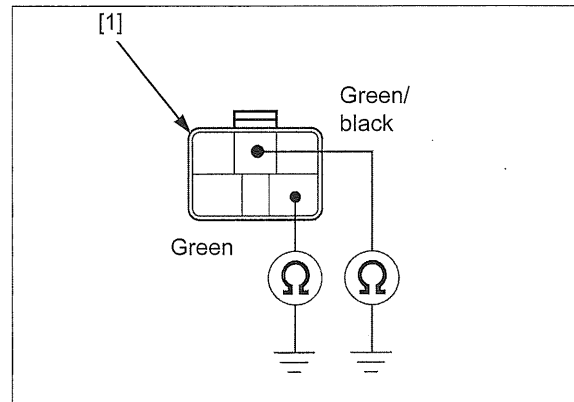

**3. Sensor Unit Power Input Line Short Circuit Inspection**

Turn the ignition switch OFF.

Disconnect the sensor unit 5P (Black) connector.

Check for continuity between the sensor unit 5P (Black) connector [1] of the wire harness side and ground.

**CONNECTION: Yellow/orange – Ground**

**STANDARD: No continuity**

**Is there continuity?**

**YES** – Short circuit in the Yellow/orange wire

**NO** – GO TO STEP 4.

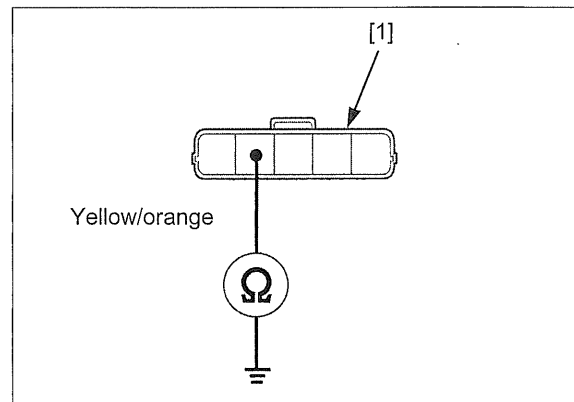

**4. ECM Power Line Inspection**

Turn the ignition switch ON and engine stop switch "O".

Measure the voltage between the ECM 21P (Black) connector [1] of the wire harness side and ground.

**TOOL:**

Test probe, 2 pack                      07ZAJ-RDJA110

**CONNECTION:**

A16 (Black/green) (+) – Ground (-)

*Does battery voltage exist?*

**YES** – Replace the ECM with a known good one and recheck.

- NO** –
- Open circuit in the Black/white wire between the ignition switch and engine stop switch
  - Open circuit in the Black/green wire between the engine stop switch and ECM

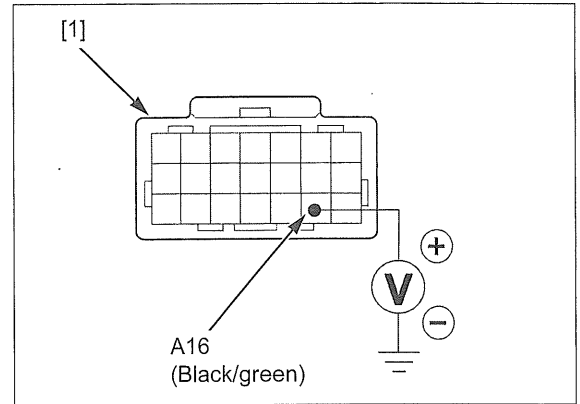

**INSPECTION (AFTER '13 MODEL)**

**MIL DOES NOT COME ON AND FUEL PUMP DOES NOT OPERATE (ECM DOES NOT OPERATE)**

- Before starting the inspection, check for loose or poor contact on the ECM connectors, and recheck the MIL blinking.
- Make sure that the battery is fully charged.

**1. Fuse Inspection**

Check for a blown IGN. INJ. F\_PUMP fuse (10 A).

*Is the fuse blown?*

**YES** – Replace the fuse.

**NO** – GO TO STEP 2.

**2. ECM Ground Line Inspection**

Turn the ignition switch OFF.

Disconnect the ECM 5P connector (page 4-49).

Check for continuity between the ECM 5P connector [1] of the wire harness side and ground.

**Connection: Green – Ground**

**TOOL:**

Test probe, 2 pack                      07ZAJ-RDJA110

*Is there continuity?*

**YES** – GO TO STEP 3.

**NO** – Open circuit in Green wire

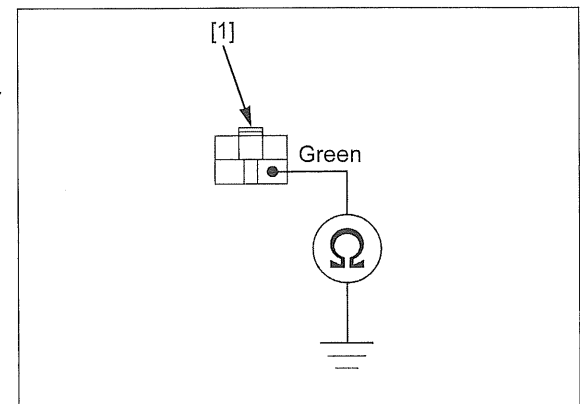

## PGM-FI SYSTEM

### 3. ECM Power Line Inspection

Disconnect the ECM 33P (Black) connector (page 4-49).

Turn the ignition switch ON.

Measure the voltage between the ECM 33P (Black) connector [1] of the wire harness side and ground.

**Connection:** A24 (+) – Ground (-)

**TOOL:**

Test probe, 2 pack                      07ZAJ-RDJA110

**Does the battery voltage exist?**

**YES** – Replace the ECM with a known good one and recheck.

**NO** – Open circuit in the Black/white wire between the ignition switch and ECM.

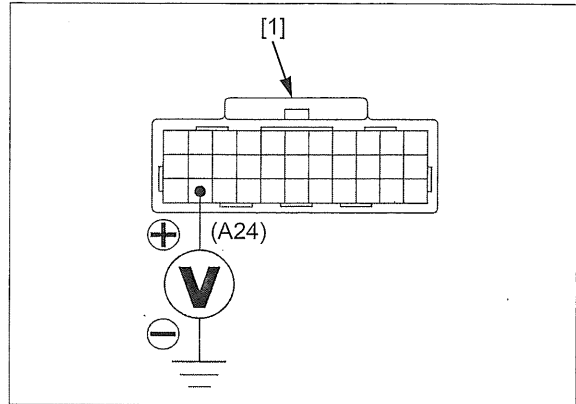

## ECT SENSOR

### REMOVAL/INSTALLATION

Remove the right side cover (page 2-8).

Drain the coolant (page 9-5).

*Remove the ECT sensor while the engine is cold.* Disconnect the ECT sensor 2P (Black) connector [1] from the sensor.

*Do not apply engine oil to this O-ring.* Remove the ECT sensor [2] and replace the O-ring [3] with a new one.

Tighten the ECT sensor to the specified torque.

**TORQUE: 12 N·m (1.2 kgf·m, 9 lbf·ft)**

Fill the cooling system with recommended coolant (page 9-5).

Install the right side cover (page 2-8).

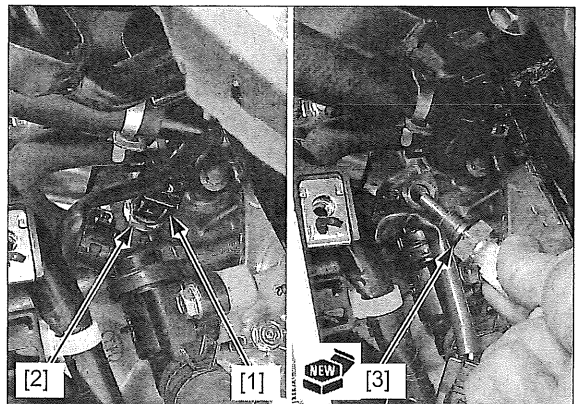

### INSPECTION

Remove the ECT sensor (page 4-52).

Heat the coolant with an electric heating element. Suspend the ECT sensor [1] in heated coolant and check the continuity through the sensor as the coolant heats up.

*Wear insulated gloves and adequate eye protection. Keep flammable materials away from the burner.*

- Soak the ECT sensor in coolant up to its threads with at least 40 mm (1.57 in) from the bottom of the pan to the bottom of the sensor.
- Keep temperature constant for 3 minutes before testing. A sudden change of temperature will result in incorrect readings. Do not let the thermometer [2] or ECT sensor touch the pan.

**CONNECTION: A – B**

Temperature °C (°F)	40 (104)	100 (212)
Resistance (kΩ)	1.0 – 1.3	0.1 – 0.2

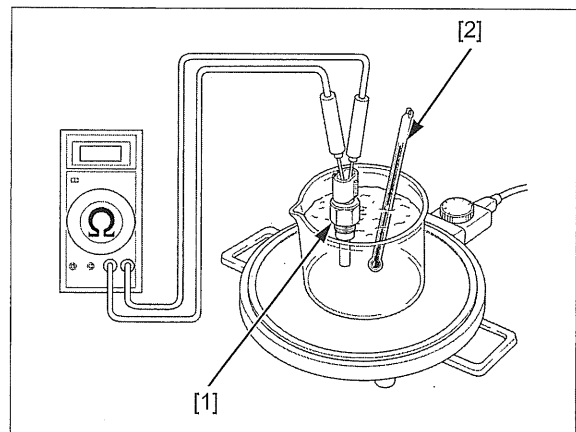

Replace the ECT sensor if it is out of specification.

Install the ECT sensor (page 4-52).

## O<sub>2</sub> SENSOR

### NOTICE

- Do not get grease, oil or other materials in the O<sub>2</sub> sensor air hole.
- The O<sub>2</sub> sensor may be damaged if dropped. Replace it with a new one, if dropped.

### REMOVAL ('13 MODEL)

*Replace the O<sub>2</sub> sensor while the engine is cold.*

Remove the left side cover (page 2-8).

Release the wire band boss [1] from the stay.  
Release the O<sub>2</sub> sensor 1P (Black) connector [2] from the stay and disconnect it.

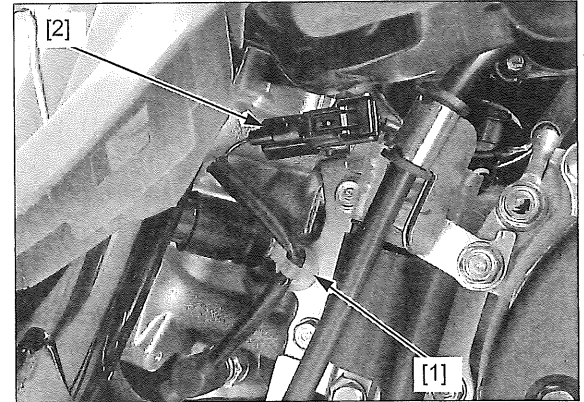

Hold the center of the O<sub>2</sub> sensor cap [1] as shown. Disconnect the cap from the sensor while slightly turning it, less than 1/2 of a turn.

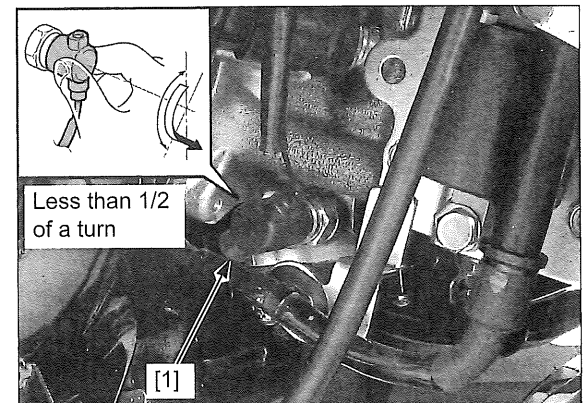

*Remove the O<sub>2</sub> sensor while the engine is cold.*

Remove the O<sub>2</sub> sensor [1] from the cylinder head.

- Do not use an impact wrench when removing or installing the O<sub>2</sub> sensor, or it may be damaged.

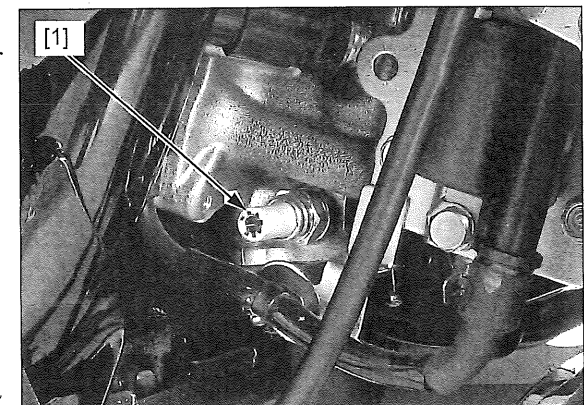

## PGM-FI SYSTEM

### INSTALLATION ('13 MODEL)

Install and tighten the O<sub>2</sub> sensor [1] to the cylinder head to the specified torque.

**TORQUE: 24.5 N·m (2.5 kgf·m, 18 lbf·ft)**

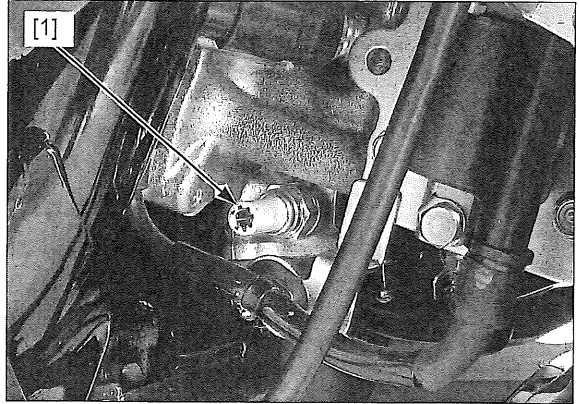

Connect the O<sub>2</sub> sensor cap [1] to the O<sub>2</sub> sensor [2] by pushing it straight.

#### NOTICE

- Be careful not to tilt the O<sub>2</sub> sensor cap when connecting the cap to the O<sub>2</sub> sensor.

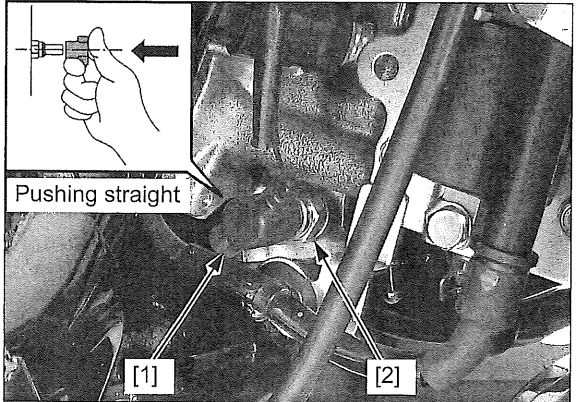

Connect the O<sub>2</sub> sensor 1P (Black) connector [1] and set it to the stay.

Set the wire band boss [2] to the stay.

After installation, make sure the exhaust gas does not leak.

Install the left side cover (page 2-8).

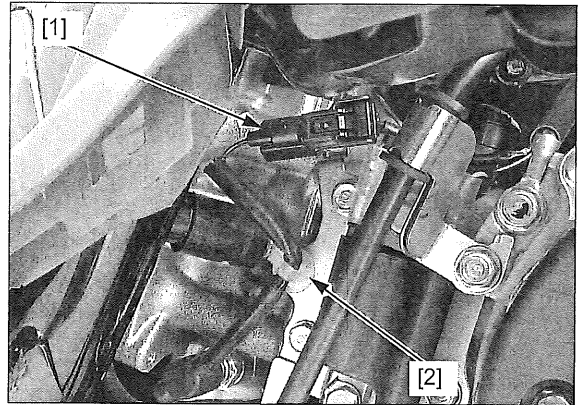

**REMOVAL/INSTALLATION (AFTER '13 MODEL)****NOTICE**

- Do not get grease, oil or other materials in the O<sub>2</sub> sensor air hole.
- The O<sub>2</sub> sensor may be damaged if dropped. Replace it with a new one, if dropped.
- Handle the O<sub>2</sub> sensor with care.
- Be careful not to damage the sensor wire.
- Do not use an impact wrench while removing or installing the O<sub>2</sub> sensor.

Remove the side cover (page 2-8).

Disconnect the O<sub>2</sub> sensor 1P (Black) connector [1] and release the wire [2] from the clamp [3].

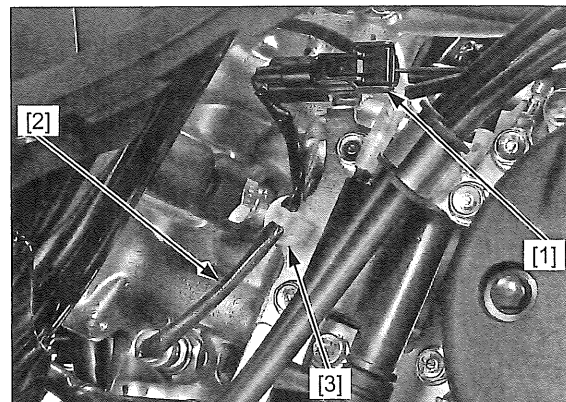

Remove the O<sub>2</sub> sensor [1] using the special tool.

**TOOL:**  
FRXM17 (Snap on) or equivalent [2]

Installation is in the reverse order of removal.

**TORQUE:**  
O<sub>2</sub> sensor: 24.5 N·m (2.5 kgf·m, 18 lbf·ft)

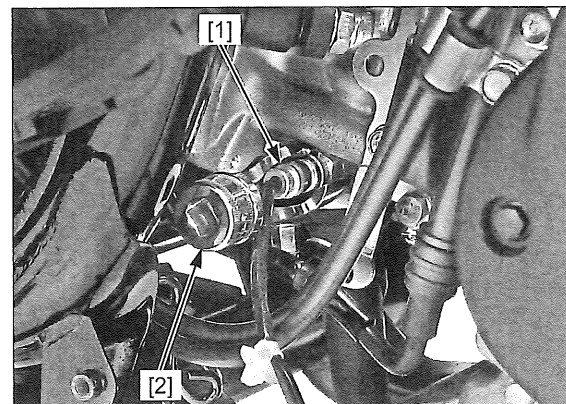

---

**MEMO**

---



# 5. IGNITION SYSTEM

---

SYSTEM LOCATION .....	5-2	IGNITION SYSTEM INSPECTION .....	5-6
SYSTEM DIAGRAM .....	5-3	IGNITION COIL .....	5-7
SERVICE INFORMATION.....	5-4	IGNITION TIMING .....	5-7
TROUBLESHOOTING .....	5-5		

# IGNITION SYSTEM

## SYSTEM LOCATION

'13 model:

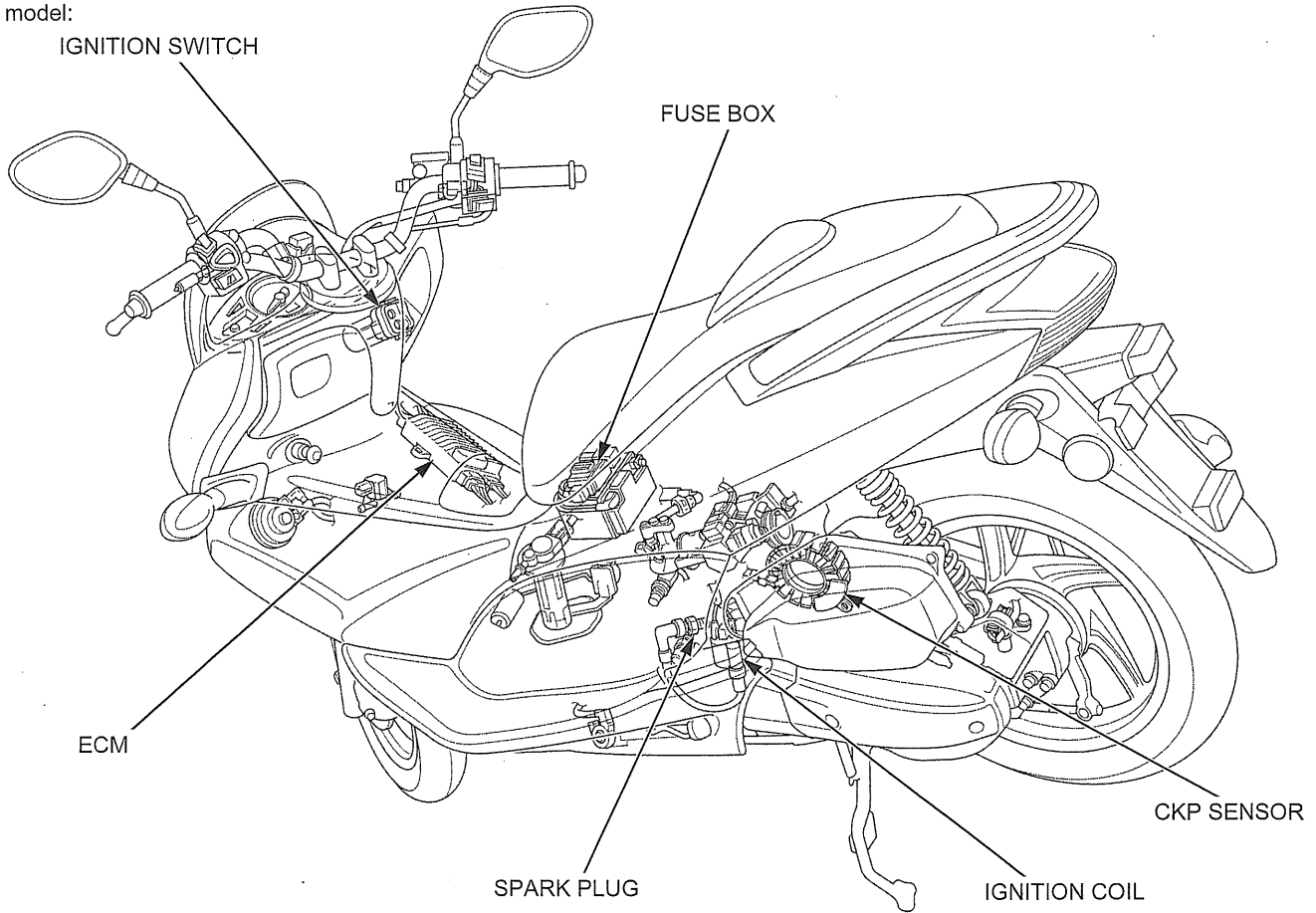

After '13 model:

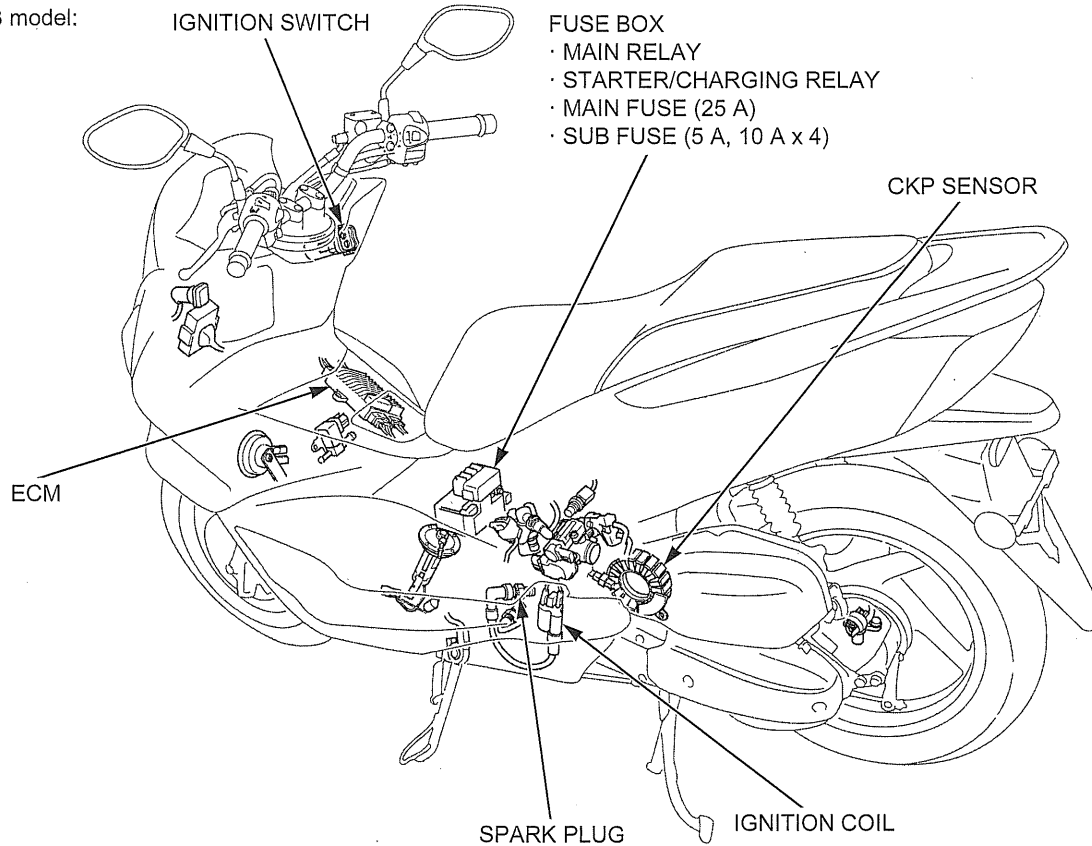

SYSTEM DIAGRAM

'13 model:

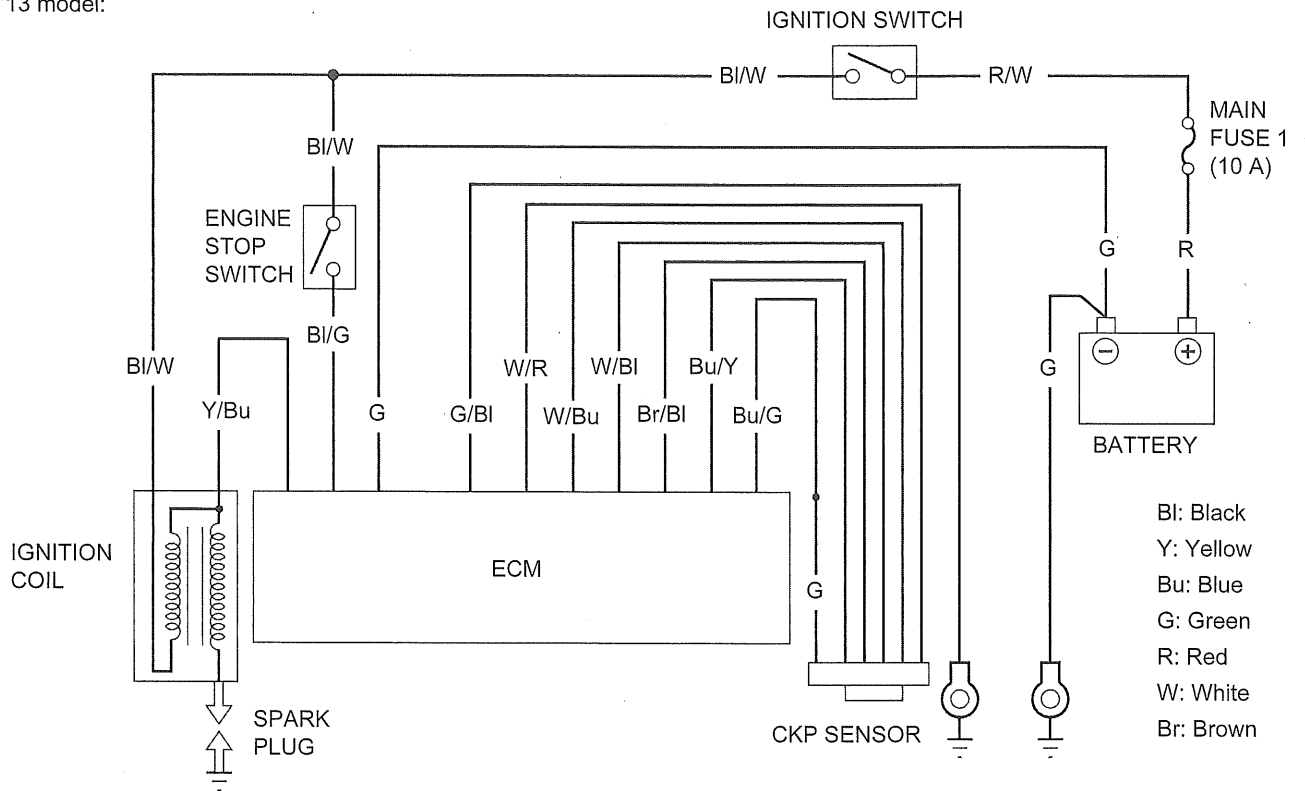

After '13 model:

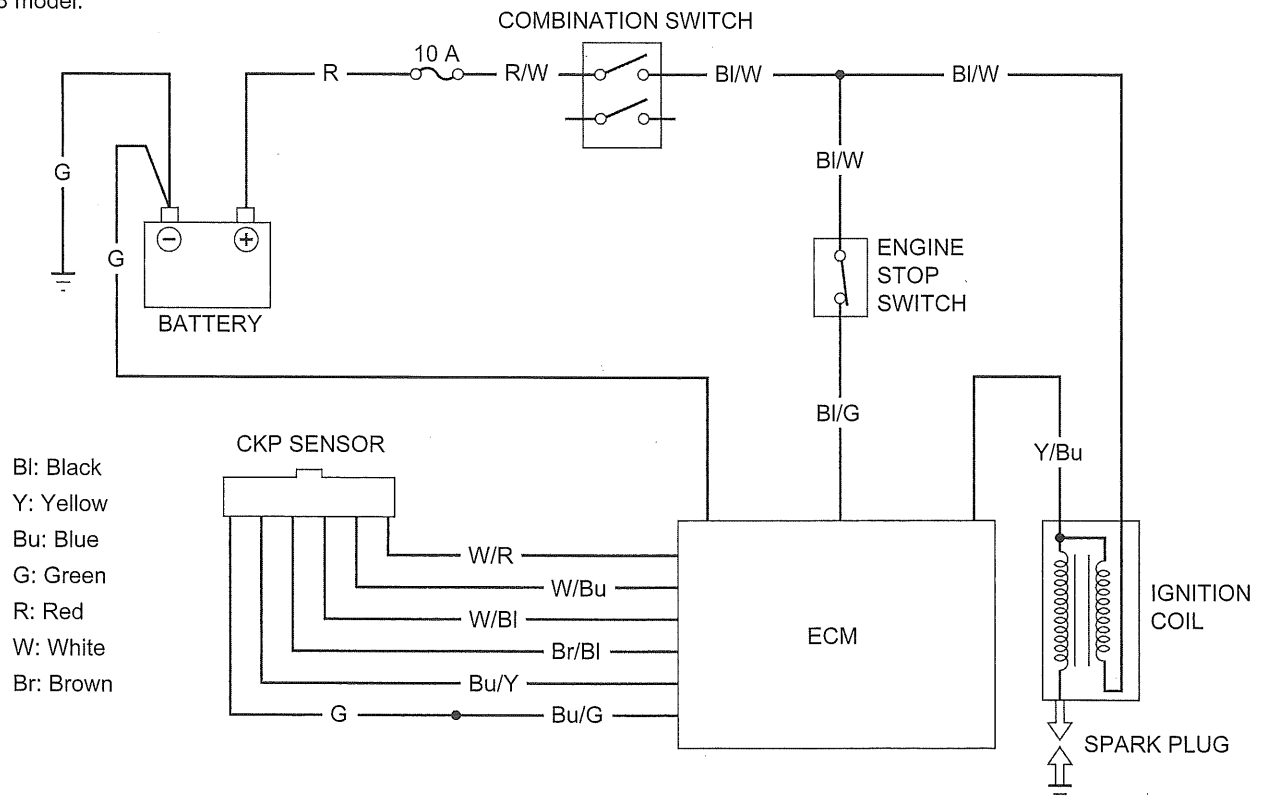

## IGNITION SYSTEM

# SERVICE INFORMATION

### GENERAL

- The ECM may be damaged if dropped. Also, if the connector is disconnected when current is flowing, the excessive voltage may damage the ECM. Always turn the ignition switch OFF before servicing.
- Use spark plug with the correct heat range. Using spark plug with an incorrect heat range can damage the engine.
- Some electrical components may be damaged if terminals or connectors are connected or disconnected while the ignition switch is turned ON and current is present.
- When servicing the ignition system, always follow the steps in the troubleshooting (page 5-5).
- The ignition timing cannot be adjusted since the ECM is factory preset.
- A faulty ignition system is often related to poor connections. Check those connections before proceeding.
- Make sure the battery is adequately charged. Using the starter with a weak battery results in a slower engine cranking speed as well as no spark at the spark plug.
- Inspect the following:
  - Spark plug (page 3-9)
  - Ignition switch (page 21-22)
  - CKP sensor (page 6-11)
- Refer to CKP sensor service (page 14-4).

### SPECIFICATIONS

ITEM	SPECIFICATIONS
Spark plug	CPR7EA-9 (NGK)
Spark plug gap	0.8 – 0.9 mm (0.03 – 0.04 in)
Ignition coil peak voltage	100 V minimum
Ignition timing	12° BTDC at idle speed

### TOOLS

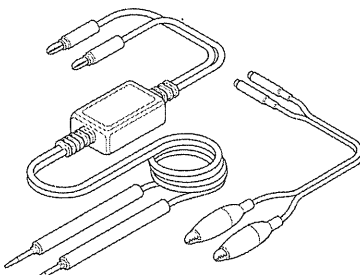
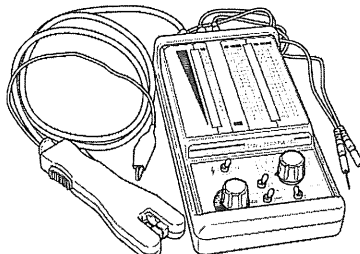
<p>Peak voltage adaptor 07HGJ-0020100 (Not available in U.S.A.)</p>  <p>with commercially available digital multimeter (impedance 10 MΩ/DCV minimum)</p>	<p>IgnitionMate peak voltage tester MTP07-0286 (U.S.A. only)</p> 	
---	--	--

## TROUBLESHOOTING

- Inspect the following before diagnosing the system.
  - Turn the ignition switch ON and engine stop switch "O", check the DTC (page 4-15). MIL 52 blinks (CKP sensor) is indicated only when the engine is cranked.
  - Faulty spark plug
  - Loose spark plug cap or spark plug wire connection
  - Water in the spark plug cap (Leaking the ignition coil secondary voltage)
- "Initial voltage" of the ignition primary coil is the battery voltage with the ignition switch turned ON. (The engine is not cranked by the starter.)

### No spark at spark plug

UNUSUAL CONDITION		PROBABLE CAUSE (Check in numerical order)
Ignition coil primary voltage	No initial voltage with the ignition switch turned ON and engine stop switch "O". (Other electrical components are normal)	<ol style="list-style-type: none"> <li>1. An open circuit or loose connection in the Black/white wire.</li> <li>2. Loose or poor connection of the ignition coil primary wire terminal or an open circuit in the primary coil.</li> <li>3. Faulty ECM (in cases when the initial voltage is normal when ECM 21P (Black) connector is disconnected).</li> </ol>
	Initial voltage is normal, but it drops by 2 – 4 V while cranking the engine.	<ol style="list-style-type: none"> <li>1. Incorrect peak voltage adaptor connections. (System is normal if measured voltage is over the specifications with reverse connections.)</li> <li>2. Battery is undercharged. (Voltage drops largely when the engine is started.)</li> <li>3. Loose or poor connection or an open circuit in the Yellow/blue wire between the ignition coil and ECM.</li> <li>4. A short circuit in the ignition primary coil.</li> <li>5. Faulty CKP sensor (Check the DTC: page 4-15)</li> <li>6. Faulty ECM (in cases where No. 1 through 5 are normal).</li> </ol>
	Initial voltage is normal but there is no peak voltage while cranking the engine.	<ol style="list-style-type: none"> <li>1. Incorrect peak voltage adaptor connections. (System is normal if measured voltage is over the specifications with reverse connections.)</li> <li>2. Faulty peak voltage adaptor.</li> <li>3. Faulty ECM (in cases where above No. 1 and 2 are normal).</li> </ol>
	Initial voltage is normal but peak voltage is lower than the standard value.	<ol style="list-style-type: none"> <li>1. The multimeter impedance is too low; below 10 MΩ/DCV.</li> <li>2. Cranking speed is too slow. (Battery is undercharged.)</li> <li>3. The sampling timing of the tester and measured pulse were not synchronized. (System is normal if measured voltage is over the standard voltage at least once.)</li> <li>4. Faulty ECM (in cases where above No. 1 through 3 are normal).</li> </ol>
	Initial and peak voltages are normal but no spark jumps.	<ol style="list-style-type: none"> <li>1. Faulty spark plug or leaking ignition coil secondary current.</li> <li>2. Faulty ignition coil.</li> </ol>

## IGNITION SYSTEM INSPECTION

- If there is no spark present at the plug, check all connections for loose or poor contact before measuring the peak voltage.
- Use a commercially available digital multimeter (impedance 10 MΩ/DCV minimum).
- The display value differs depending upon the internal impedance of the multimeter.
- If the peak voltage tester (U.S.A. only) is used, follow the manufacturer's instruction.

Connect the peak voltage adapter [1] to the digital multimeter [2], or use the imrie diagnostic tester.

**TOOL:**

**IgnitionMate peak voltage tester** MTP07-0286 (U.S.A. only) or  
**Peak voltage adaptor** 07HGJ-0020100 (Not available in U.S.A.)  
 with commercially available digital multimeter (impedance 10 MΩ/DCV minimum)

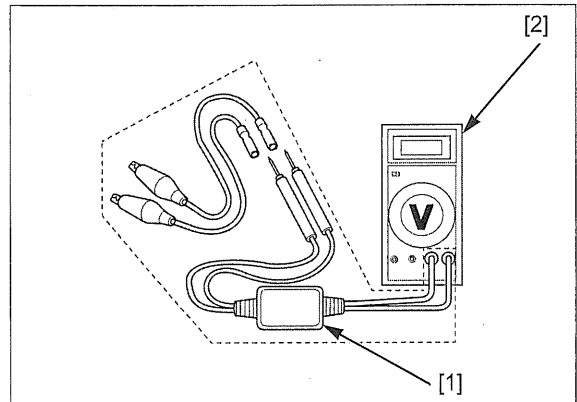

### IGNITION COIL PRIMARY PEAK VOLTAGE

- Check all system connections before inspection. If the system is disconnected, incorrect peak voltage might be measured.
- Check cylinder compression and check that the spark plug is installed correctly.

Support the scooter with its centerstand on a level surface.

Disconnect the plug cap from the spark plug (page 3-9). Connect a known good spark plug [1] to the spark plug cap and ground it to the cylinder head stay bolt as done in a spark test.

With the ignition coil primary wires connected, connect the imrie diagnostic tester or peak voltage adaptor probes to the ignition coil primary terminal [2] and ground.

**TOOL:**

**IgnitionMate peak voltage tester** MTP07-0286 (U.S.A. only) or  
**Peak voltage adaptor** 07HGJ-0020100 (Not available in U.S.A.)  
 with commercially available digital multimeter (impedance 10 MΩ/DCV minimum)

**CONNECTION: Yellow/blue (+) – Ground (-)**

Turn the ignition switch ON and engine stop switch "O". Check the initial voltage at this time. Battery voltage should be measured. If the initial voltage cannot be measured, follow the checks in the troubleshooting table (page 5-5).

Squeeze the brake lever and retract the sidestand. Crank the engine with the starter and measure the ignition coil primary peak voltage.

**PEAK VOLTAGE: 100 V minimum**

If the peak voltage is lower than the 100 V, follow the checks in the troubleshooting table (page 5-5).

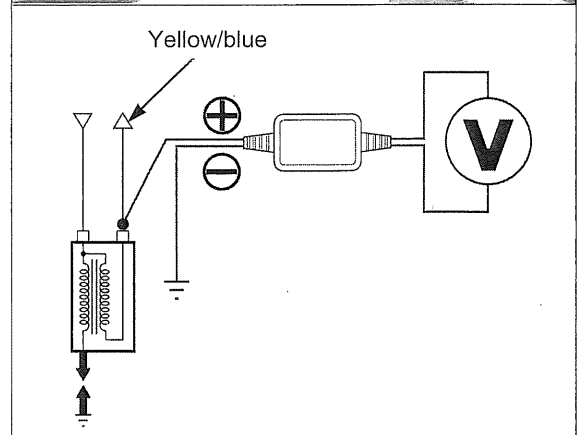
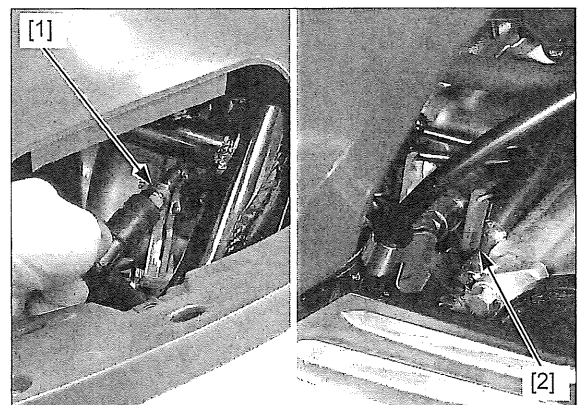

## IGNITION COIL

### REMOVAL/INSTALLATION

Remove the left side cover (page 2-8).

Disconnect the spark plug cap.  
Release the wire band boss [1].

Disconnect the ignition coil wire connectors [2]/[3].

Remove the mount bolts [4] and ignition coil [5].

Installation is in the reverse order of removal.

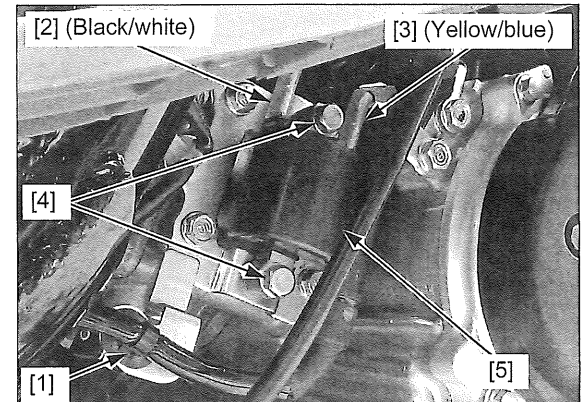

## IGNITION TIMING

- The ignition timing cannot be adjusted since the ECM is factory preset.

*It is not necessary to disconnect the water hoses from the radiator.*

Remove the four radiator mounting bolts and move it so that the cooling fan is visible (page 9-7).

Start the engine, warm it up to normal operating temperature and stop it.

- Never allow the cooling fan to come in contact with the radiator while the engine is running, or the radiator will be severely damaged.

*Read the instructions for timing light operation.*

Connect the timing light [1] to the spark plug wire.

Start the engine and let it idle ( $1,700 \pm 100$  rpm).

The ignition timing is correct if the index mark [2] on the radiator base aligns with the "F" mark [3] on the cooling fan.

If the ignition timing is incorrect, replace the ECM with a new one (page 4-49) and recheck.

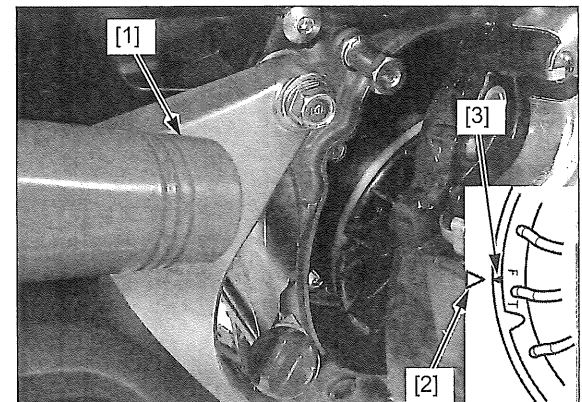

---

MEMO

---



# 6. ELECTRIC STARTER

---

SYSTEM LOCATION .....	6-2	STARTER/CHARGING RELAY .....	6-8
SYSTEM DIAGRAM .....	6-3	STARTER SYSTEM INSPECTION .....	6-11
SERVICE INFORMATION.....	6-4	SIDESTAND SWITCH.....	6-13
TROUBLESHOOTING .....	6-5		

# ELECTRIC STARTER

## SYSTEM LOCATION

'13 model:

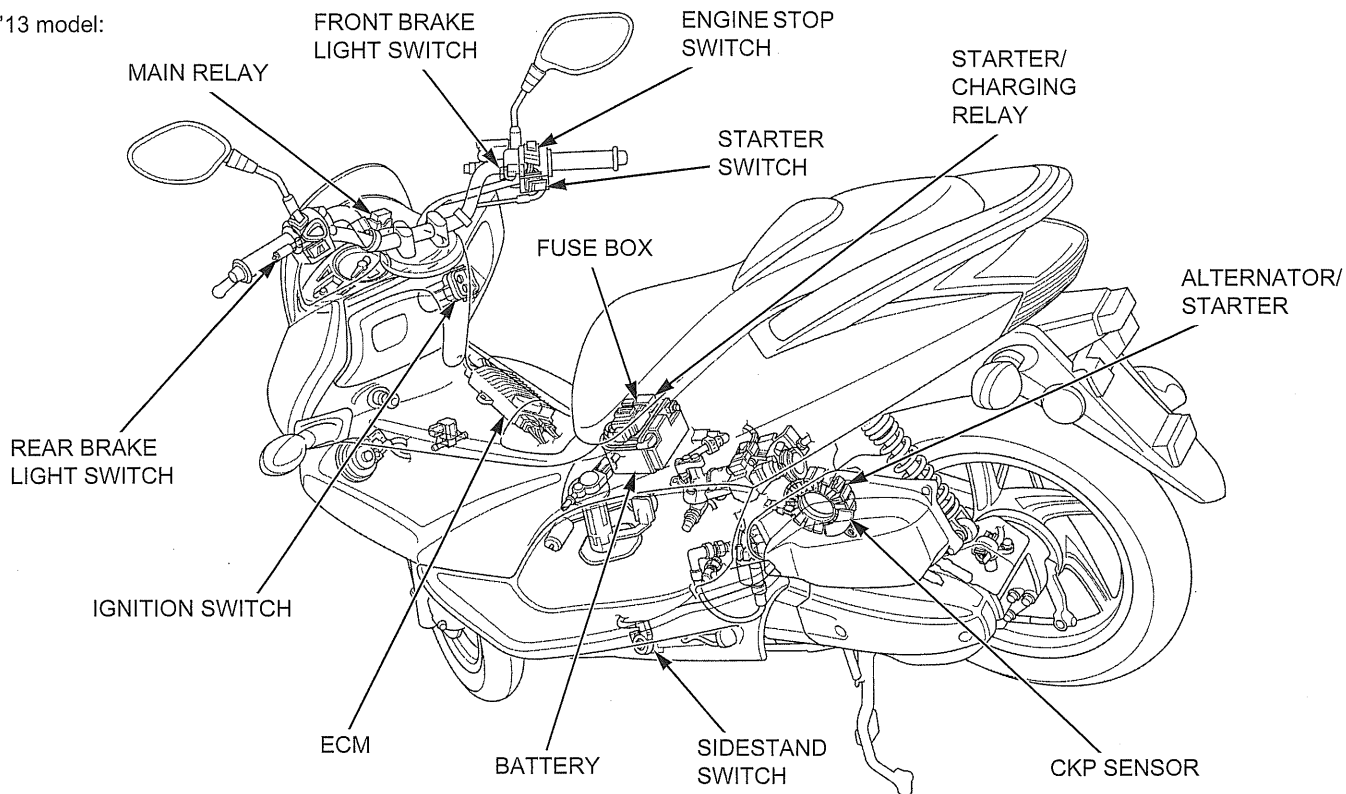

After '13 model:

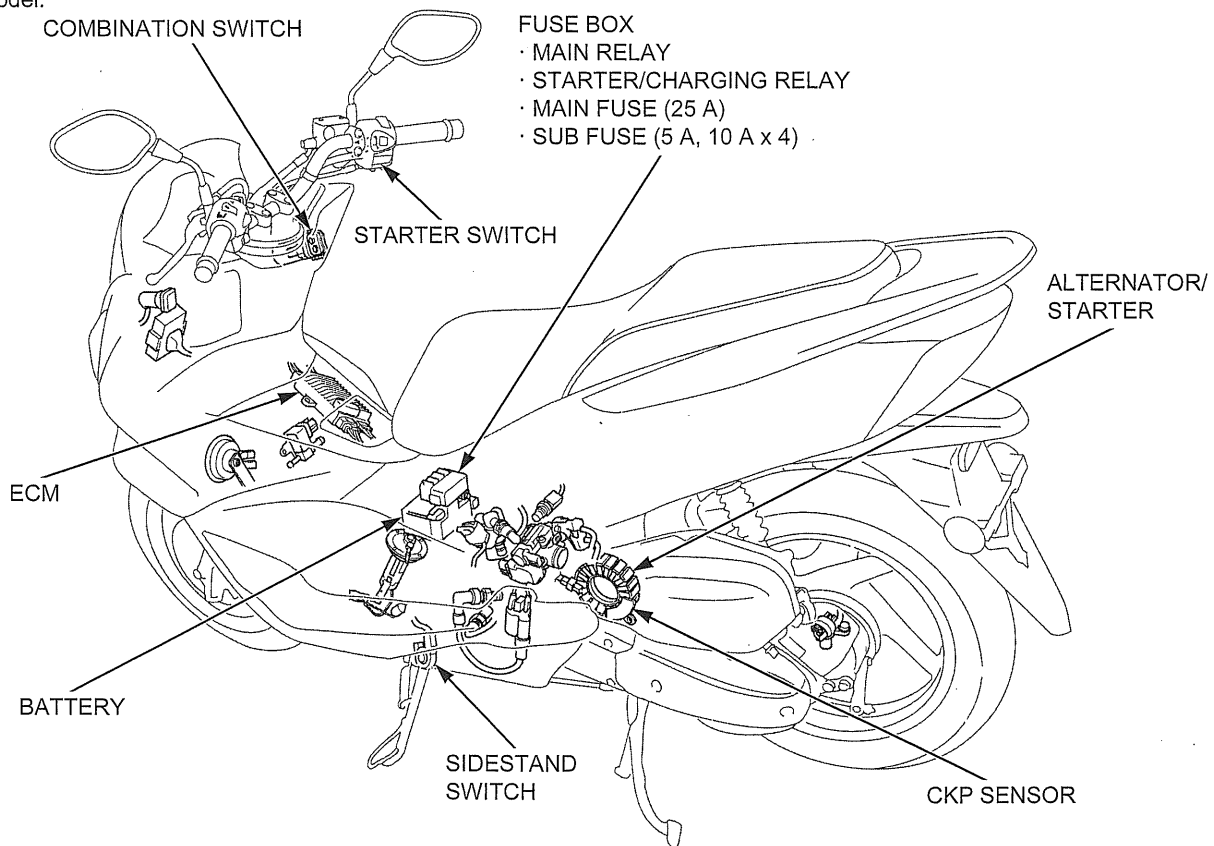

SYSTEM DIAGRAM

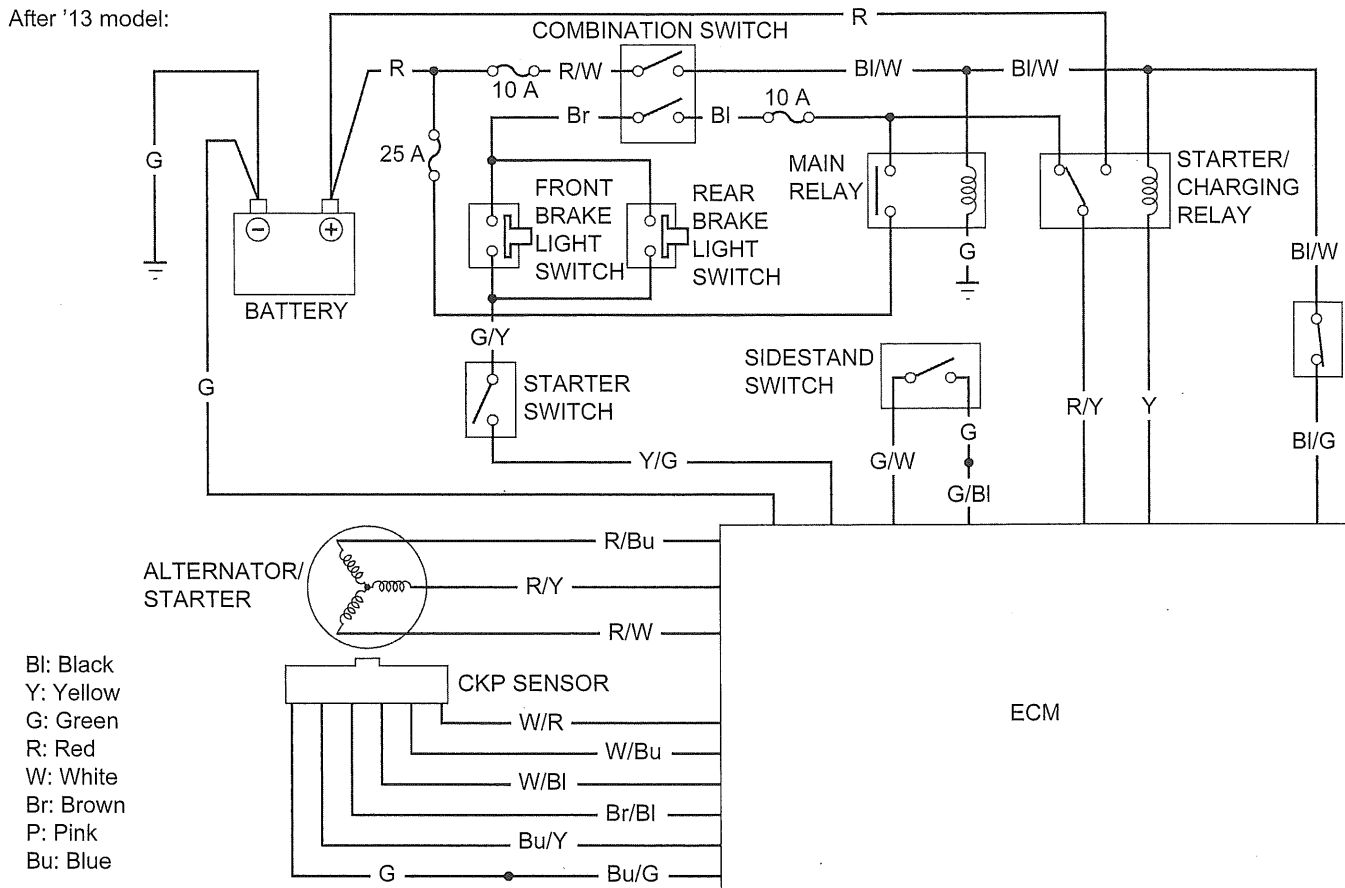
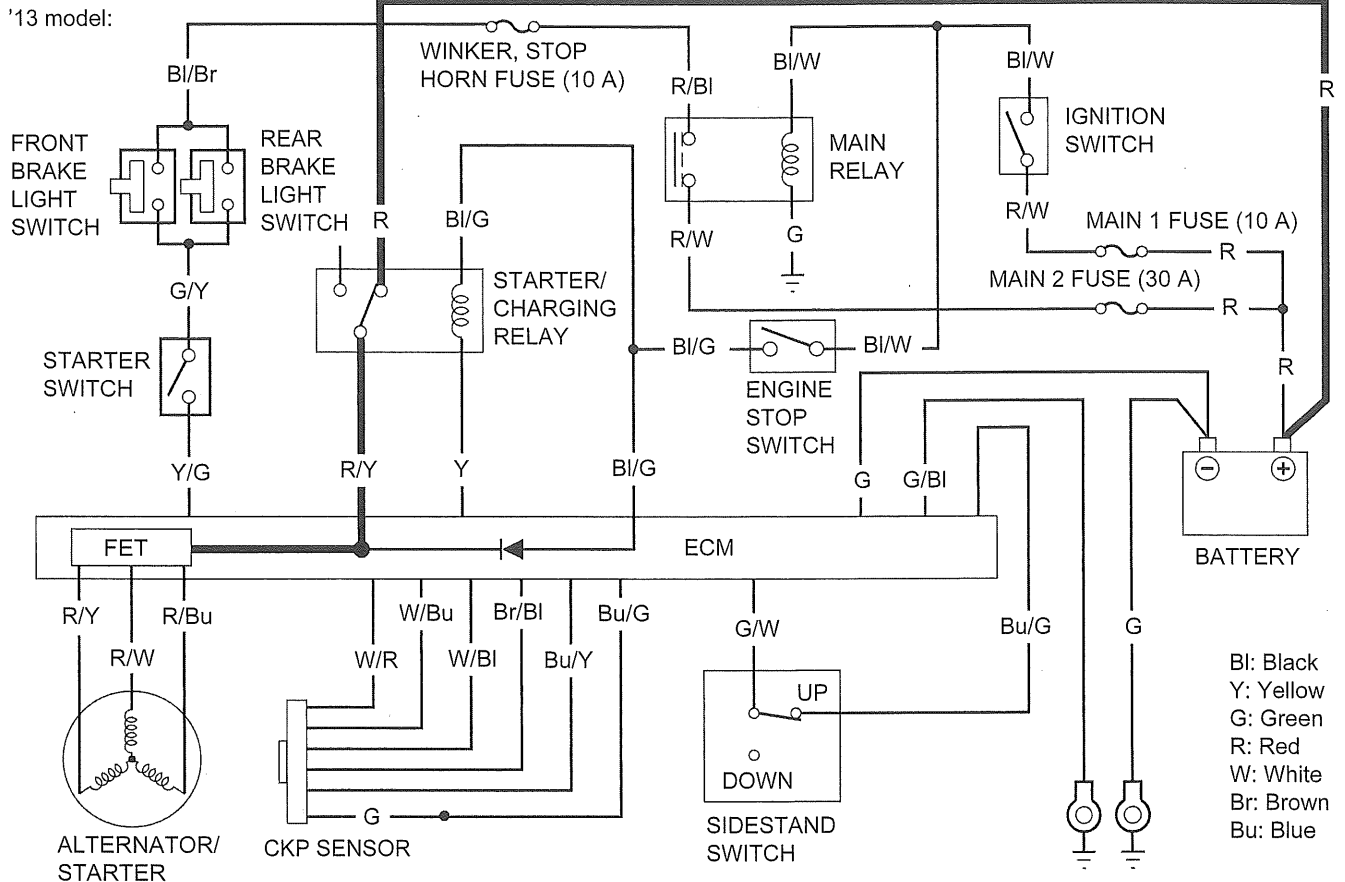

## ELECTRIC STARTER

# SERVICE INFORMATION

### GENERAL

- Some electrical components may be damaged if terminals or connectors are connected or disconnected while the ignition switch is turned ON and current is present.
- A weak battery may be unable to turn the alternator/starter quickly enough, or supply adequate ignition current.
- This scooter has adopted an alternator/starter that functions like both an alternator and starter.
- When checking the starter system, always follow the steps in the troubleshooting (page 6-5).
- If the current is kept flowing through the alternator/starter to turn it while the engine is not cranking over, the alternator/starter may be damaged.
- Refer to the following component information.
  - Ignition switch (page 21-21)
  - Brake light switch (page 21-25)
  - Starter switch (page 21-24)
- Refer to the alternator/starter removal/installation (page 14-4).

### TORQUE VALUE

ITEM	Q'TY	THREAD DIA. (mm)	TORQUE N·m (kgf·m, lbf·ft)	REMARKS
Sidestand switch bolt	1	6	10 (1.0, 7)	ALOC bolt: replace a with new one.

### TOOL

Test probe, 2 pack  
07ZAJ-RDJA110

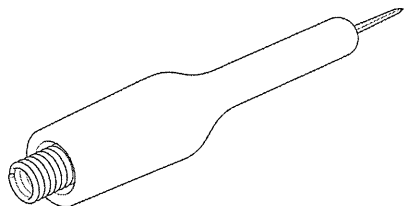

## TROUBLESHOOTING

### Alternator/starter does not turn

#### 1. Standard inspection

Check the following:

- Battery condition
- Burned fuses

**Are the above items in good condition?**

**YES** – GO TO STEP 2.

**NO** – Replace or repair the malfunctioning part(s).

#### 2. PGM-FI system inspection

Check the MIL blinks.

**Does the MIL blink?**

**YES** – Inspect the PGM-FI system (page 4-50).

**NO (MIL does not come on)** – Inspect the PGM-FI power/ground line (page 4-47).

**NO (MIL stay on a few second then go off)** –GO TO STEP 3.

#### 3. Starter Switch Line Inspection

Turn the ignition switch OFF.

Disconnect the ECM 21P (Gray) connector.

Turn the ignition switch ON and engine stop switch "O".

Squeeze the brake lever and push the starter switch.

Measure the battery voltage between the ECM 21P (Gray) connector and ground.

**CONNECTION: Yellow/green (+) – Ground (-)**

**Does the battery voltage exist?**

**YES** – GO TO STEP 4.

- NO** –
- Loose or poorly connected connector.
  - Open circuit in the Black/brown wire between the fuse box and front or rear brake light switch.
  - Faulty front or rear brake light switch (page 21-25).
  - Open circuit in the Green/yellow wire between the front or rear brake light switch and starter switch.
  - Open circuit in the Yellow/green wire between the starter switch and ECM.
  - Faulty starter switch (page 21-24).

#### 4. Sidestand Inspection

Turn the ignition switch OFF.

Retract the sidestand and check for continuity between the ECM 21P (Gray) connector and ground.

**CONNECTION: Green/white – Ground**

**Is there continuity?**

**YES** – GO TO STEP 5.

- NO** –
- Loose or poorly connected connector.
  - Open circuit in the Green/white wire between the ECM and sidestand switch.
  - Open circuit in the Blue/green wire between the sidestand switch and ECM.
  - Faulty sidestand switch.

#### 5. Starter/charging relay operation

Turn the ignition switch ON.

Retract the sidestand.

Squeeze the brake lever and push the starter switch.

You should hear the relay "CLICK" when the starter switch is depressed.

**Is the "CLICK" heard?**

**YES** – GO TO STEP 6.

**NO** – GO TO STEP 9.

## ELECTRIC STARTER

---

### 6. Starter/charging Relay Switch Line Inspection

Turn the ignition switch OFF.  
Disconnect the ECM 5P connector.

Turn the ignition switch ON.  
Retract the sidestand.  
Squeeze the brake lever and push the starter switch.  
Measure the battery voltage between the ECM 5P connector and ground.

**CONNECTION: Red/yellow (+) – Ground (–)**

*Does the battery voltage exist?*

**YES** – GO TO STEP 7.

**NO** –

- Loose or poorly connected connector.
- Open circuit in the Red/yellow wire between the starter/charging relay and ECM.
- Open circuit in the Red wire between the starter/charging relay and battery.
- Faulty starter/charging relay (Inspect the starter/charging relay: page 6-8)

### 7. Stator Coil Circuit Inspection

Turn the ignition switch OFF.  
Disconnect the ECM 3P (Black) connector.  
Measure the resistance at the ECM 3P (Black) connector.

**CONNECTION: Red/yellow – Red/white**  
**Red/yellow – Red/blue**  
**Red/white – Red/blue**

*Is the resistance within 0.03 – 0.20  $\Omega$  (20 °C/68 °F)?*

**YES** – GO TO STEP 8.

**NO** – Replace the alternator/starter with a new one and recheck.

### 8. CKP Sensor Circuit Inspection

Turn the ignition switch OFF.  
Disconnect the CKP sensor 6P (Black) connector.  
Turn the ignition switch ON.  
Measure the voltage at the 6P (Black) connector of the ECM side and ground.

**CONNECTION: White/red (+) – Ground (–)**  
**White/blue (+) – Ground (–)**  
**White/black (+) – Ground (–)**  
**Blue/yellow (+) – Ground (–)**

**STANDARD: 5 – 10 V**

Measure the voltage at the 6P (Black) connector of the ECM side.

**CONNECTION: Brown/black (+) – Blue/green (–)**  
**STANDARD: Battery voltage**

*Does the standard voltage exist?*

**YES** – Replace the CKP sensor with a new one and recheck.

**NO** –

- Open circuit in the wire harness between the ECM and CKP sensor connector
- Replace the ECM with a new one and recheck.

### 9. Starter/charging Relay Continuity Inspection

Remove the starter/charging relay (page 6-8).  
Check the starter/charging relay operation (page 6-8).

*Is the operation normal?*

**YES** – GO TO STEP 10.

**NO** – Faulty starter/charging relay

## 10. Starter/charging Relay Coil Line Inspection

Turn the ignition switch OFF.  
Install the starter/charging relay (page 6-8).  
Disconnect the ECM 21P (Black) connector.

Turn the ignition switch ON.  
Measure the battery voltage between the ECM 21P (Black) connector and ground.

**CONNECTION: Yellow (+) – Ground (-)**

### *Does battery voltage exist?*

**YES** – Replace the ECM with a new one and recheck.

**NO** –

- Loose or poorly connected connector.
- Open circuit in the Black/white wire between the ignition switch and engine stop switch.
- Open circuit in the Black/green wire between the engine stop switch and starter/charging relay.
- Open circuit in the Yellow wire between the starter/charging relay and ECM.
- Faulty engine stop switch (page 21-24).

### **Alternator/starter turns engine slowly**

- Low battery voltage.
- Poorly connected battery terminal cable.
- Crankshaft slowly turn due to engine problems.
- Poor connected battery ground cable.

### **Starter/charging relay "CLICK", but engine does not turn**

- Crankshaft does not turn due to engine problems.

## ELECTRIC STARTER

### STARTER/CHARGING RELAY

#### REMOVAL/INSTALLATION ('13 MODEL)

Remove the battery maintenance lid (page 20-7).

Pull the starter/charging relay [1] and disconnect it from the 5P (Black) connector [2].

Installation is in the reverse order of removal.

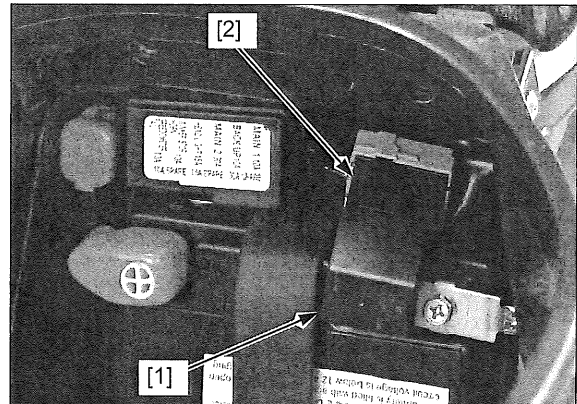

#### REMOVAL/INSTALLATION (AFTER '13 MODEL)

Remove the battery maintenance lid (page 20-7).

Remove the fuse box cover [1] and starter/charging relay [2].

Installation is in the reverse order of removal.

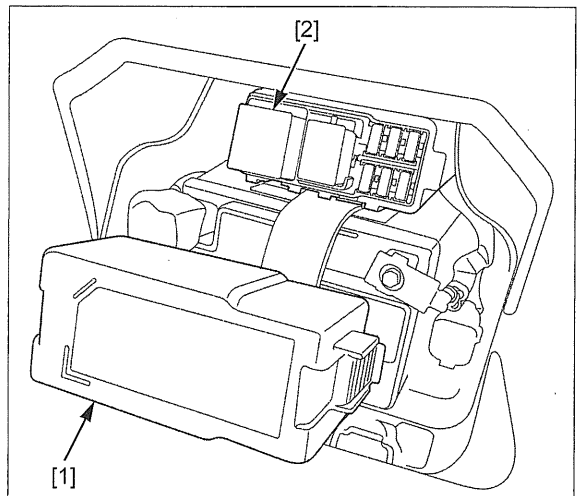

#### OPERATION INSPECTION

Remove the battery maintenance lid (page 20-7).

Turn the ignition switch ON and engine stop switch "O". Retract the sidestand.

Squeeze the brake lever and push the starter switch. The system is normal if the starter/charging relay [1] clicks.

If you hear the relay "CLICK", but the starter does not turn, inspect the following:

- Relay switch line (page 6-9)
- Stator (page 6-11)
- CKP sensor line (page 6-11)
- ECM power/ground line (page 4-50)

If you don't hear the relay "CLICK", inspect the following:

- Starter switch line (page 6-12)
- Starter/charging relay switch continuity (page 6-10)
- Relay coil line (page 6-9)
- Sidestand switch line (page 6-13)

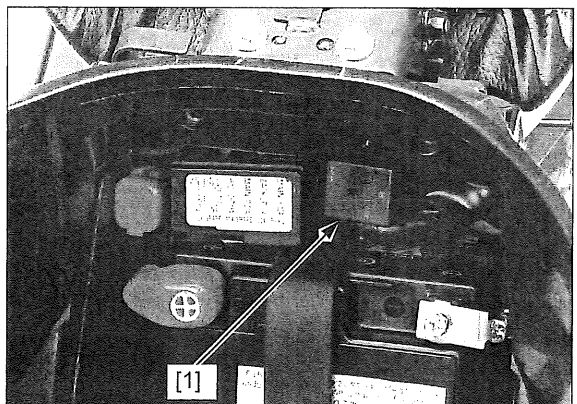



**RELAY SWITCH LINE INSPECTION**

Disconnect the ECM 5P connector (page 4-49).

Turn the ignition switch ON and engine stop switch "O". Squeeze the rear brake lever and push the starter switch.

Measure the voltage between the ECM 5P connector [1] of the wire harness side and ground.

**CONNECTION:** Red/yellow (+) – ground (-)

**STANDARD:** Battery voltage

If there is battery voltage, the relay switch line is normal.

If there is no voltage, inspect the following:

- Loose or poor contacts of related terminal
- Open circuit in the Red wire between the battery and starter/charging relay
- Open circuit in the Red/yellow wire between the starter/charging relay and ECM

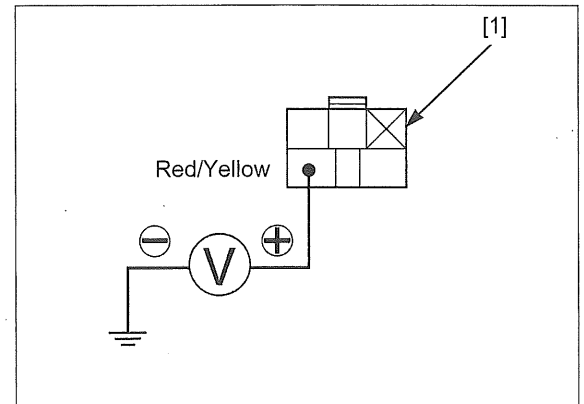
**RELAY COIL LINE INSPECTION ('13 MODEL)**

Disconnect the ECM 21P (Black) connector (page 4-49).

Turn the ignition switch ON and engine stop switch "O". Squeeze the rear brake lever and push the starter switch.

Measure the voltage between the ECM 21P (Black) connector [1] of the wire harness side and ground.

**TOOL:**

**Test probe, 2 pack**                      **07ZAJ-RDJA110**

**CONNECTION:** Yellow (+) – ground (-)

**STANDARD:** Battery voltage

If there is battery voltage, the relay coil line is normal.

If there is no voltage, inspect the following:

- Loose or poorly connected connector
- Open circuit in the Black/white wire between the ignition switch and engine stop switch
- Open circuit in the Black/green wire between the engine stop switch and starter/charging relay
- Open circuit in the Yellow wire between the starter/charging relay and ECM

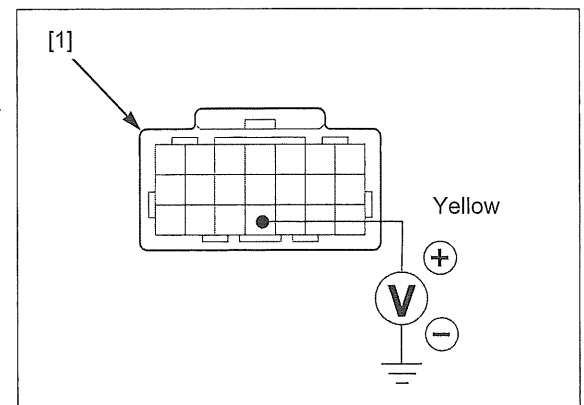

## ELECTRIC STARTER

### RELAY COIL LINE INSPECTION (AFTER '13 MODEL)

Disconnect the ECM 33P (Black) connector (page 4-49).

Turn the ignition switch ON.

Squeeze the rear brake lever fully and push the starter switch.

Measure the voltage between the ECM 33P (Black) connector [1] of the wire harness side and ground.

**TOOL:**

**Test probe, 2 pack**

**07ZAJ-RDJA110**

**CONNECTION: Yellow (+) – ground (-)**

**STANDARD: Battery voltage**

If there is battery voltage, the relay coil line is normal.  
If there is no voltage, inspect the following:

- Loose or poorly connected connector
- Open circuit in the Black/white wire between the ignition switch and starter/charging relay
- Open circuit in the Yellow wire between the starter/charging relay and ECM

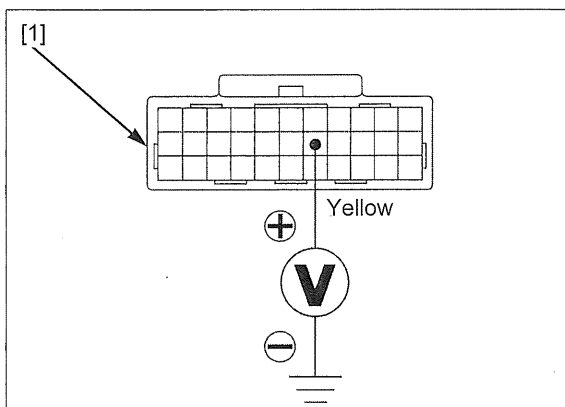

### CONTINUITY INSPECTION

Remove the starter/charging relay (page 6-8).

Connect an ohmmeter to the following relay [1] connector terminals.

**CONNECTION: A – C**

Connect a 12 V battery to the following relay connector terminals.

**CONNECTION: D – E**

There should be continuity when the battery is connected and there should be no continuity when the battery is disconnected.

If the above inspection is abnormal, replace the starter/charging relay.

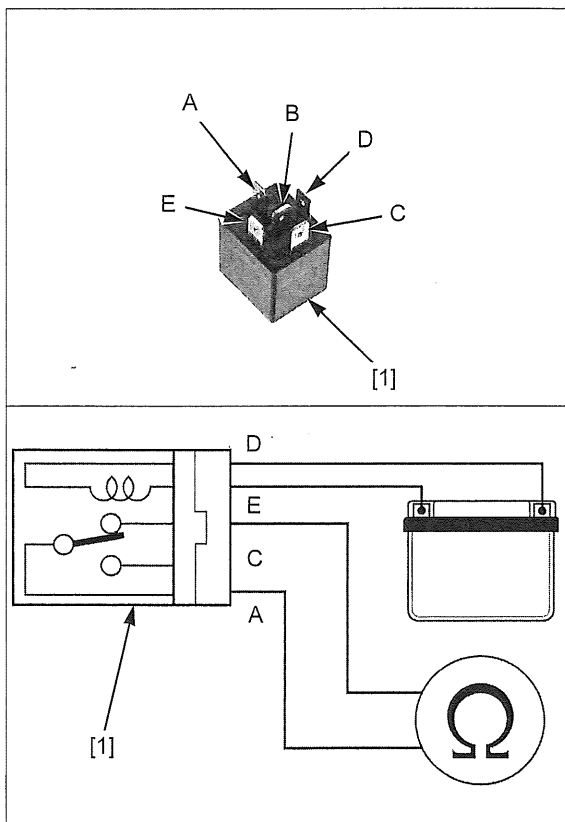

## STARTER SYSTEM INSPECTION

### CKP SENSOR LINE INSPECTION

Remove the luggage box (page 2-25).

Disconnect the CKP sensor 6P (Black) connector [1].

Turn the ignition switch ON and engine stop switch "O". Measure the voltage between the CKP sensor 6P (Black) connector of the ECM side and ground.

**CONNECTION:** White/red (+) – ground (-)  
 White/blue (+) – ground (-)  
 White/black (+) – ground (-)  
 Blue/yellow (+) – ground (-)

**STANDARD:** 5 – 10 V

Measure the voltage between the CKP sensor 6P (Black) connector of the ECM side.

**CONNECTION:** Brown/black (+) – Blue/green (-)

**STANDARD:** Battery voltage

If there is standard voltage, the CKP sensor lines are normal.

If there is no voltage, inspect the following:

- Loose or poor contacts of related terminal
- Open circuit in the wire harness between the ECM and CKP sensor connector
- Faulty ECM

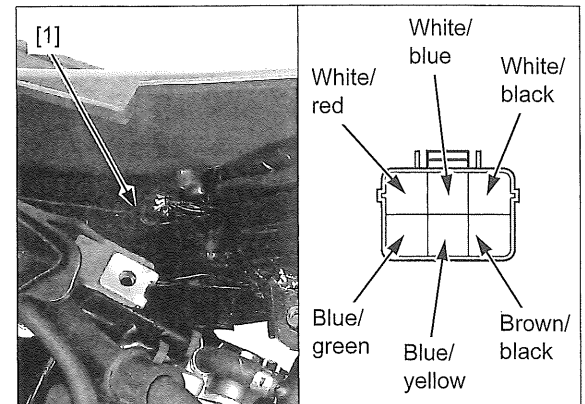

### STATOR INSPECTION

Disconnect the ECM 3P (Black) connector (page 4-49).

Measure the resistance at the ECM 3P (Black) connector [1].

**CONNECTION:** Red/yellow – Red/white  
 Red/yellow – Red/blue  
 Red/white – Red/blue

**STANDARD:** 0.03 – 0.20  $\Omega$  (20 °C/68 °F)

If there is standard value, stator is normal.

If the value is abnormal at any connection, inspect the following:

- Loose or poor contacts of related terminal
- Open circuit in the wire harness between the ECM and stator

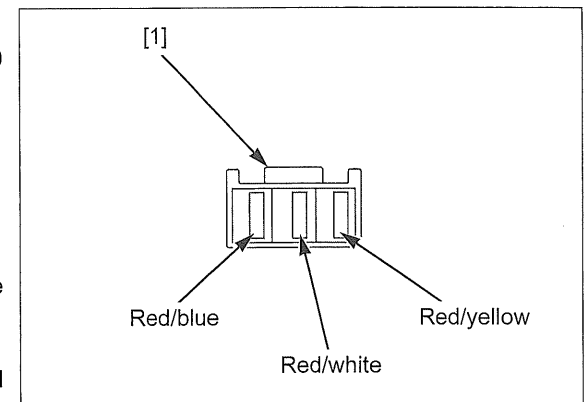

## STARTER SWITCH LINE INSPECTION ( '13 MODEL)

Disconnect the ECM 21P (Gray) connector (page 4-49).

Turn the ignition switch ON and engine stop switch "O". Squeeze the brake lever and push the starter switch. Measure the voltage between the ECM 21P (Gray) connector [1] of the wire harness side and ground.

**TOOL:**

Test probe, 2 pack                      07ZAJ-RDJA110

**CONNECTION:** Yellow/green (+) – ground (-)

**STANDARD:** Battery voltage

If there is battery voltage, the switch line is normal.

If there is no voltage, inspect the following:

- Loose or poorly connected connector
- Open circuit in the Black/brown wire between the fuse box and front or rear brake light switch
- Faulty front or rear brake light switch (page 21-25)
- Open circuit in the Green/yellow wire between the front or rear brake light switch and starter switch
- Open circuit in the Yellow/green wire between the starter switch and ECM
- Faulty starter switch (page 21-24)

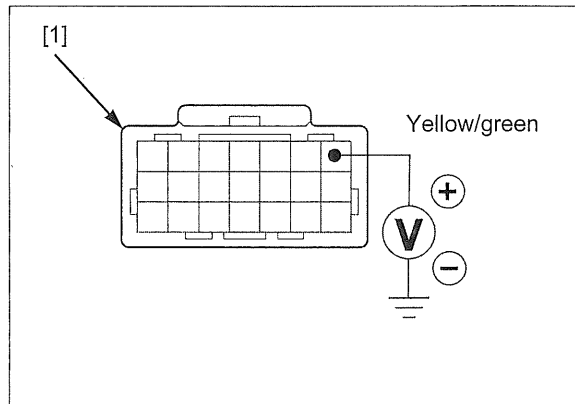

## STARTER SWITCH LINE INSPECTION (AFTER '13 MODEL)

Disconnect the ECM 33P (Black) connector (page 4-49).

Turn the ignition switch ON. Squeeze the rear brake lever fully and push the starter switch. Measure the voltage between the ECM 33P (Black) connector [1] of the wire harness side and ground.

**TOOL:**

Test probe, 2 pack                      07ZAJ-RDJA110

**CONNECTION:** Yellow/green (+) – ground (-)

**STANDARD:** Battery voltage

If there is battery voltage, the switch line is normal.

If there is no voltage, inspect the following:

- Loose or poorly connected connector
- Open circuit in the Black wire between the fuse box and combination switch
- Open circuit in the Brown wire between the combination switch and front or rear brake light switch
- Faulty combination switch
- Faulty front or rear brake light switch (page 21-25)
- Open circuit in the Green/yellow wire between the front or rear brake light switch and starter switch
- Open circuit in the Yellow/green wire between the starter switch and ECM
- Faulty starter switch (page 21-24)

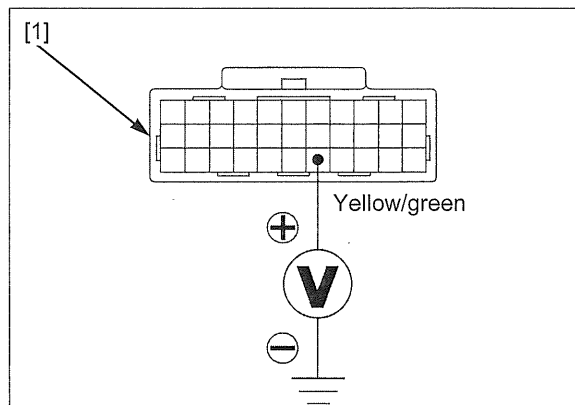

## SIDESTAND SWITCH

### REMOVAL/INSTALLATION

Remove the left floor step (page 2-19).

Disconnect the sidestand switch 3P (Green) connector [1].

Release the wire [2] from the wire clamps [3].

Release the wire band boss [4].

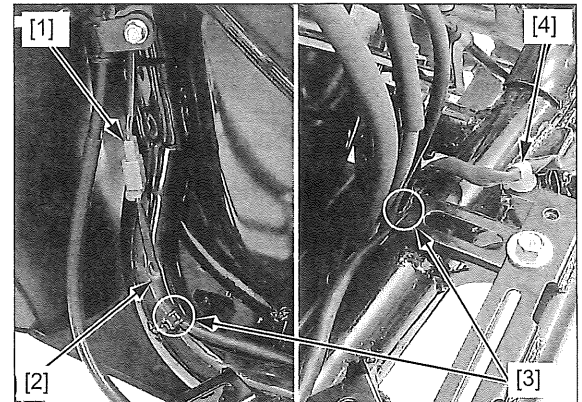

Remove the bolt [1] and sidestand switch [2].

Installation is in the reverse order of removal.

- Install the sidestand switch while aligning its groove with the spring pin.
- When installing the sidestand switch bolt, replace it with a new one and tighten it to the specified torque.

#### TORQUE:

Sidestand switch bolt: 10 N·m (1.0 kgf·m, 7 lbf·ft)

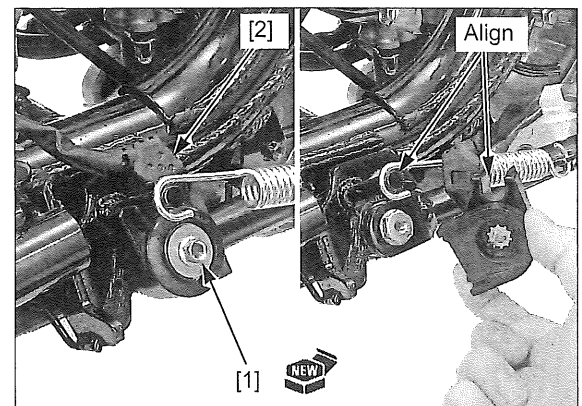

### INSPECTION ('13 MODEL)

Disconnect the ECM 21P (Gray) connector (page 4-49).

Check for continuity between the following terminals of the ECM 21P (Gray) connector [1] of the wire harness side.

#### TOOL:

Test probe, 2 pack                      07ZAJ-RDJA110

#### CONNECTION: Green/white – Blue/green

There should be continuity with the sidestand retracted, and there should be no continuity with the sidestand applied.

If there is no continuity with the sidestand retracted, the wire harness is broken or the sidestand switch is faulty.

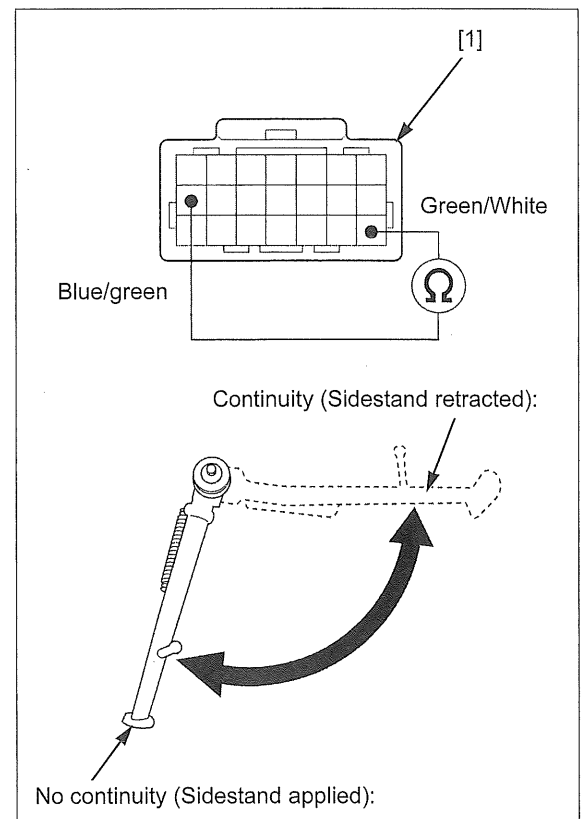

## ELECTRIC STARTER

### INSPECTION (AFTER '13 MODEL)

Disconnect the ECM 33P (Black) connector (page 4-49).

Check for continuity between the following terminals of the ECM 33P (Black) connector [1] of the wire harness side.

**TOOL:**

Test probe, 2 pack

07ZAJ-RDJA110

**CONNECTION: A31 – A23**

There should be continuity with the sidestand retracted, and there should be no continuity with the sidestand applied.

If there is no continuity with the sidestand retracted, the wire harness is broken or the sidestand switch is faulty.

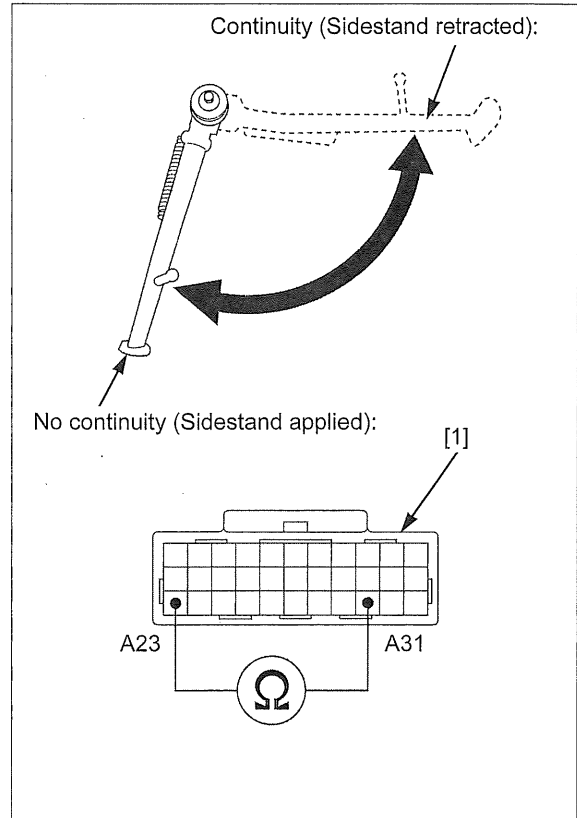

# 7. FUEL SYSTEM

---

COMPONENT LOCATION .....	7-2	THROTTLE BODY .....	7-15
SERVICE INFORMATION .....	7-4	IACV .....	7-22
FUEL LINE INSPECTION .....	7-6	FUEL INJECTOR .....	7-24
FUEL SUPPLY TEST (AFTER '13 MODEL) .....	7-9	INTAKE PIPE .....	7-25
FUEL PUMP UNIT .....	7-10	EVAP PURGE CONTROL SOLENOID VALVE (EXCEPT AFTER '13 MODEL CM TYPE) .....	7-27
FUEL TANK .....	7-13	EVAP CANISTER (EXCEPT AFTER '13 MODEL CM TYPE) .....	7-28
AIR CLEANER HOUSING .....	7-13		

# FUEL SYSTEM

## COMPONENT LOCATION

'13 model:

12 N·m (1.2 kgf·m, 9 lbf·ft)

3.5 N·m (0.36 kgf·m, 2.6 lbf·ft)

11 N·m (1.1 kgf·m, 8 lbf·ft)

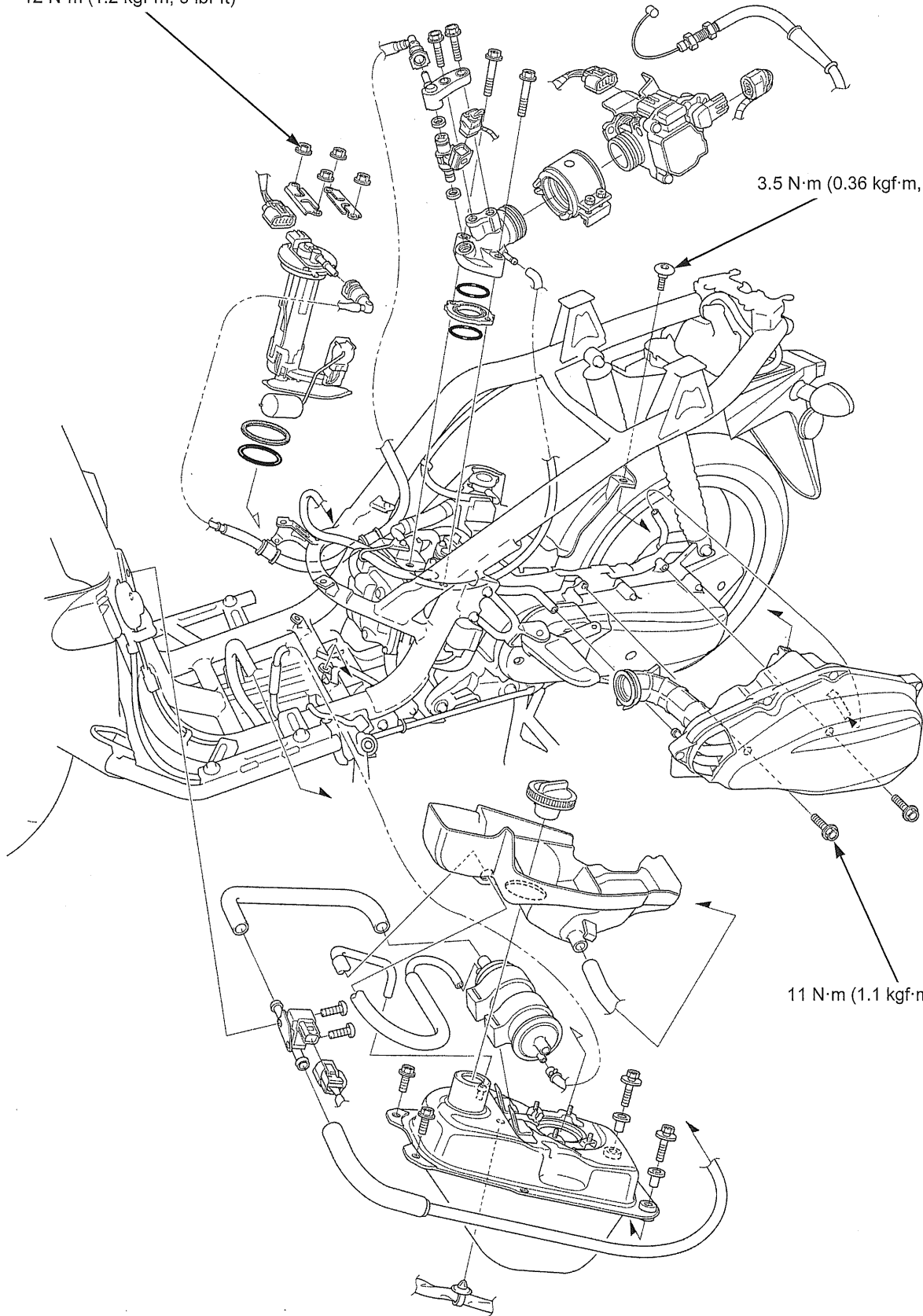



After '13 model:  
AC type shown:

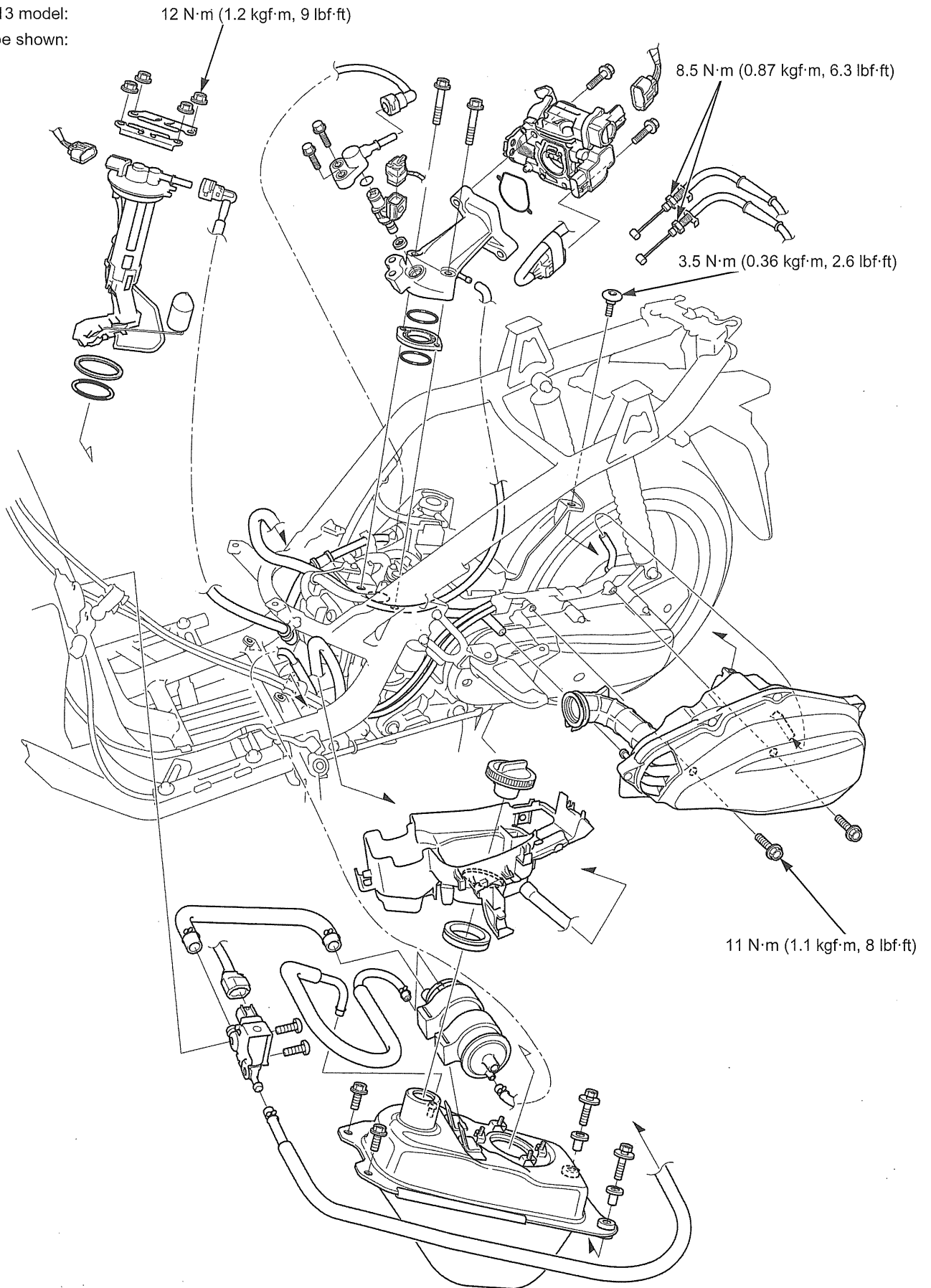

## FUEL SYSTEM

# SERVICE INFORMATION

## GENERAL

- Bending or twisting the control cable will impair smooth operation and could cause the cables to stick or bind, resulting in loss of vehicle control.
- Work in a well ventilated area. Smoking or allowing flames or sparks in the work area or where gasoline is stored can cause a fire or explosion.
- When disassembling fuel system parts, note the locations of the O-rings. Replace them with new ones upon reassembly.
- Before disconnecting the fuel feed hose, relieve fuel pressure from the system (page 7-6).
- Do not snap the throttle valve from full open to full close after the throttle cable has been removed. It may cause incorrect idle operation.
- Seal the intake ports with tape or a clean cloth to keep dirt and debris from entering the engine after the throttle body has been removed.
- Do not damage the throttle body. It may cause incorrect throttle valve operation.
- Prevent dirt and debris from entering the throttle bore and air passages after the throttle body has been removed. Clean them using a compressed air if necessary.
- Do not loosen or tighten the white painted nut and screw of the throttle body. Loosening or tightening them can cause throttle valve and idle control failure.
- The parts of the throttle body not shown in this manual should not be disassembled.
- For fuel level sensor inspection (page 21-19).



## SPECIFICATIONS

ITEM		SPECIFICATIONS
Throttle body identification number	'13 model	GQMHA
	After '13 model	GQMNA
Throttle grip freeplay		2 – 6 mm (0.1 – 0.2 in)
Fuel pressure at idle	'13 model	294 kPa (3.0 kgf/cm <sup>2</sup> , 43 psi)
	After '13 model	263 – 316 kPa (2.7 – 3.2 kgf/cm <sup>2</sup> , 38 – 46 psi)
Fuel pump flow (at 12 V)	'13 model	98 cm <sup>3</sup> (3.31 US oz, 3.45 Imp oz) minimum/10 seconds
	After '13 model	82 cm <sup>3</sup> (2.77 US oz, 2.89 Imp oz) minimum/10 seconds

## TORQUE VALUES

ITEM	Q'TY	THREAD DIA. (mm)	TORQUE N·m (kgf·m, lbf·ft)	REMARKS
Fuel pump set plate nut	4	6	12 (1.2, 9)	For tightening sequence; See page 7-12
Air cleaner housing mounting bolt	2	6	11 (1.1, 8)	
Rear inner fender socket bolt - Air cleaner side	1	6	3.5 (0.36, 2.6)	
Sensor unit torx screw ('13 model)	3	5	3.4 (0.35, 2.5)	
Sensor unit mounting screw ('After 13 model)	2	4	2.1 (0.21, 1.5)	
Throttle cable bracket mounting screw ('13 model)	1	5	3.4 (0.35, 2.5)	
Throttle cable bracket mounting bolt (After '13 model)	1	5	3.4 (0.35, 2.5)	
Throttle cable adjust lock nut (After '13 model)	1	7	3.8 (0.39, 2.8)	
Throttle cable nut (throttle body side) (After '13 model)	2	8	8.5 (0.87, 6.3)	See page 7-15
IACV torx screw ('13 model)	2	4	2.1 (0.21, 1.5)	
IACV screw (After '13 model)	3	4	2.1 (0.21, 1.5)	
Insulator band bolt	2	5	5 (0.51, 3.7)	

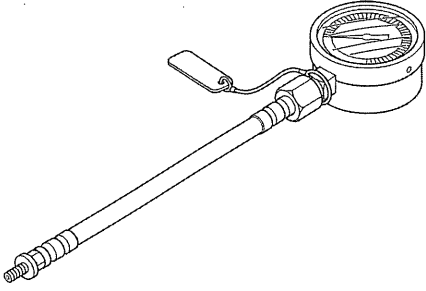
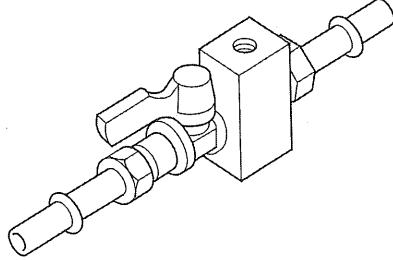
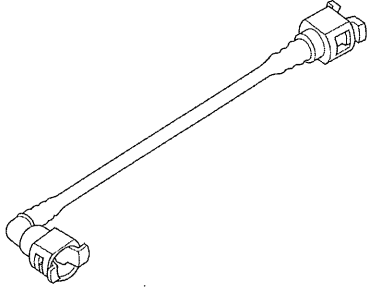
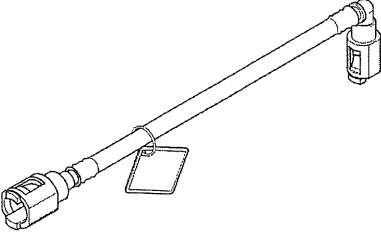
TOOLS

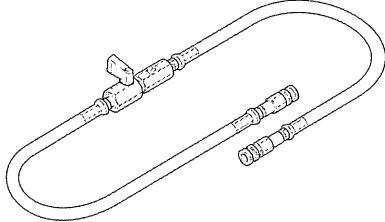
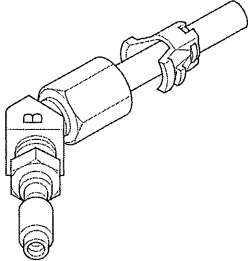
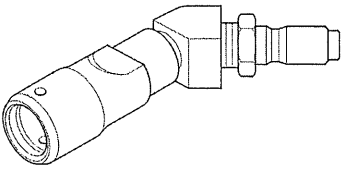
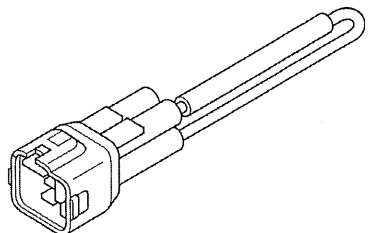
<p>Fuel pressure gauge 07406-0040004</p>  <p>or 07406-004000B (U.S.A. only)</p>	<p>Pressure gauge manifold 07ZAJ-S5A0111</p>  <p>(Not available in U.S.A.)</p>	<p>Hose attachment, 9 mm/9 mm 07ZAJ-S5A0120</p>  <p>(Not available in U.S.A.)</p>
<p>Hose attachment, 6 mm/9 mm 07ZAJ-S5A0130</p>  <p>(Not available in U.S.A.)</p>	<p>Attachment joint, 6 mm/9 mm 07ZAJ-S5A0150</p>  <p>(Not available in U.S.A.)</p>	<p>Pressure manifold hose 07AMJ-HW3A100 (U.S.A. only)</p> 
<p>Adaptor B, male 07AAJ-S6MA200 (U.S.A. only)</p> 	<p>Adaptor B, female 07AAJ-S6MA400 (U.S.A. only)</p> 	<p>SCS connector 070PZ-ZY30100</p> 

# FUEL LINE INSPECTION

### FUEL PRESSURE RELIEVING

**NOTE:**

Before disconnecting quick connect fitting, relieve pressure from the system by following the procedures below.

1. Remove the luggage box (page 2-25).
2. Turn the ignition switch OFF.  
Remove the two bolts [1] and pull up the battery box [2] as shown.  
Disconnect the fuel pump 5P connector [3].
3. Start the engine and let it idle until the engine stalls.
4. Turn the ignition switch OFF.
5. Remove the bolt [4] and disconnect the battery negative (-) cable [5].

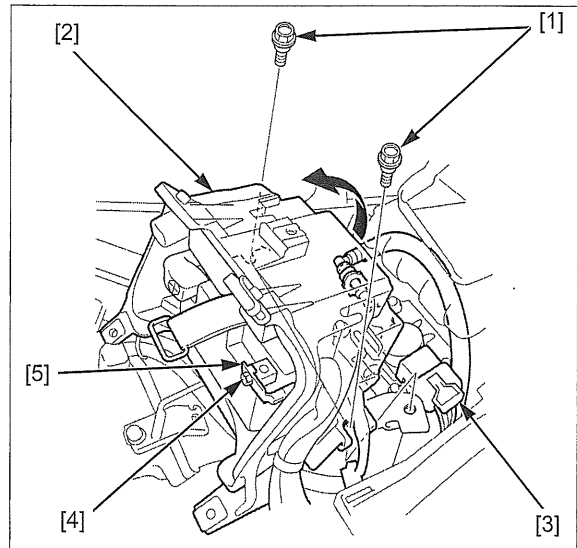

### QUICK CONNECT FITTING REMOVAL

**NOTE:**

- Before disconnecting fuel feed hose, relieve pressure from the system by following the procedures above.
  - This scooter uses resin for the part of materials in the fuel feed hose. Do not bend or twist the fuel feed hose.
1. Check the fuel quick connect fitting [1] for dirt, and clean if necessary.  
Place a shop towel over the quick connect fitting.  
Push the retainer tab [2] forward.

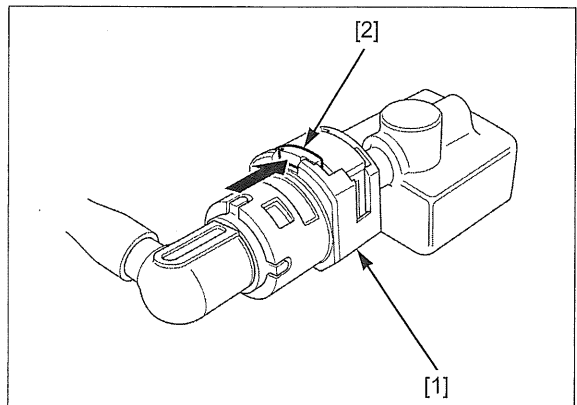

2. Press down the retainer [1] and hold.  
Disconnect the connector [2] from the fuel pump joint/fuel injector joint.  
Check the retainer condition and replace it if necessary.

**NOTE:**

- Prevent the remaining fuel in the fuel feed hose from flowing out using a shop towel.
- Be careful not to damage the hose or other parts.
- Do not use tools or chemicals to aid loosening.
- If the connector does not move, alternately pull and push the connector until it comes off easily.

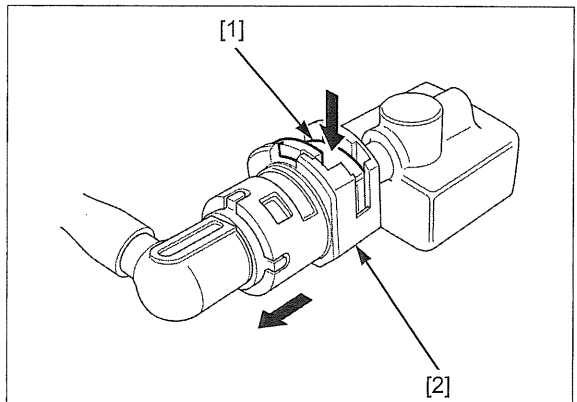

3. To prevent damage and keep foreign matter out, cover the disconnected connector and pipe end with plastic bags [1].

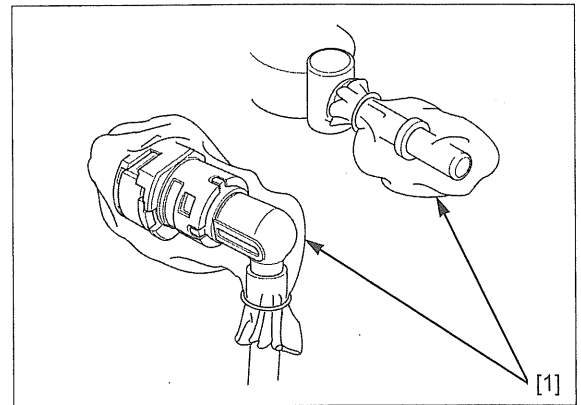

### QUICK CONNECT FITTING INSTALLATION

**NOTE:**

- Always replace the retainer with the same manufacturer's item that was removed.
- Do not bend or twist fuel feed hose.

1. Press the connector [1] onto the fuel pump joint/fuel injector joint until the retainer [2] locks with a "CLICK".

**NOTE:**

- Align the quick connect fitting with the pipe.  
If it is hard to connect, put a small amount of engine oil on the pipe end.

2. Make sure the connection is secure; check visually and by pulling the connector.

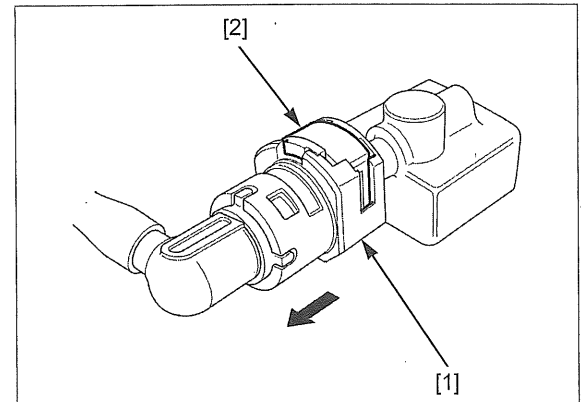

### FUEL PRESSURE NORMALIZATION

1. Connect the fuel pump 5P connector [1].
2. Set the battery box [2] in position, then install and tighten the two special bolts [3].
3. Connect the negative (-) cable [4] to the battery and tighten the bolt [5].
4. Turn the ignition switch ON and engine stop switch "O".

**NOTE:**

- Do not start the engine.
- The fuel pump will run for about 2 seconds, and fuel pressure will rise.  
Repeat 2 or 3 times, and check that there is no leakage in the fuel supply system.

5. Turn the ignition switch OFF.
6. Install the luggage box (page 2-25).

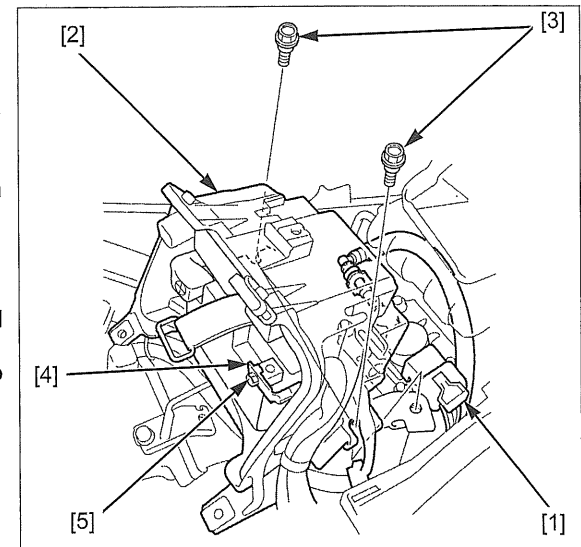

### FUEL PRESSURE TEST

Relieve the fuel pressure and disconnect the fuel pump side quick connect fitting (page 7-6).

Attach the fuel pressure gauge, attachments and manifold.

#### TOOLS:

[1] Fuel pressure gauge	07406-0040004
[2] Pressure gauge manifold	07ZAJ-S5A0111
[3] Hose attachment, 9 mm/9 mm	07ZAJ-S5A0120
[4] Hose attachment, 6 mm/9 mm	07ZAJ-S5A0130
[5] Attachment joint, 6 mm/9 mm	07ZAJ-S5A0150

#### U.S.A. tools:

Fuel pressure gauge	07406-004000B
Pressure manifold hose	07AMJ-HW3A100
Adaptor B, male	07AAJ-S6MA200
Adaptor B, female	07AAJ-S6MA400

Temporarily connect the positive cable and negative cable to the battery and fuel pump 5P connector.

Start the engine and let it idle.

Read the fuel pressure.

#### STANDARD:

'13 model: 294 kPa (3.0 kgf/cm<sup>2</sup>, 43 psi)

After '13 model: 263 – 316 kPa (2.7 – 3.2 kgf/cm<sup>2</sup>, 38 – 46 psi)

- If the fuel pressure is higher than specified, replace the fuel pump unit (page 7-10).
- If the fuel pressure is lower than specified, inspect the following:
  - Fuel line leaking (page 3-6)
  - Fuel pump unit (page 7-10)
  - Clogged fuel filter (page 7-10)

After inspection, relieve the fuel pressure (page 7-6).

Remove the fuel pressure gauge, attachment and manifold from the fuel pump.

Connect the fuel pump side quick connect fitting and normalize the fuel pressure (page 7-7).

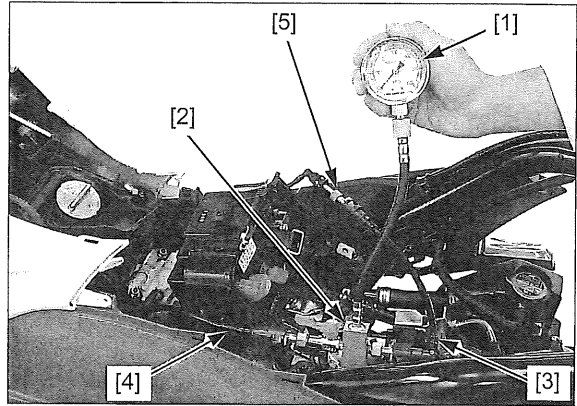

## FUEL FLOW INSPECTION

Relieve the fuel pressure and disconnect the fuel injector side quick connect fitting (page 7-6).

*Wipe up any spilled gasoline.*

Place the end of the hose into an approved gasoline container.

Temporarily connect the negative (-) cable [1] to the battery and fuel pump 5P connector.

Turn the ignition switch ON and engine stop switch "O". Measure the amount of fuel flow.

### NOTE:

- The fuel pump operates for 2 seconds. Repeat 5 times to meet the total measuring time.
- Return fuel to the fuel tank when the first fuel is finished.

### Amount of fuel flow:

'13 model: 98 cm<sup>3</sup> (3.31 US oz, 3.45 Imp oz)  
minimum/10 seconds

After '13 model: 82 cm<sup>3</sup> (2.77 US oz, 2.89 Imp oz)  
minimum/10 seconds

If fuel flow is less than specified, inspect the following:

- Clogged fuel hose
- Fuel pump unit (page 7-10)
- Clogged fuel filter (page 7-10)

Connect the quick connect fitting and normalize the fuel pressure (page 7-7).

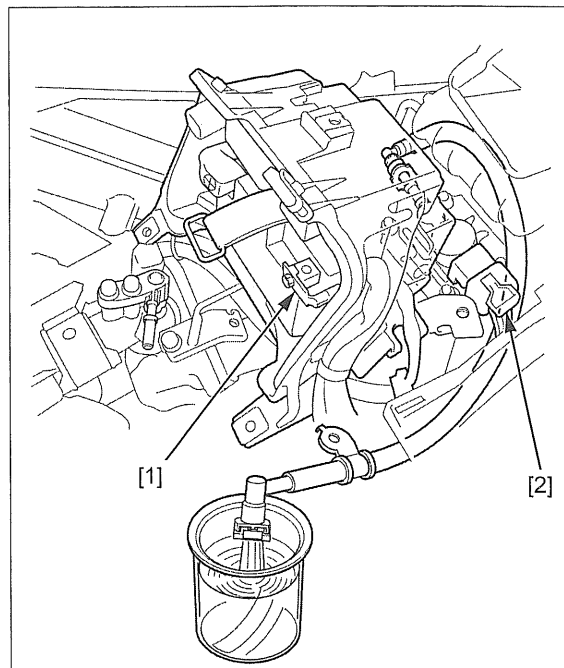

## FUEL SUPPLY TEST (AFTER '13 MODEL)

### 1. Fuel Pressure Test 1.

Perform the fuel pressure test (page 7-8).

**Standard: 263 – 316 kPa (2.7 – 3.2 kgf/cm<sup>2</sup>,  
38 – 46 psi)**

*Is the fuel pressure within specification?*

**YES** – GO TO STEP 3.

**NO** – GO TO STEP 2.

### 2. Fuel Pressure Test 2.

Check for any erratic swings or vibrations of the gauge needle.

*Are there any erratic swings or vibrations of the gauge needle?*

**YES** – Replace the fuel filter (page 7-11).

**NO** – Replace the fuel pump unit (page 7-10).

## FUEL SYSTEM

### 3. Fuel Flow Test

Adjust the fuel in the tank until the fuel gauge segment [1] is positioned the specified range.

**SPECIFIED RANGE: one segment**

Inspect the fuel flow (page 7-9).

**AMOUNT OF FUEL FLOW:**

**82 cm<sup>3</sup> (2.77 US oz, 2.89 Imp oz) minimum/  
10 seconds**

**Is the fuel flow above specification?**

**YES** – Check for other malfunctioning parts.

**NO** – Replace the fuel filter (page 7-11).

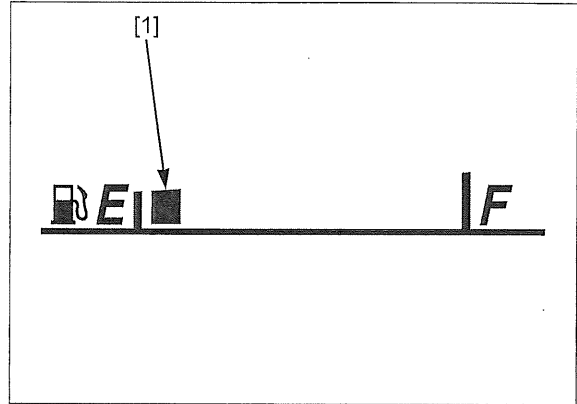

## FUEL PUMP UNIT

### SYSTEM INSPECTION

Before starting inspection, check that the MIL is operating normally.

Turn the ignition switch ON and engine stop switch "O", and confirm that the fuel pump operates for 2 seconds. If the fuel pump does not operate, inspect as follows:

Turn the ignition switch OFF.

Disconnect the fuel pump 5P connector (page 7-6).

Turn the ignition switch ON and measure the voltage at the fuel pump 5P connector [1] terminals of the wire harness side.

**CONNECTION: Black/white (+) – Brown/yellow (–)**

**STANDARD: Battery voltage**

There should be standard voltage for a few seconds.

If there is standard voltage, replace the fuel pump unit.

If there is no standard voltage, inspect the following:

- Open circuit in the Black/white or Brown/yellow wire
- ECM (page 4-50)

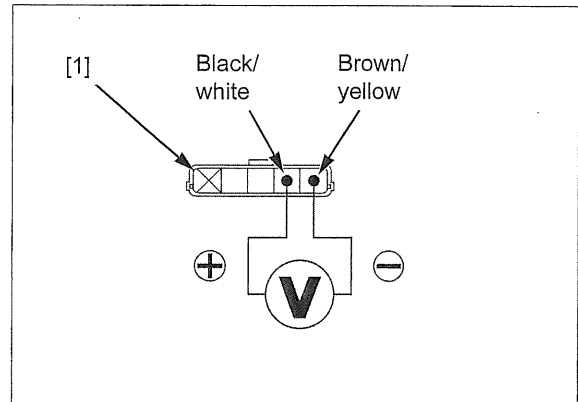

### REMOVAL

**NOTE:**

- This scooter uses resin for the part of materials in the fuel hose. Do not bend or twist the fuel hose.

Relieve the fuel pressure and disconnect the fuel pump side quick connect fitting (page 7-6).

Remove the following:

- Battery box (page 2-26)
- EVAP canister (EXCEPT After '13 model CM type) (page 7-28)

Clean around the fuel pump.

Loosen the nuts [1] in a crisscross pattern in several steps and remove it.

Remove the set plates [2].

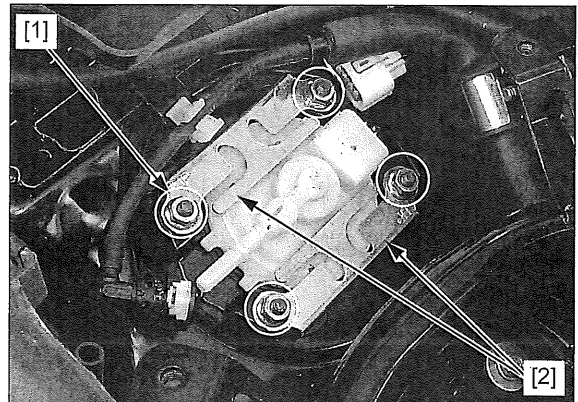



Pull up the fuel pump unit [1] until the edge of the fuel filter [2] comes out of the fuel tank hole.

Turn the fuel pump unit until the fuel filter comes out of the hole while folding the fuel filter to prevent damage.

**NOTE:**

Carefully remove the fuel pump unit from the fuel tank to prevent damage the fuel level sensor.

Remove the dust seal [3] and O-ring [4] from the fuel pump unit.

- Check the fuel filter for clogging or damage and replace it if necessary.

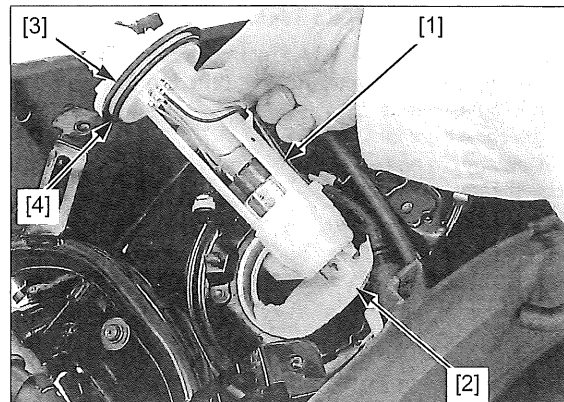

**FUEL FILTER REPLACEMENT**

Remove the fuel pump unit (page 7-10).

Release the hooks [1] of the fuel filter [2] from the stoppers [3] by slightly spreading the hooks, then turn the filter clockwise.

Pull up the filter and remove it from the fuel pump.

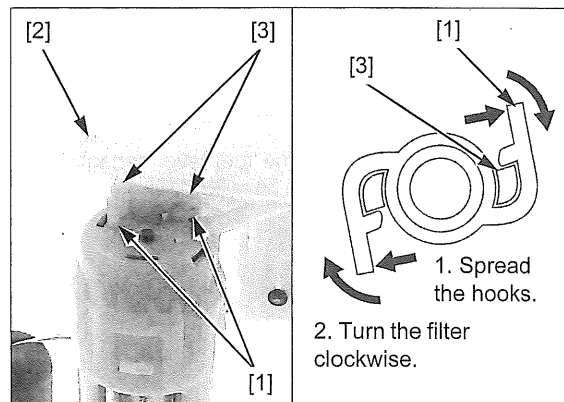

Remove the O-ring [1].

Apply a small amount of engine oil to a new O-ring and install it.

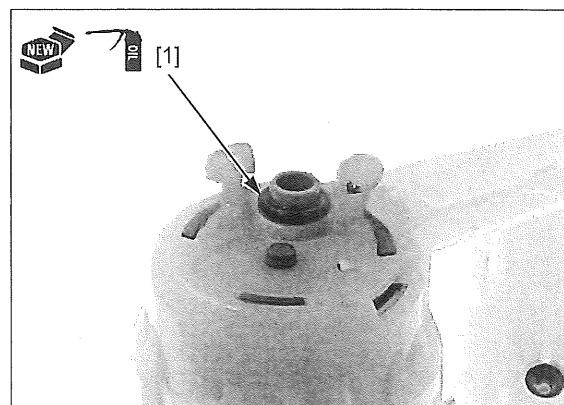

Install a new fuel filter [1] in the correct direction so that the triangle marks on the filter and fuel pump body will be aligned when it is hooked.

Turn the filter counterclockwise until the hooks [2] are completely secured by the stoppers [3], being careful not to damage them.

Install the fuel pump unit (page 7-12).

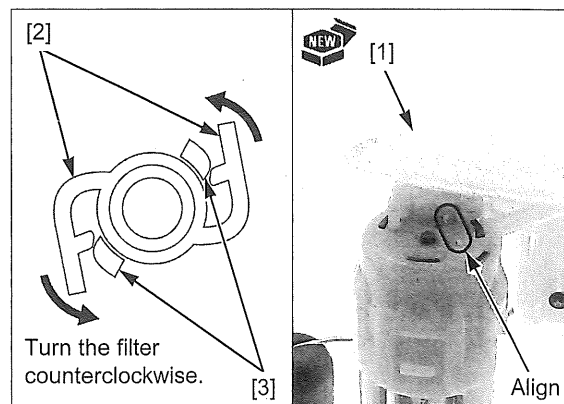

# FUEL SYSTEM

## INSTALLATION

Always replace the O-ring and dust seal with new ones. Be careful not to allow any dirt and debris between the fuel pump unit, O-ring and dust seal.

Apply 1 g maximum of engine oil to a new O-ring [1] and install it onto the fuel pump unit [2].

Install a new dust seal [3] in the correct direction as shown.

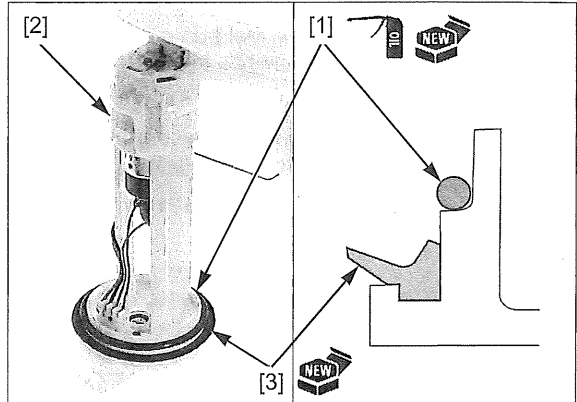

Apply a small amount of engine oil to the O-ring and dust seal seating area of the fuel tank.

Be careful not to damage the filter and float arm.

Install the fuel pump unit [1] to the fuel tank hole.

**NOTE:**

Insert the fuel level sensor into the tank while bending the fuel filter [2].

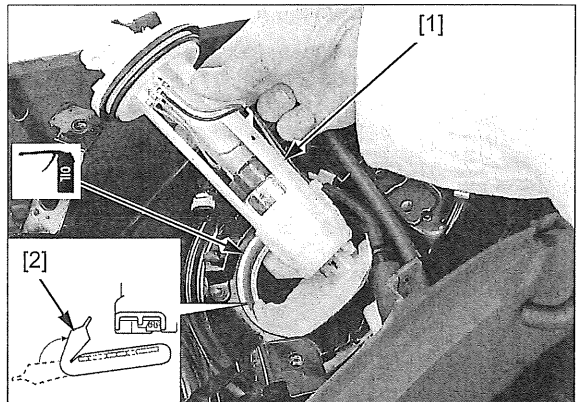

Push the fuel pump unit [1] into the fuel tank so that the pump tabs [2] are positioned between the ribs as shown.

**NOTE:**

Make sure the dust seal is installed properly.

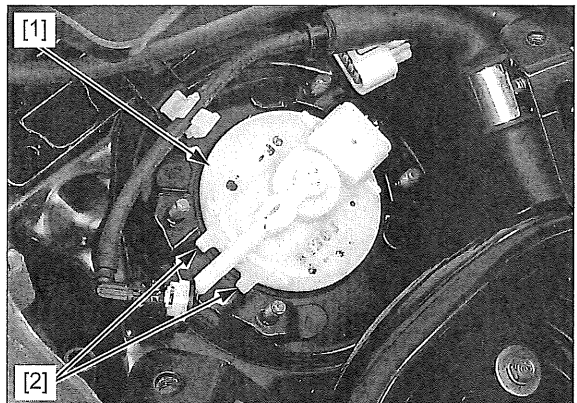

Install the set plates [1] with their "UP" marks [2] facing up while pushing down the fuel pump unit.

Install and tighten the fuel pump set plate nuts [3] to the specified torque in the specified sequence as shown.

**TORQUE: 12 N·m (1.2 kgf·m, 9 lbf·ft)**

Connect the fuel pump side quick connect fitting and normalize the fuel pressure (page 7-7).

Install the following:

- EVAP canister (EXCEPT After '13 model CM type) (page 7-28)
- Battery box (page 2-26)

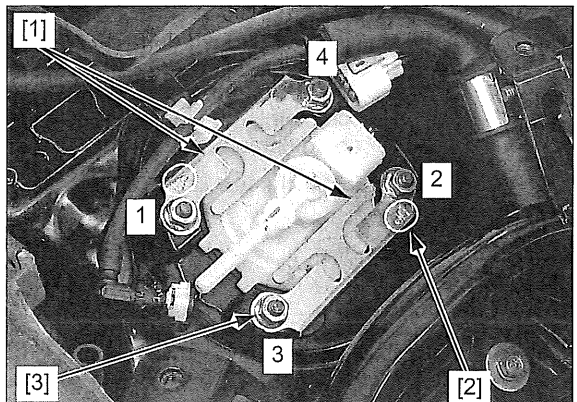

## FUEL TANK

### REMOVAL/INSTALLATION

Remove the following:

- Battery box (page 2-26)
- EVAP canister (EXCEPT After '13 model CM type) (page 7-28)
- Floor step (page 2-19)

Relieve the fuel pressure and disconnect the fuel pump side quick connect fitting (page 7-6).

Release the fuel hose [1] from the clamp [2] and wire band boss [3] from the fuel tank.

Disconnect the fuel tank breather hose [4].

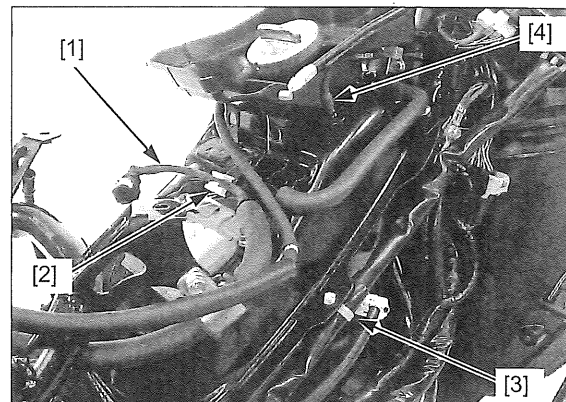

*EXCEPT After '13 model CM type:* Release the EVAP solenoid valve-to-intake pipe hose [1] from the hose guide [2].

Disconnect the fuel tray drain hose [3] from the fuel tray [4].

Remove the fuel tank cap [5] and fuel tray.

Install the fuel tank cap.

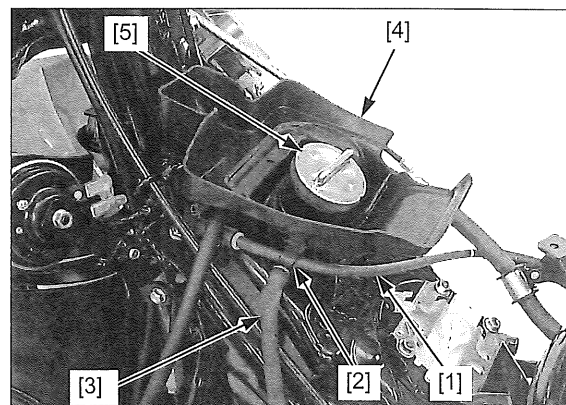

Remove the following:

- Two bolts [1]
- Bolt/washers [2]
- Collar [3]
- Fuel tank [4]

Installation is in the reverse order of removal.

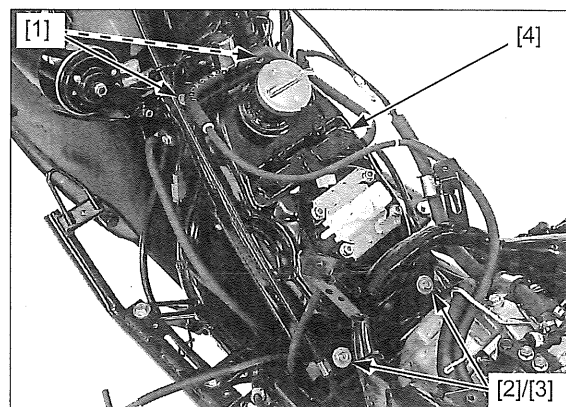

## AIR CLEANER HOUSING

### REMOVAL/INSTALLATION

Remove the luggage box (page 2-25).

Remove the socket bolt [1] from the rear inner fender.

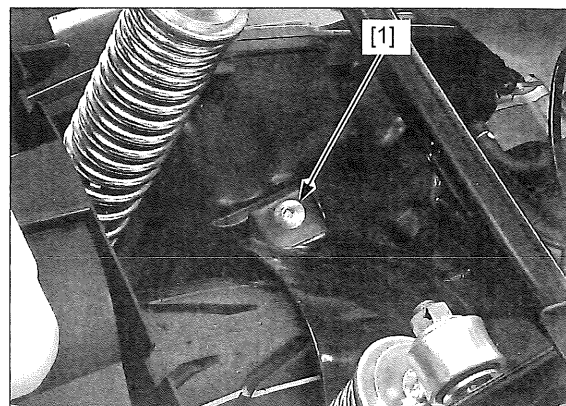

## FUEL SYSTEM

Pull out the final reduction case breather hose [1] from the air cleaner housing groove [2].

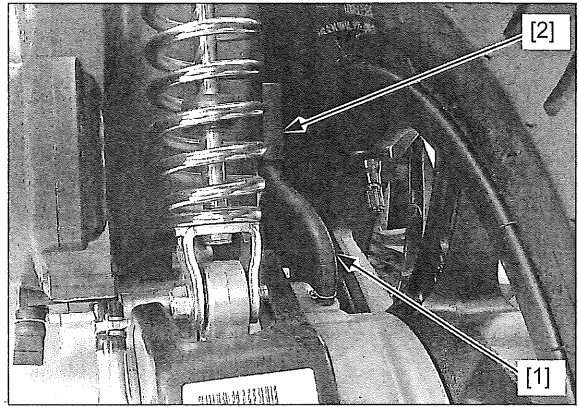

Remove the two air cleaner housing mounting bolts [1] from the left side.

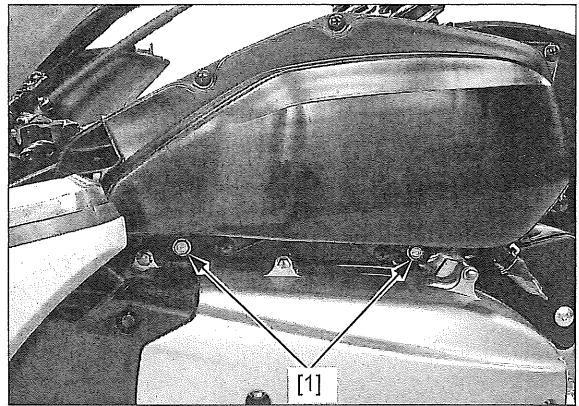

Disconnect the crankcase breather hose [1] from the air cleaner housing.

Loosen the air cleaner connecting hose band screw [2].

Disconnect the connecting hose [3] from the throttle body by holding the throttle body and pulling the air cleaner housing backward.

Remove the air cleaner housing.

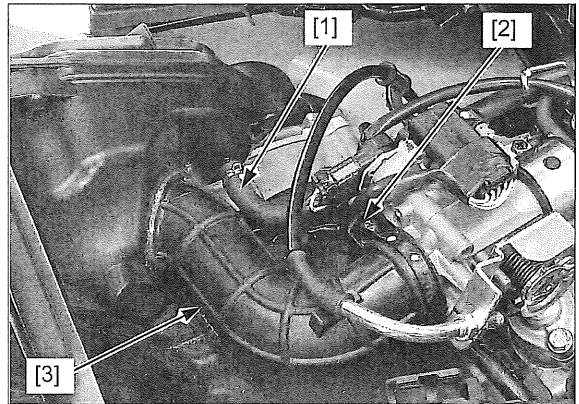

Installation is in the reverse order of removal

- Set the connecting hose band with its band screw [1] facing left side as shown.
- Tighten the air cleaner connecting hose band screw until the band seat on the collar [2].

### TORQUE:

**Air cleaner housing mounting bolt:**

11 N·m (1.1 kgf·m, 8 lbf·ft)

**Rear inner fender socket bolt:**

3.5 N·m (0.36 kgf·m, 2.6 lbf·ft)

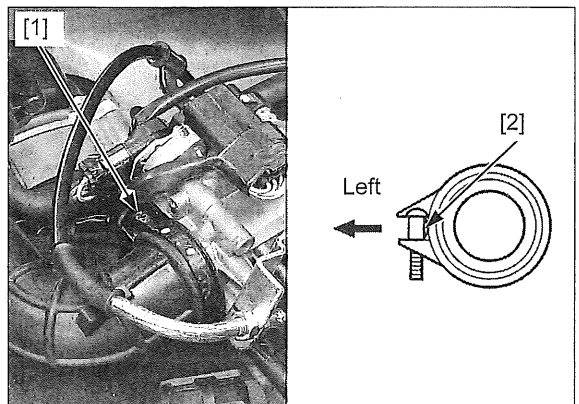

## THROTTLE BODY

### REMOVAL ('13 MODEL)

- If the sensor unit has been removed, perform the TP sensor reset procedure (page 7-21).

Remove the luggage box (page 2-25).

Loosen the throttle cable lock nut [1].

Disconnect the throttle cable [2] from the cable bracket [3] and throttle drum [4].

Disconnect the sensor unit 5P (Black) connector [5] and IACV 4P (Black) connector [6].

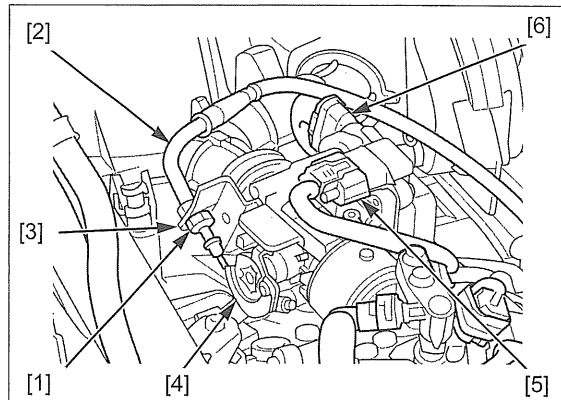

Loosen the connecting hose band screw [1] and insulator band bolts [2].

Remove the throttle body [3].

- Seal the intake pipe with a shop towel or cover it with a piece of tape to prevent any foreign material from dropping into the engine.

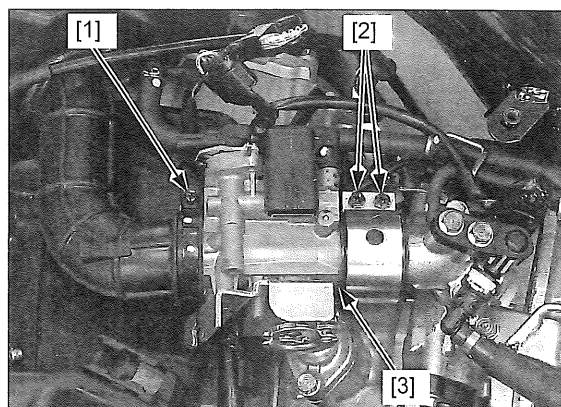

### REMOVAL (AFTER '13 MODEL)

Remove the luggage box (page 2-25).

Loosen the throttle cable nuts [1].

Disconnect the throttle cables [2] from the cable bracket [3] and throttle drum [4].

Disconnect the sensor unit 5P (Black) connector [5] and IACV 4P (Black) connector [6].

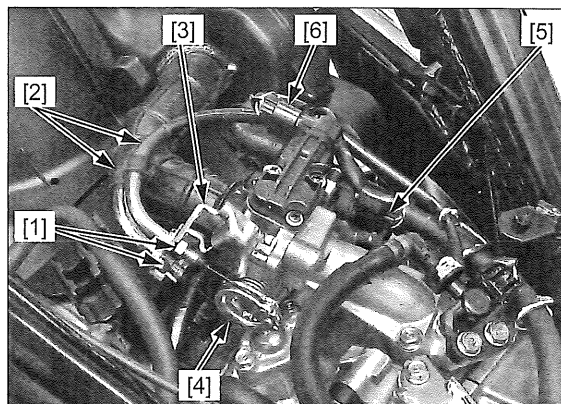

Loosen the connecting hose band screw [1] and remove the intake pipe bolts [2].

Remove the throttle body [3].

- Seal the intake pipe with a shop towel or cover it with a piece of tape to prevent any foreign material from dropping into the engine.

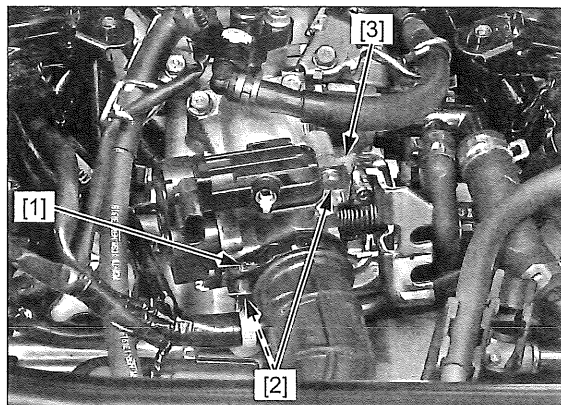

## DISASSEMBLY

- The throttle body is factory pre-set. Do not disassemble in a way other than shown in this manual.
- Do not snap the throttle valve from full open to full close after the throttle cable has been removed. It may cause incorrect idle operation.
- Do not damage the throttle body. It may cause incorrect throttle valve operation.
- Do not loosen or tighten the white painted nut [1] of the throttle drum. Loosening or tightening it can cause throttle body malfunction.

'13 model:

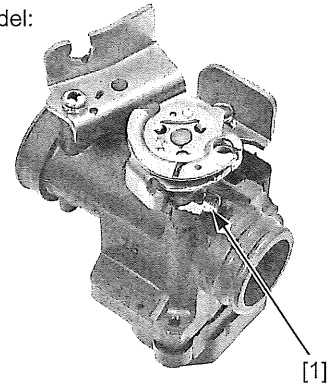

After '13 model:

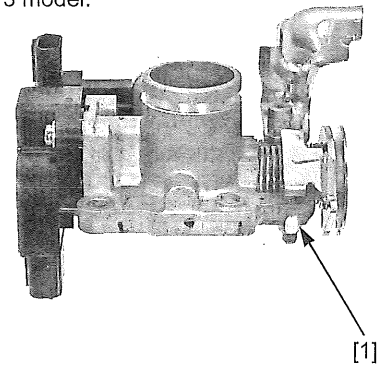

- '13 model:
- Always clean around the throttle body before the sensor unit removal to prevent dirt and debris from entering the air passage.

Remove the torx screws [1], sensor unit [2] and O-ring [3].

Remove the IACV (page 7-22).

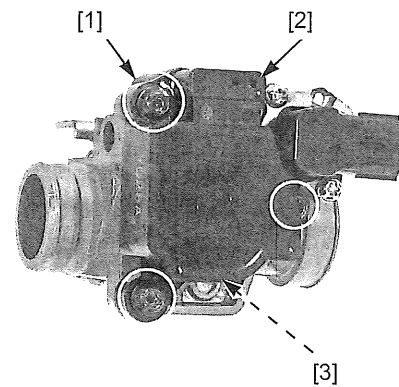

- After '13 model:
- Always clean around the throttle body before the sensor unit removal to prevent dirt and debris from entering the air passage.

Remove the screws [1], sensor unit [2] and O-ring [3].

Remove the IACV (page 7-23).

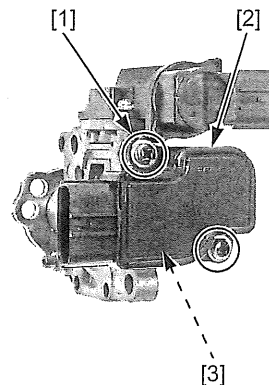



**CLEANING**

Blow open through each air passage in the throttle body [1] with compressed air.

- Do not use high pressure air or bring the nozzle too close to the throttle body.

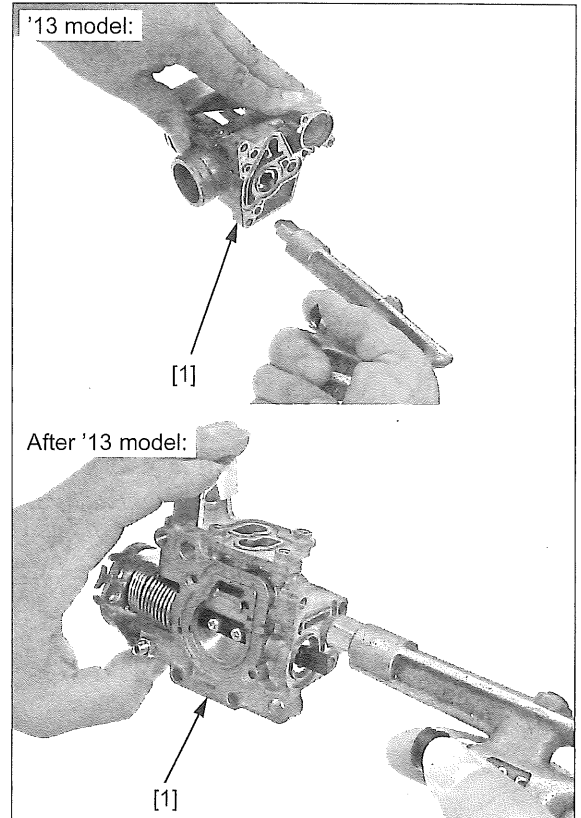

**ASSEMBLY ('13 MODEL)**

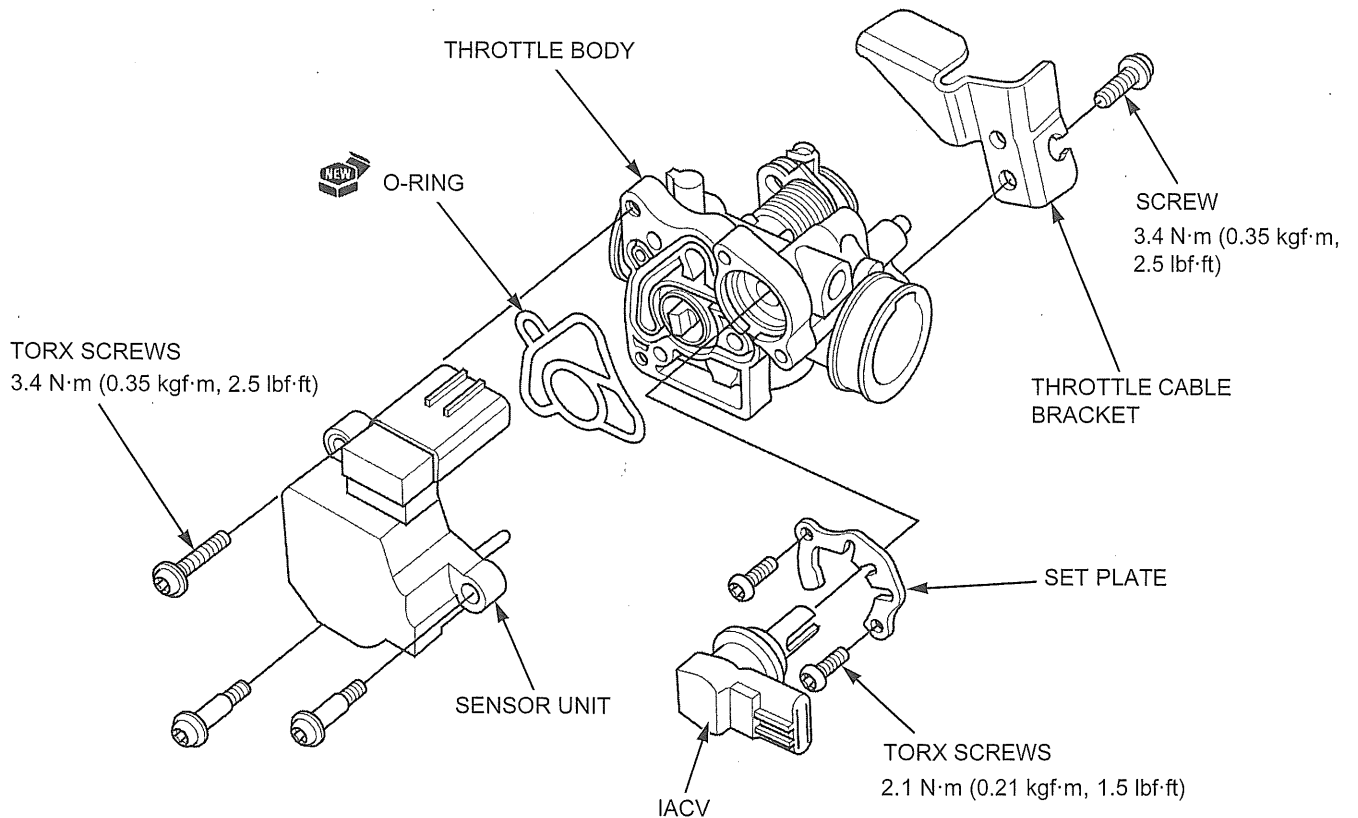

# FUEL SYSTEM

Install the IACV (page 7-22).

*If the O-ring is not installed properly, the idle air will leak and engine idle speed will be unstable.*

Install a new O-ring [1] to the throttle body properly.

Install the sensor unit [2] to the throttle body by aligning the clip of the TP sensor and boss of the throttle valve.

- Light pressure is sufficient to assemble the sensor unit and throttle body in the correct position. If you cannot assemble them easily, the clip may be misaligned. Do not attempt to force them together and make sure that the clip is aligned.

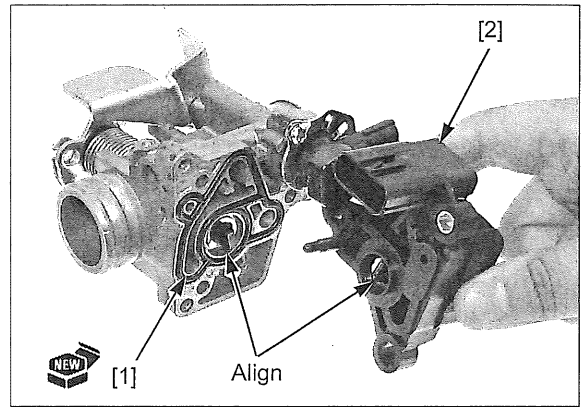

Install and tighten the torx screws [1] to the specified torque.

**TORQUE: 3.4 N·m (0.35 kgf·m, 2.5 lbf·ft)**

- After installing the throttle body, perform the TP sensor reset procedure (page 7-21).

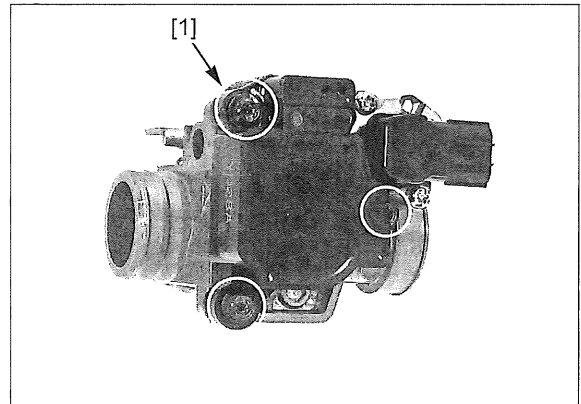

## ASSEMBLY (AFTER '13 MODEL)

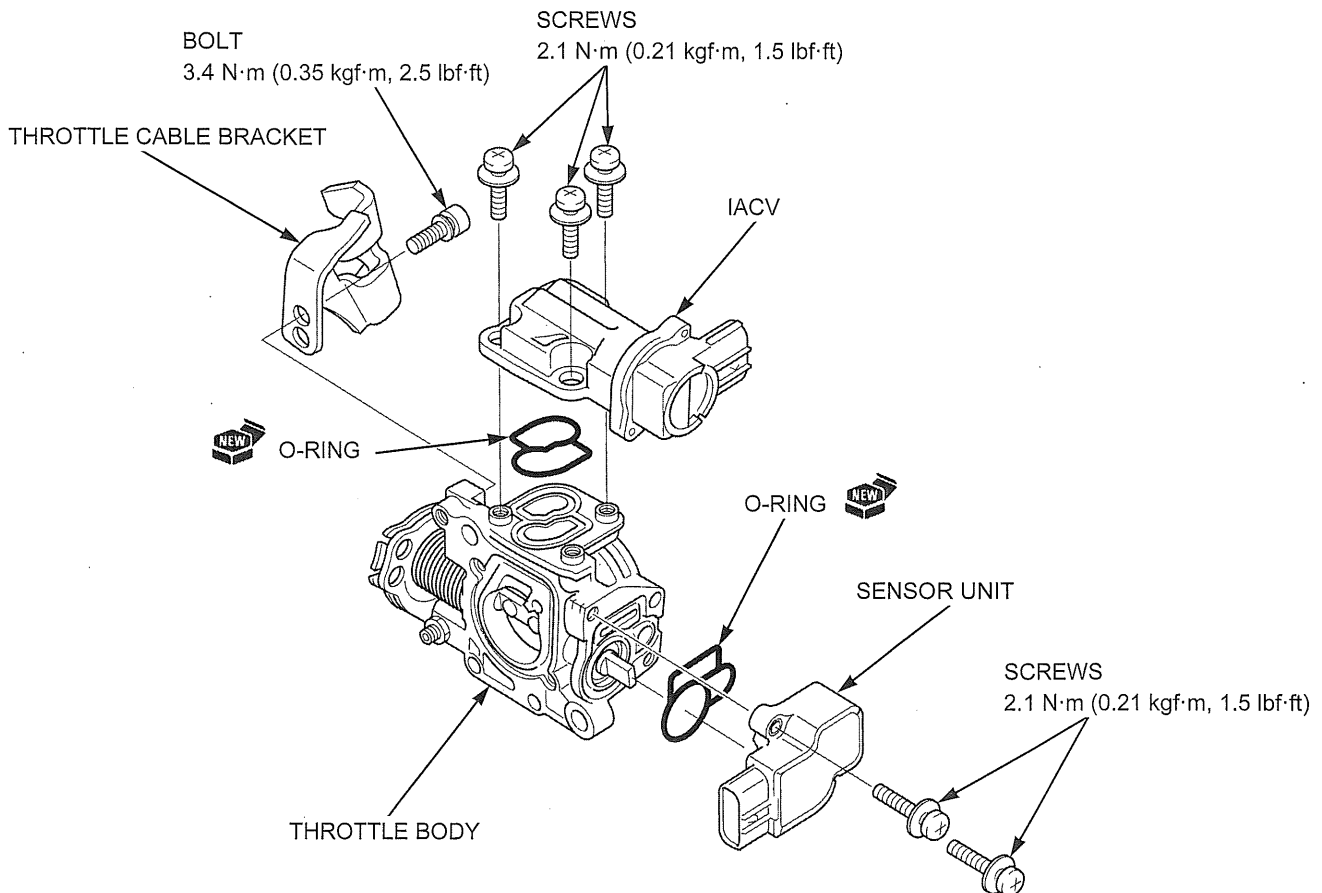



*If the O-ring is not installed properly, the idle air will leak and engine idle speed will be unstable.*

Install a new O-ring [1] to the throttle body properly.

Install the sensor unit [2] to the throttle body by aligning the clip of the TP sensor and boss of the throttle valve.

- Light pressure is sufficient to assemble the sensor unit and throttle body in the correct position. If you cannot assemble them easily, the clip may be misaligned. Do not attempt to force them together and make sure that the clip is aligned.
- Do not hold the throttle drum when installing the sensor unit.

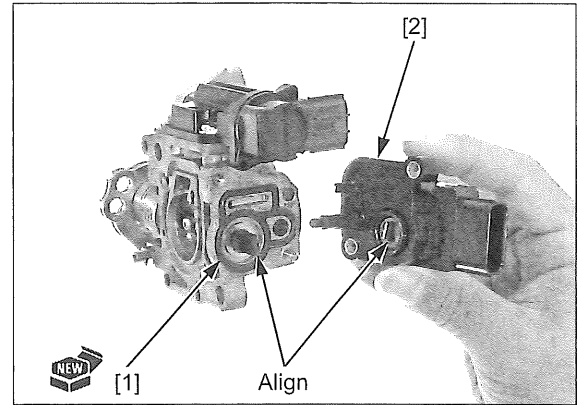

Install and tighten the screws [1] to the specified torque.

**TORQUE: 2.1 N·m (0.21 kgf·m, 1.5 lbf·ft)**

- After installing the throttle body, perform the TP sensor reset procedure (page 7-21).

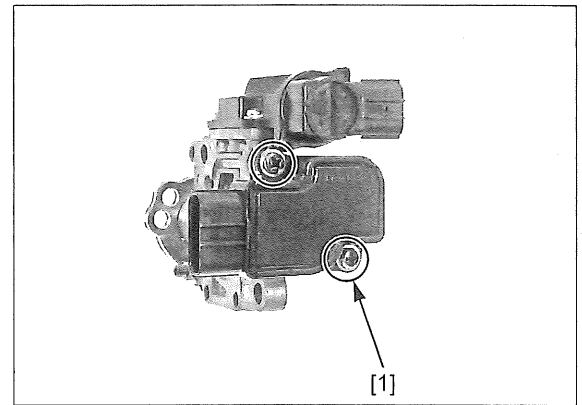

### INSTALLATION ('13 MODEL)

Install the throttle body [1] between the connecting hose [2] and insulator band [3].

Align the throttle body tab with the insulator band groove.

Tighten the insulator band bolts [4] to the specified torque.

**TORQUE: 5 N·m (0.51 kgf·m, 3.7 lbf·ft)**

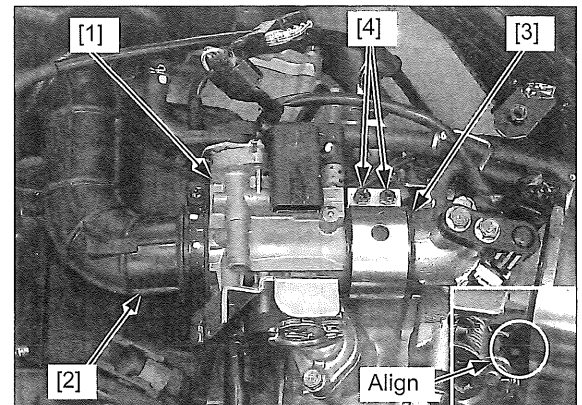

Position the connecting hose band with its band screw [1] facing left side as shown.

Tighten the connecting hose band screw until the band seats on the collar [2].

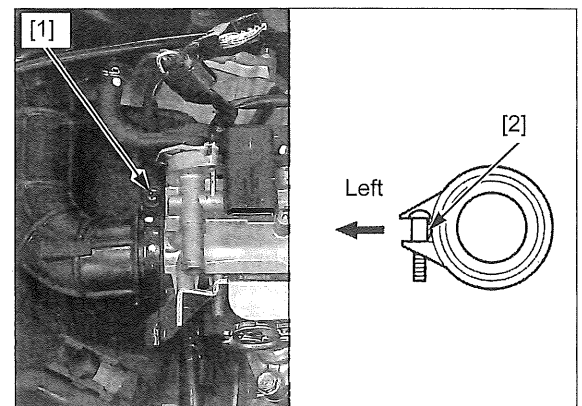

## FUEL SYSTEM

Connect the sensor unit 5P (Black) connector [1] and IACV 4P (Black) connector [2].

Connect the throttle cable [3] to the throttle drum [4] and cable bracket [5], then adjust the throttle grip freeplay (page 3-6).

- Set the throttle cable against the connecting hose.

Install the luggage box (page 2-25).

If the sensor unit has been removed, perform the TP sensor reset procedure (page 7-21).

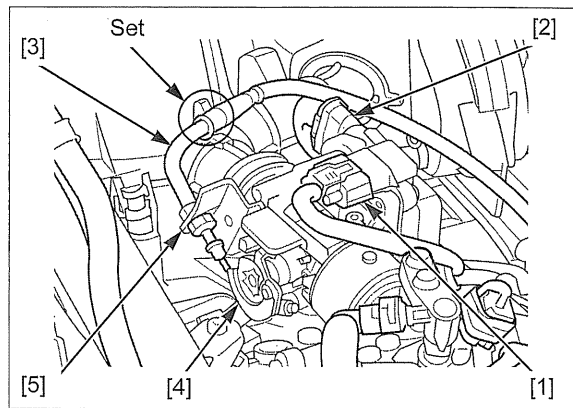

### INSTALLATION (AFTER '13 MODEL)

Install the throttle body [1] between the connecting hose [2] and intake pipe [3].

Tighten the intake pipe bolts [4].

Position the connecting hose band with its connecting hose band screw [5] facing the left side as shown.

Tighten the connecting hose band screw until the band seats the collar [6].

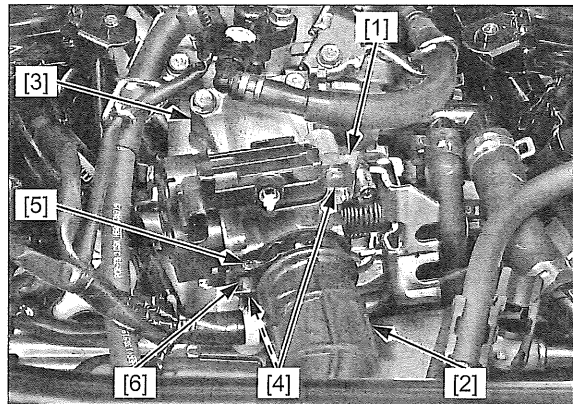

Connect the sensor unit 5P (Black) connector [1] and IACV 4P (Black) connector [2].

Connect the lower throttle cable [3] first, then connect the upper throttle cable [4] to the throttle drum [5] and cable bracket [6].

Tighten the throttle cable nuts [7] to the specified torque.

**TORQUE: 8.5 N·m (0.87 kgf·m, 6.3 lbf·ft)**

Adjust the throttle grip freeplay (page 3-6).

Install the luggage box (page 2-25).

If the sensor unit has been removed, perform the TP sensor reset procedure (page 7-21).

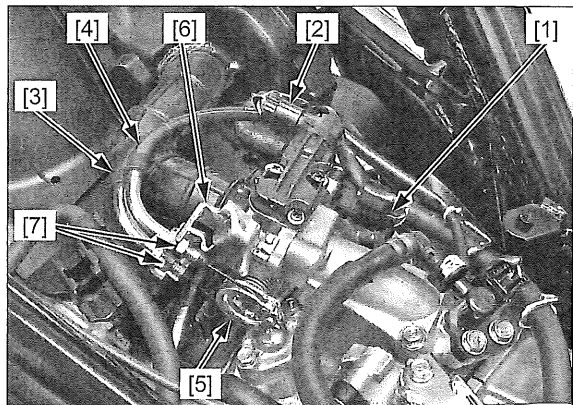

### TP SENSOR RESET PROCEDURE

- Make sure that no DTC is stored in the ECM. If a DTC is stored, follow the TP sensor reset procedure below.

Remove the following:

- Battery maintenance lid (page 20-7)
- Right side cover (page 2-8)

1. Turn the ignition switch OFF.
2. Remove the dummy connector [1] from the DLC [2].
3. Connect the special tool to the DLC.

**TOOL:**

[3] SCS connector                      070PZ-ZY30100

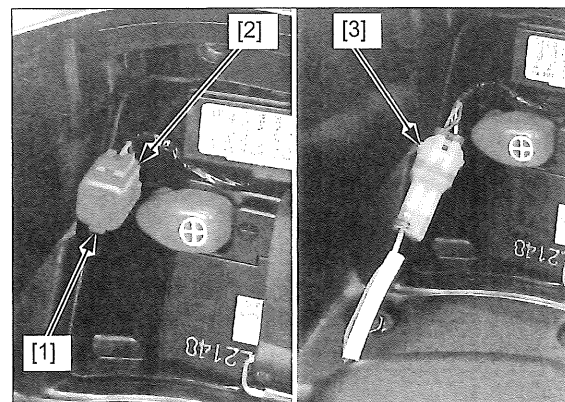

4. Disconnect the ECT sensor 2P (Black) connector [1].

Short the ECT sensor terminals with jumper wire [2].

**CONNECTION: Pink/white – Green/orange**

5. Turn the ignition switch ON and engine stop switch "O", then disconnect the jumper wire from the ECT sensor 2P (Black) connector within 10 seconds while the MIL is blinking (reset receiving pattern).
6. Check if the MIL blinks.

After disconnection of the jumper wire, the MIL should start blinking. (successful pattern)

If the jumper wire is disconnected for more than 10 seconds, the MIL will stay ON (unsuccessful pattern). Try again from the step 4.

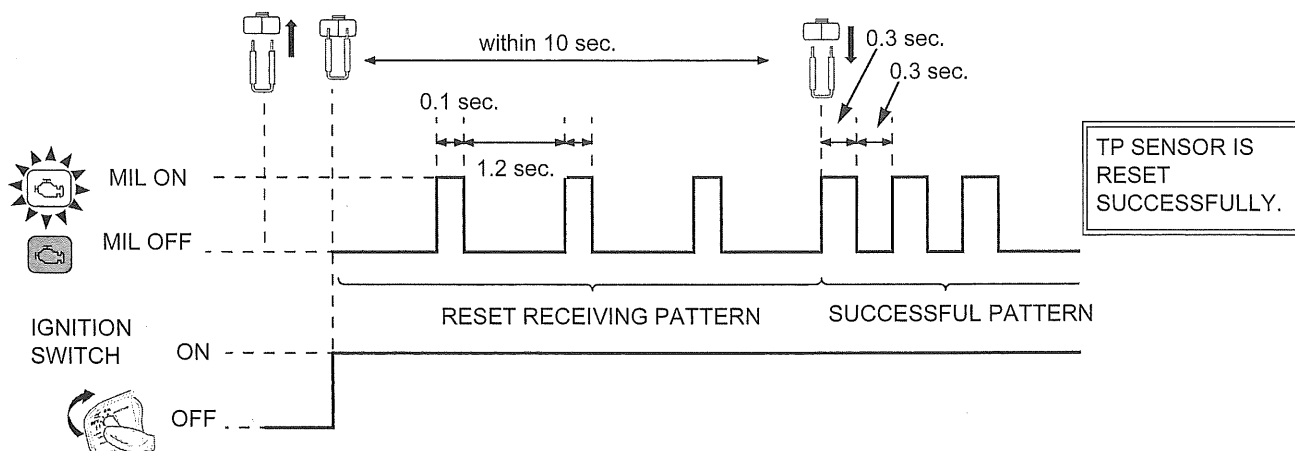
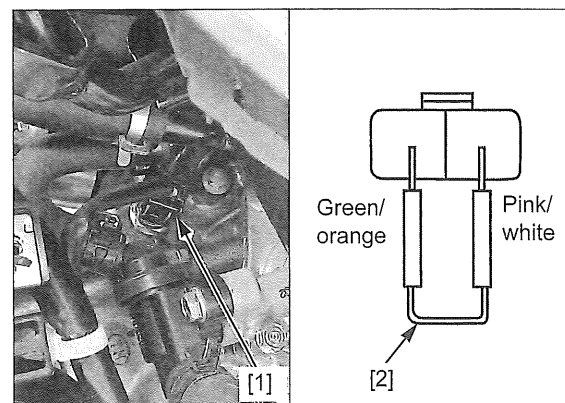

Install the removed parts in the reverse order of removal.

Check the engine idle speed (page 3-13).

## IACV

### REMOVAL ('13 MODEL)

Remove the left side cover (page 2-8).

Disconnect the IACV 4P (Black) connector [1].

Remove the torx screws [2], set plate [3] and IACV [4].

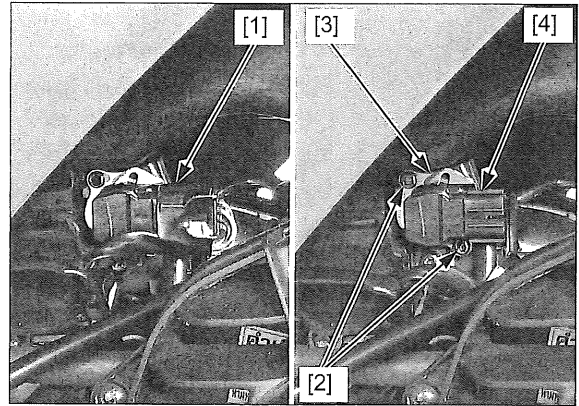

### INSTALLATION ('13 MODEL)

Turn the slide valve [1] clockwise until lightly seated on IACV [2].

Install the set plate [3] by aligning the tab of the IACV with the slot of set plate as shown.

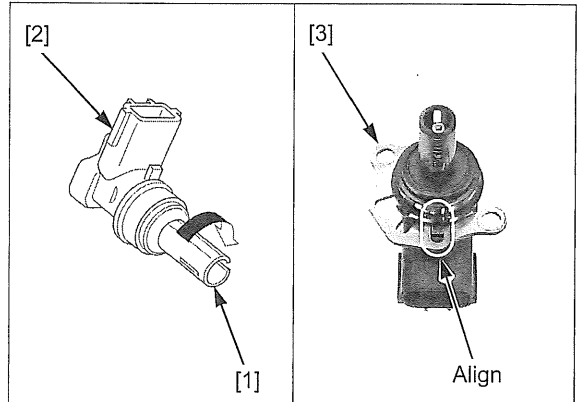

Install the IACV [1] by aligning the pin with the slide valve slot.

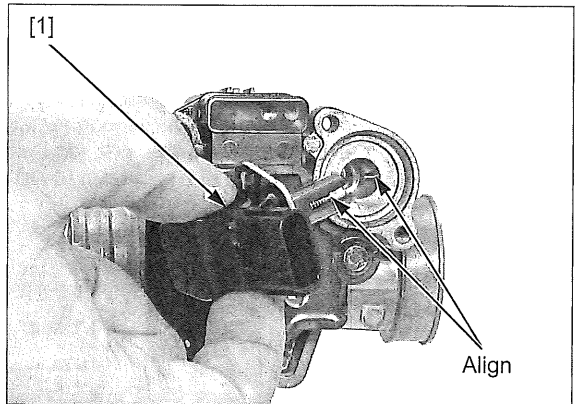

Install and tighten the torx screws [1] to the specified torque.

**TORQUE: 2.1 N·m (0.21 kgf·m, 1.5 lbf·ft)**

Connect the IACV 4P (Black) connector [2].

Install the left side cover (page 2-8).

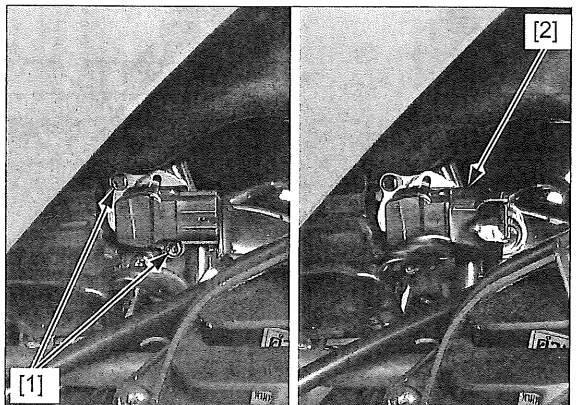

## REMOVAL/INSTALLATION (AFTER '13 MODEL)

Remove the luggage box (page 2-25).  
 Disconnect the IACV 4P (Black) connector [1].  
 Remove the screws [2], IACV [3] and O-ring [4].  
 Installation is in the reverse order of removal.

### TORQUE:

**IACV screw: 2.1 N·m (0.21 kgf·m, 1.5 lbf·ft)**

### NOTE:

- Replace the O-ring with a new one.
- Replace the IACV as an assembly when it is faulty.

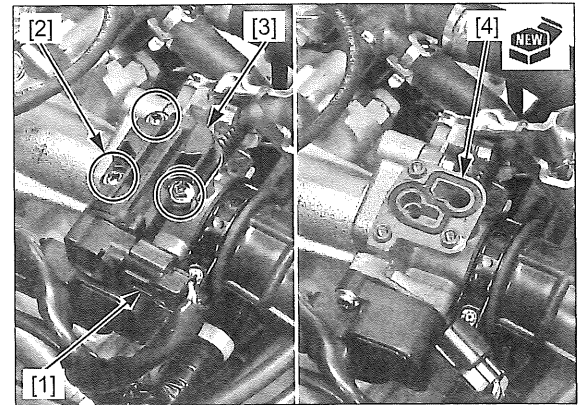

## INSPECTION ('13 MODEL)

The IACV is installed on the throttle body and is operated by the step motor. When the ignition switch is turned ON and engine stop switch "O", the IACV operates for a few seconds.

Check the step motor operating sound with the ignition switch turned ON.

Remove the IACV (page 7-22).

Check the IACV slide valve [1] and IACV air passage in the throttle body for carbon deposits.  
 Clean the IACV slide valve and IACV air passage if necessary.

Temporarily connect the IACV 4P (Black) connector [2].  
 Turn the ignition switch ON.  
 The slide valve should move back and forth.

Turn the ignition switch OFF.  
 Disconnect the IACV 4P (Black) connector and install the IACV (page 7-22).

Recheck the engine idle speed (page 3-13).

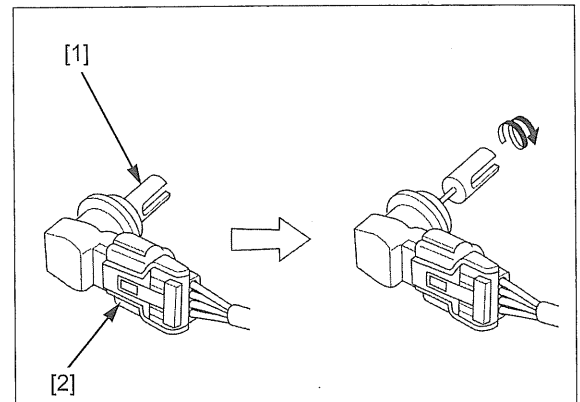

## INSPECTION (AFTER '13 MODEL)

Remove the IACV (page 7-22).

Check the IACV [1] for wear or damage.

The IACV operation can be checked visually as follows:

1. Connect the IACV 4P (Black) connector.
2. Turn ignition switch ON, check the slide piece [2] operation.

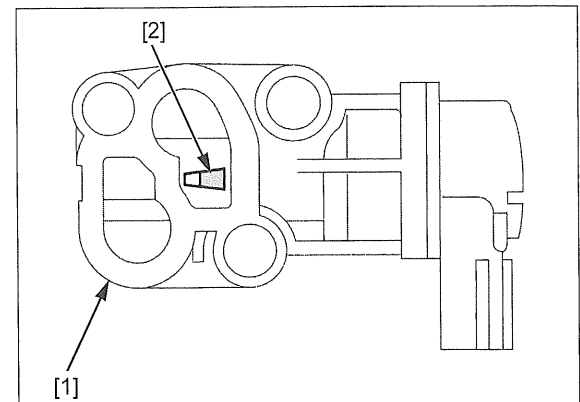

## FUEL INJECTOR

### REMOVAL

- Always clean around the fuel injector before removal to prevent dirt and debris from entering the fuel injector passage.

Relieve the fuel pressure and disconnect the fuel injector side quick connect fitting (page 7-6).

Disconnect the fuel injector 2P (Black) connector [1].

Remove the bolts [2], and fuel injector joint/injector [3] from the intake pipe.

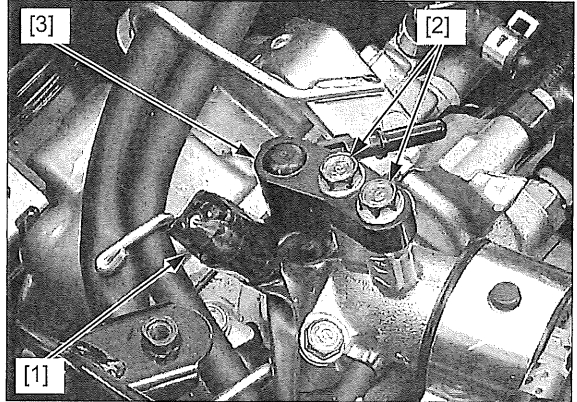

Remove the fuel injector [1] from the fuel injector joint [2].

Remove the O-ring [3] and seal ring [4] from the fuel injector.

Check the removed parts for wear or damage and replace them if necessary.

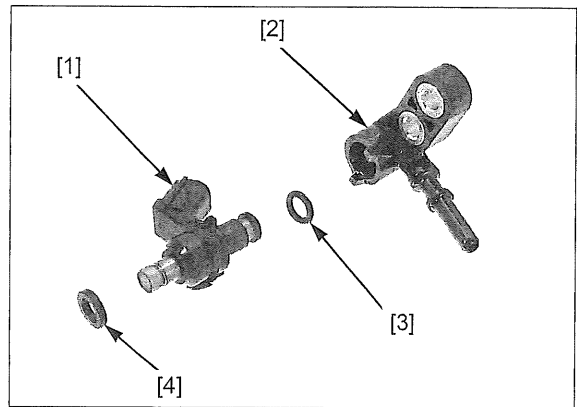

### INSTALLATION

Coat new O-ring [1] and seal ring [2] with engine oil. Install a new O-ring and seal ring to the fuel injector [3], being careful not to damage them.

Install the fuel injector joint [4] to the fuel injector by aligning the both tabs.

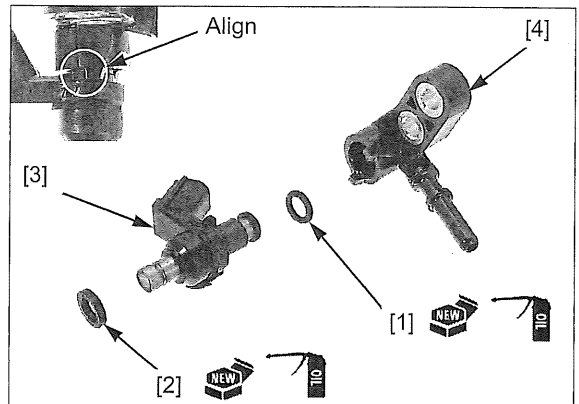

Install the fuel injector joint/injector [1] into the intake pipe.  
Install and tighten the fuel injector joint mounting bolts [2].

Connect the fuel injector 2P (Black) connector [3].

Connect the fuel injector side quick connect fitting and normalize the fuel pressure (page 7-7).

Install the removed parts in the reverse order of removal.

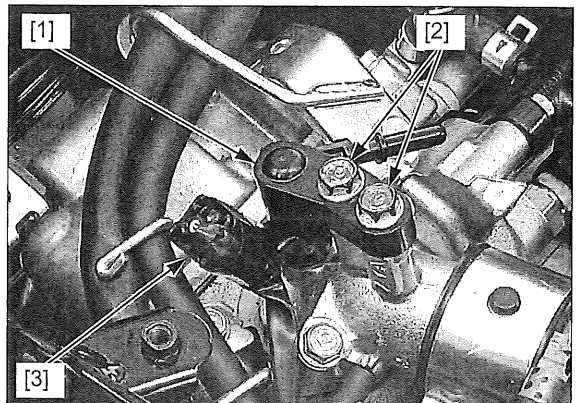

## INTAKE PIPE

### REMOVAL ('13 MODEL)

Remove the fuel injector (page 7-24).

Disconnect the EVAP canister-to-intake pipe hose [1] from the intake pipe joint.

Loosen the insulator band bolts [2].

Remove the intake pipe mounting bolts [3].

Remove the intake pipe/insulator band [4] from the throttle body.

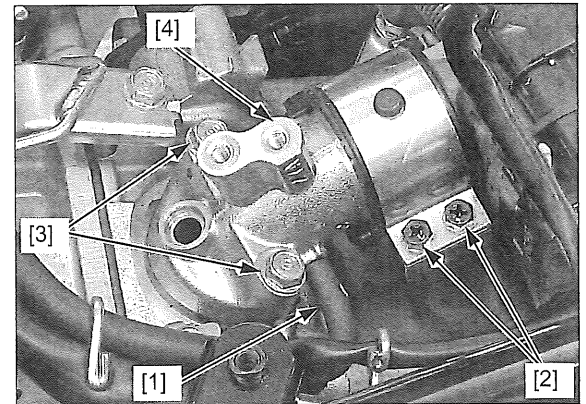

Remove the insulator [1] from the intake port.

Remove the O-rings [2] from the insulator.

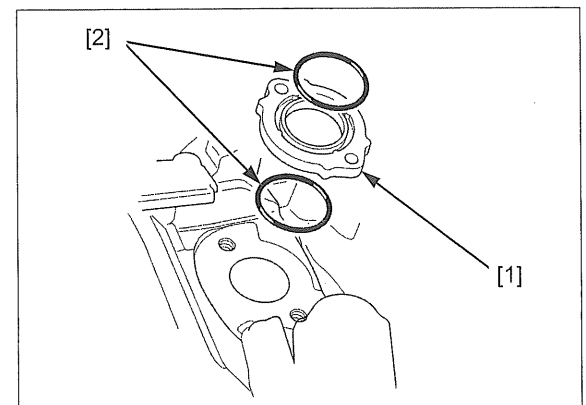

Remove the insulator band [1] from the intake pipe [2].

Seal the cylinder head intake port with a shop towel or cover it with a piece of tape to prevent any foreign material from dropping into the engine.

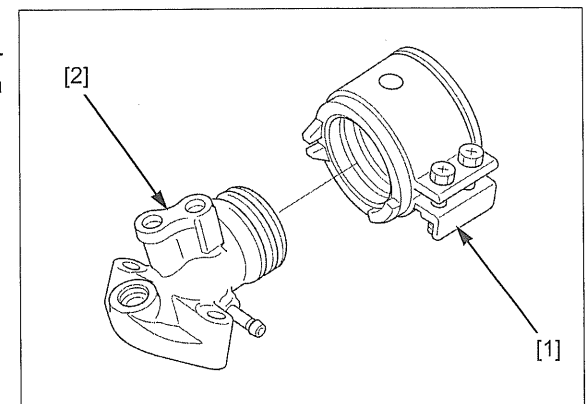

### INSTALLATION ('13 MODEL)

Install the insulator band [1] to the intake pipe [2] by aligning the tab and groove.

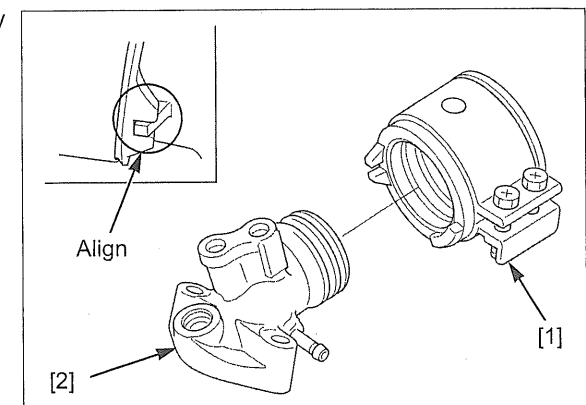



## FUEL SYSTEM

Install the new O-rings [1] to the groove on the insulator [2].

Set the insulator to the intake port.

Install the intake pipe/insulator band [3] to the throttle body by aligning the tab and groove.

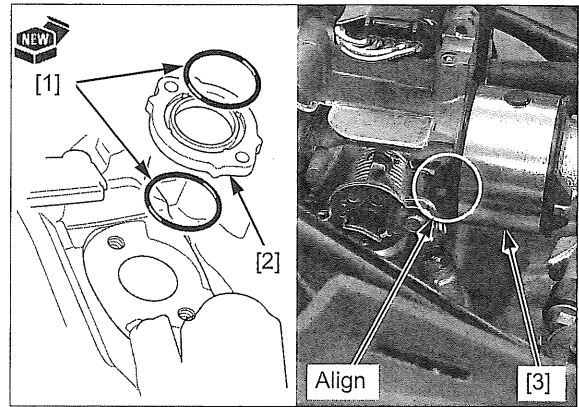

Install and tighten the intake pipe mounting bolts [1].

Tighten the insulator band bolts [2] to the specified torque.

**TORQUE: 5 N·m (0.51 kgf·m, 3.7 lbf·ft)**

Connect the EVAP canister-to-intake pipe hose [3] to the intake pipe joint.

Install the fuel injector (page 7-24).

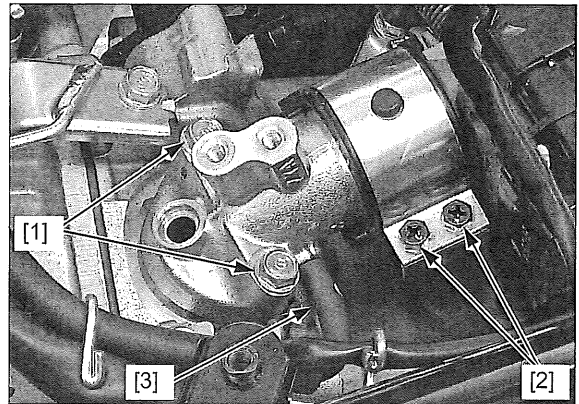

### REMOVAL/INSTALLATION (AFTER '13 MODEL)

Remove the luggage box (page 2-25).

Disconnect the following:

- Quick connect fitting [1] (page 7-6)
- Injector 2P (Black) connector [2]

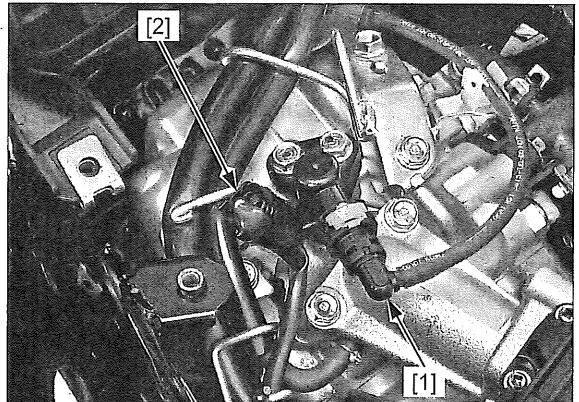

Remove the intake pipe bolts [1] and bolts [2].

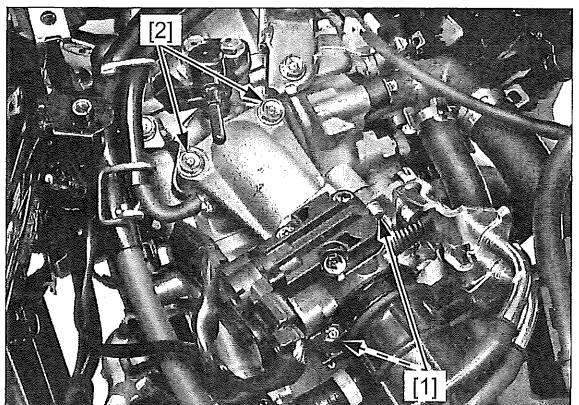



Remove the insulator [1] and O-rings [2].

**NOTE:**

- Seal the cylinder head intake port with a shop towel or cover it with a piece of tape to prevent any foreign material from dropping into the engine.

Installation is in the reverse order of removal.

**NOTE:**

- Replace the O-rings with new ones.

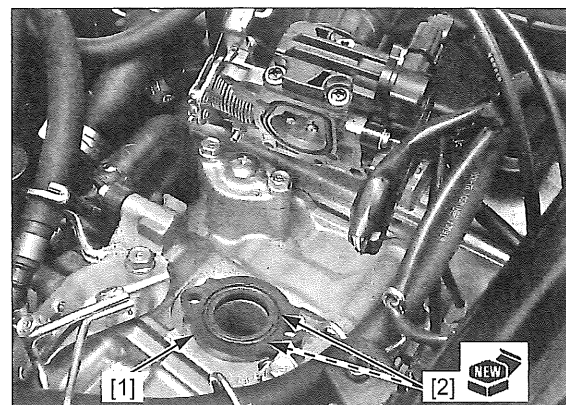

## EVAP PURGE CONTROL SOLENOID VALVE (EXCEPT AFTER '13 MODEL CM TYPE)

### REMOVAL/INSTALLATION

Remove the center cover (page 2-10).

Disconnect the following:

- EVAP purge control solenoid valve 2P (Black) connector [1]
- EVAP purge control solenoid valve-to-intake pipe hose [2]
- EVAP canister-to-EVAP purge control solenoid valve hose [3]

Remove the two screws [4] and EVAP purge control solenoid valve [5].

Installation is in the reverse order of removal.

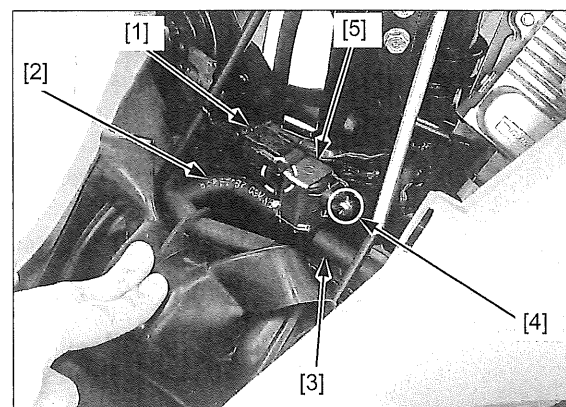

### INSPECTION

Remove the EVAP purge control solenoid valve (page 7-27).

Check that air flows (A) to (B) only when a 12 V battery is connected to the EVAP purge control solenoid valve terminals.

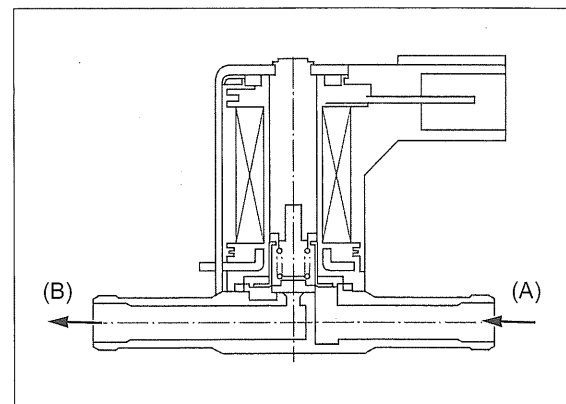

## FUEL SYSTEM

Check the resistance between the solenoid valve side of the EVAP purge control solenoid valve 2P (Black) connector [1] terminals.

**STANDARD: 30 – 34  $\Omega$  (20 °C/68 °F)**

If the resistance is out of specification, replace the EVAP purge control solenoid valve.

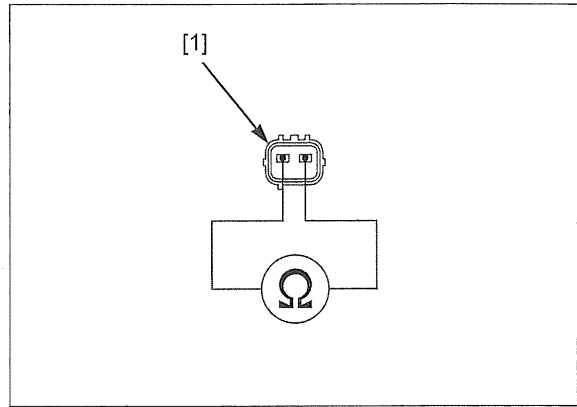

## EVAP CANISTER (EXCEPT AFTER '13 MODEL CM TYPE)

### REMOVAL/INSTALLATION

Remove the front cover (page 2-15).

Disconnect the following from the EVAP canister [1]:

- EVAP canister drain hose [2]
- EVAP canister-to-fuel tank hose [3]
- Canister-to-EVAP purge control solenoid valve hose [4]

Remove the EVAP canister by releasing the groove from the frame.

Installation is in the reverse order of removal.

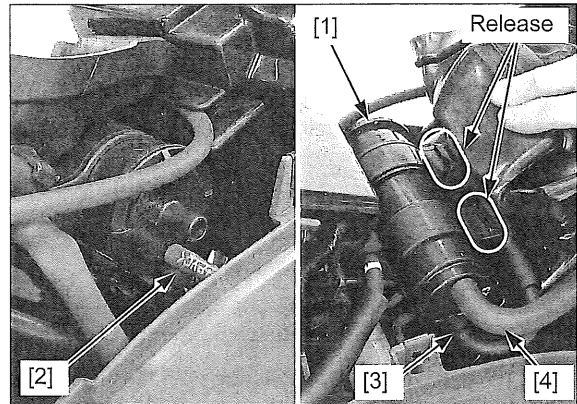

# 8. LUBRICATION SYSTEM

---

LUBRICATION SYSTEM DIAGRAM ..... 8-2

SERVICE INFORMATION ..... 8-3

TROUBLESHOOTING ..... 8-4

OIL PUMP ..... 8-5



LUBRICATION SYSTEM DIAGRAM

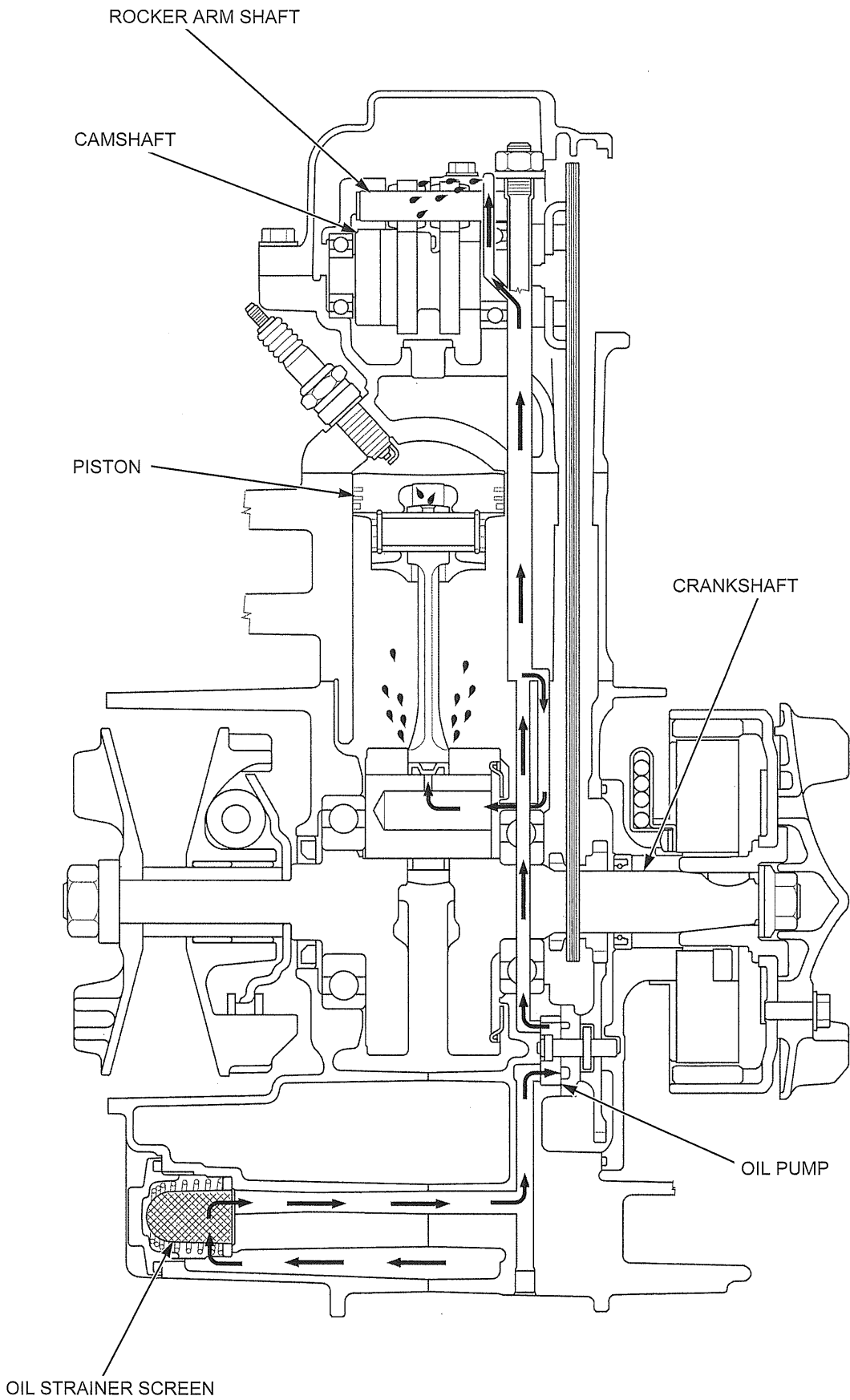

# SERVICE INFORMATION

## GENERAL

### ⚠ CAUTION

Used engine oil may cause skin cancer if repeatedly left in contact with the skin for prolonged periods. Although this is unlikely unless you handle used oil on a daily basis, it is still advisable to thoroughly wash your hands with soap and water as soon as possible after handling used oil.

- The oil pump can be serviced with the engine installed in the frame.
- The service procedures in this section must be performed with the engine oil drained.
- When removing and installing the oil pump, use care not to allow dust or dirt to enter the engine.
- If any portion of the oil pump is worn beyond the specified service limits, replace the oil pump as an assembly.
- After the oil pump has been installed, check that there are no oil leaks.

## SPECIFICATIONS

ITEM		STANDARD	SERVICE LIMIT
Engine oil capacity	After draining	0.8 liter (0.8 US qt, 0.7 Imp qt)	—
	After disassembly	0.9 liter (1.0 US qt, 0.8 Imp qt)	—
	After oil strainer removal	0.9 liter (1.0 US qt, 0.8 Imp qt)	—
Recommended engine oil		Pro Honda HP4M 4-stroke oil (U.S.A. and Canada) or equivalent motor oil API service classification: SJ or higher JASO T 903 standard: MB Viscosity: SAE 10W-30	—
Oil pump rotor	Oil pump body I.D.	23.150 – 23.180 (0.9114 – 0.9126)	—
	Outer rotor O.D.	22.970 – 23.000 (0.9043 – 0.9055)	—
	Body-to-outer rotor clearance	0.15 – 0.21 (0.0059 – 0.0083)	0.35 (0.014)
	Oil pump body depth	7.020 – 7.090 (0.2764 – 0.2791)	—
	Outer rotor height	6.960 – 6.980 (0.2740 – 0.2748)	—
	Side clearance	0.040 – 0.130 (0.0016 – 0.0051)	0.15 (0.006)

Unit: mm (in)

## TORQUE VALUE

ITEM	Q'TY	THREAD DIA. (mm)	TORQUE N·m (kgf·m, lbf·ft)	REMARKS
Oil pump mounting bolt	2	6	10 (1.0, 7)	

## TOOLS

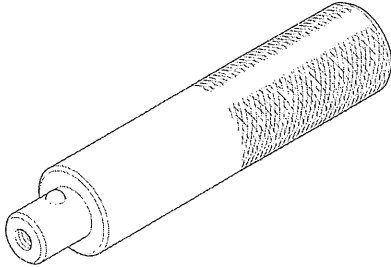
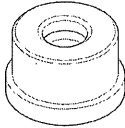
<p>Driver 07749-0010000</p> 	<p>Attachment, 32 × 35 mm 07746-0010100</p> 
---	---

### TROUBLESHOOTING

#### Engine oil level too low

- Oil consumption
- External oil leak
- Worn piston rings (page 11-8)
- Incorrect piston ring installation (page 11-9)
- Worn cylinder (page 11-5)
- Worn valve guide (page 10-16)
- Worn valve stem seal (page 10-14)

#### Oil contamination

- Oil not changed often enough
- Faulty cylinder head gasket
- Worn piston rings (page 11-8)

# OIL PUMP

## REMOVAL

- When removing the oil pump, do not allow dust or dirt to enter the engine.

Drain the engine oil (page 3-12).  
Remove the stator (page 14-4).

Remove the bolts [1] and stator base [2].

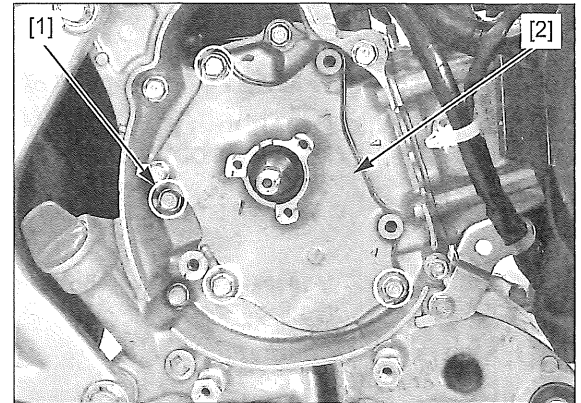

Remove the O-ring [1] from the stator base groove.  
Remove the dowel pins [2] from right crankcase.

Remove the oil pump driven gear [3].

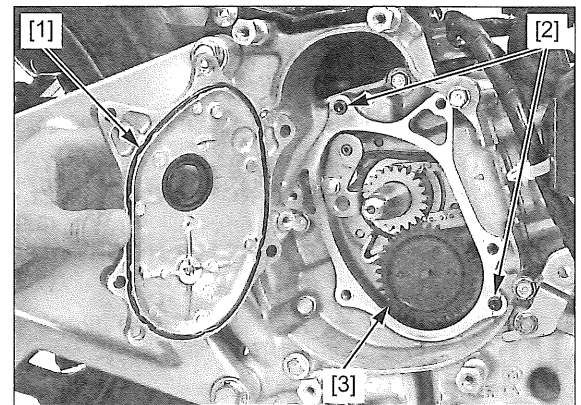

Remove the oil pump mounting bolts [1] and oil pump [2].

Remove the dowel pins [3].

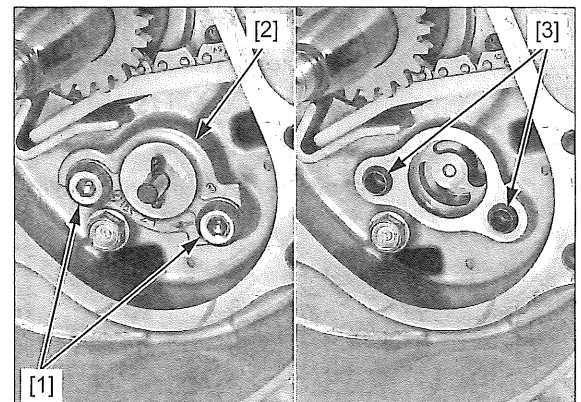

Remove the outer rotor [1] from the oil pump assembly [2].

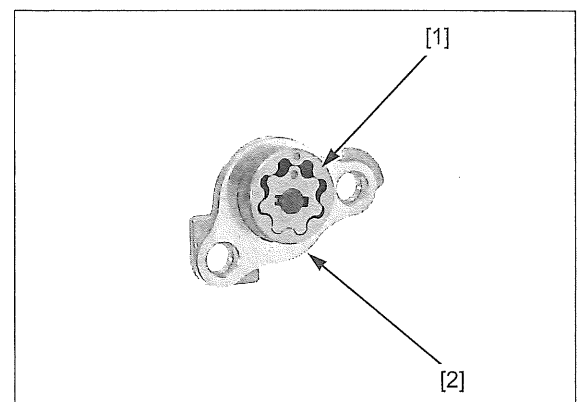

# LUBRICATION SYSTEM

## INSPECTION

- If any clearance of the oil pump exceeds the specified service limits, replace the oil pump as an assembly.

### OIL PUMP BODY (RIGHT CRANKCASE)

Check the oil pump body sliding surface for wear or damage.

Measure the I.D. and depth of oil pump body.

#### STANDARD:

**OIL PUMP BODY I.D.:** 23.150 – 23.180 mm  
(0.9114 – 0.9126 in)

**OIL PUMP BODY DEPTH:** 7.020 – 7.090 mm  
(0.2764 – 0.2791 in)

- Measure at several points and use the largest reading.

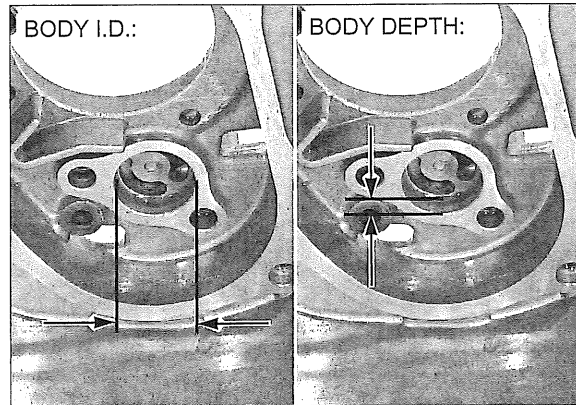

### OUTER ROTOR

Check the oil pump outer rotor sliding surface for wear or damage.

Measure the O.D. and height of outer rotor.

#### STANDARD:

**OUTER ROTOR O.D.:** 22.970 – 23.000 mm  
(0.9043 – 0.9055 in)

**OUTER ROTOR HEIGHT:** 6.960 – 6.980 mm  
(0.2740 – 0.2748 in)

- Measure at several points and use the smallest reading.

Calculate the oil pump body-to-outer rotor clearance.

**SERVICE LIMIT: 0.35 mm (0.014 in)**

Calculate the side clearance.

**SERVICE LIMIT: 0.15 mm (0.006 in)**

### INNER ROTOR

Check the oil pump inner rotor [1] sliding surface for wear or damage.

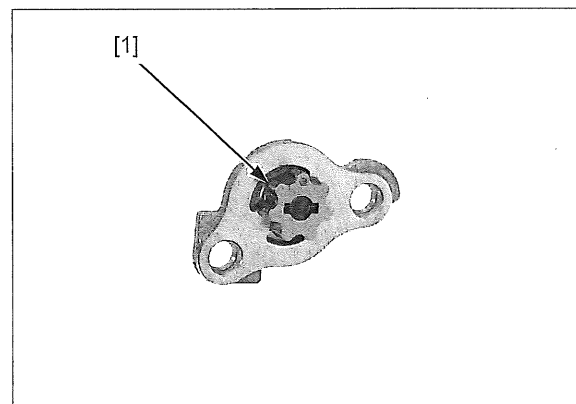
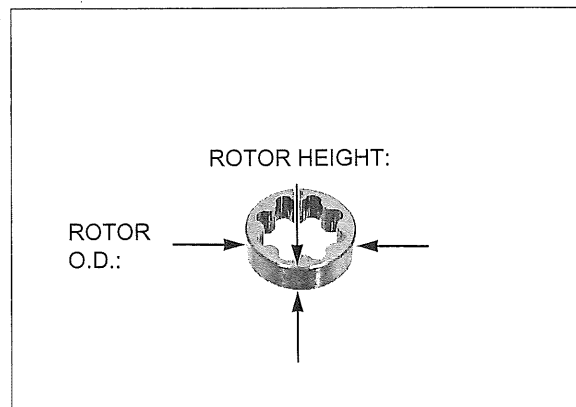



### RIGHT CRANKSHAFT OIL SEAL INSPECTION/REPLACEMENT

Check the condition of the right crankshaft oil seal [1].  
If damaged or deteriorated, replace as follows.

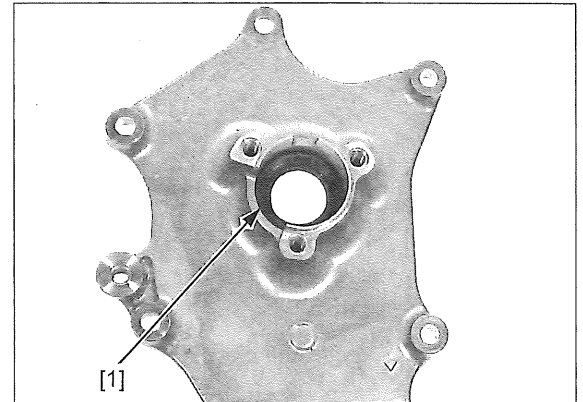

Apply engine oil to a new oil seal [1] lip.  
Install the oil seal to the stator base squarely until it is flush with the stator base surface as shown, using the special tools.

**TOOLS:**

- [2] Driver 07749-001000
- [3] Attachment, 32 x 35 mm 07746-001010

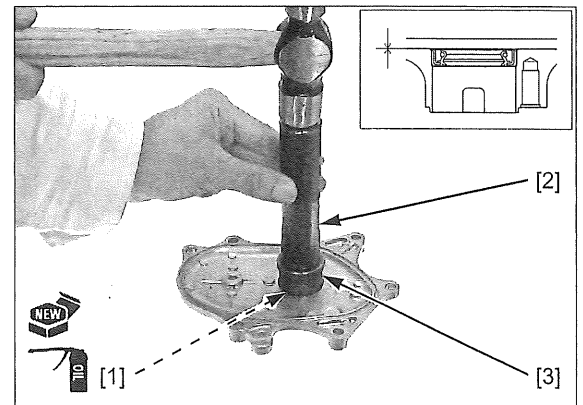

### INSTALLATION

Apply engine oil to the entire surface of the inner [1] and outer [2] rotors and to the oil pump shaft [3] sliding surface.  
Install the outer rotor to the oil pump assembly [4].

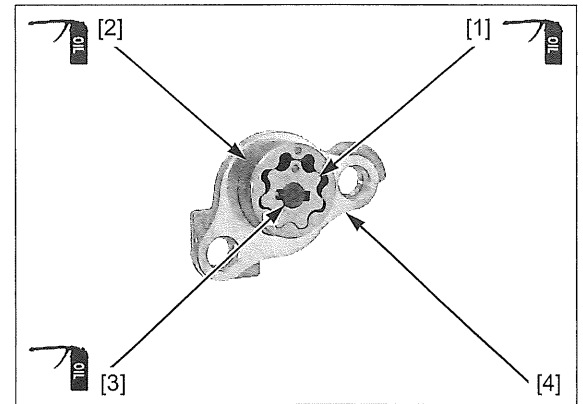

Install the dowel pins [1].  
Install the oil pump [2] to the crankcase.  
Install and tighten the oil pump mounting bolts [3] to the specified torque.

**TORQUE: 10 N·m (1.0 kgf·m, 7 lbf·ft)**

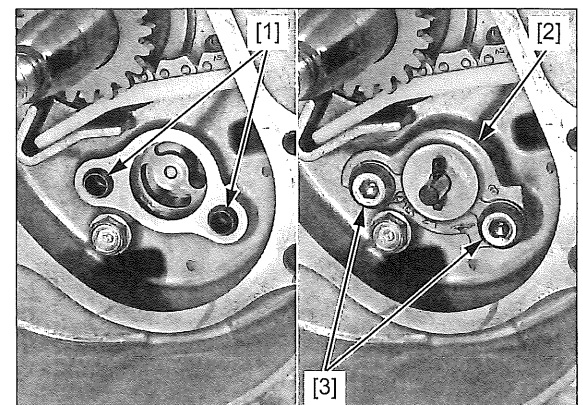

## LUBRICATION SYSTEM

Apply engine oil to the oil pump drive [1] and driven [2] gear teeth.  
Apply engine oil to the oil pump shaft [3] sliding surface.  
Install the oil pump driven gear by aligning its groove with the oil pump shaft pin.

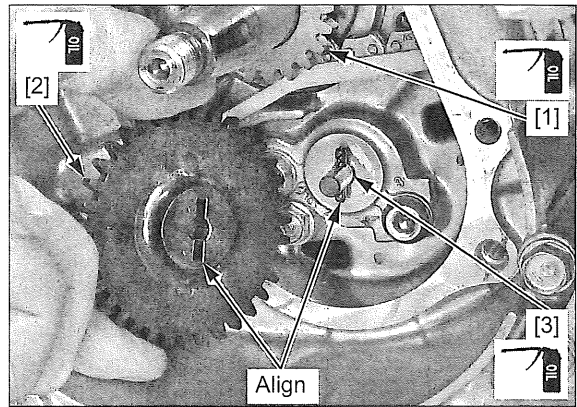

Install the dowel pins [1] to the right crankcase.  
Apply engine oil to a new O-ring [2].  
Install the O-ring to the stator base groove.  
Apply engine oil to the right crankshaft oil seal [3] lips.

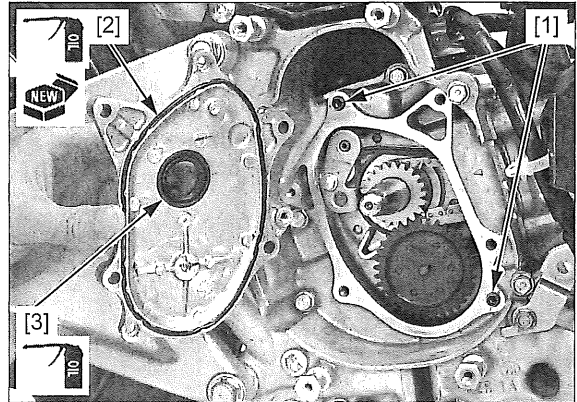

Install the stator base [1] and tighten the bolts [2].  
Install the stator (page 14-6).  
Fill the engine oil (page 3-12).

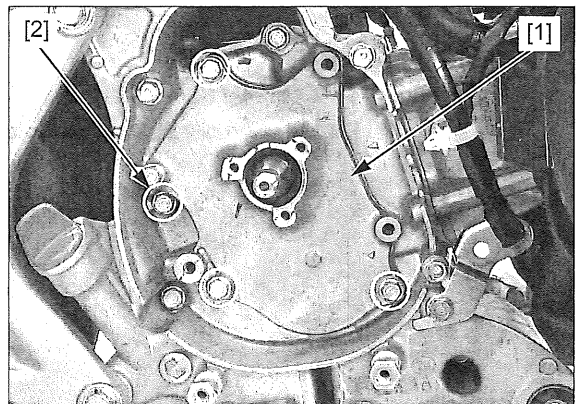

# 9. COOLING SYSTEM

---

SYSTEM FLOW PATTERN .....	9-2	COOLANT REPLACEMENT .....	9-5
SERVICE INFORMATION .....	9-3	RADIATOR .....	9-6
TROUBLESHOOTING .....	9-3	RADIATOR RESERVE TANK .....	9-7
COOLING SYSTEM TESTING .....	9-4	WATER PUMP/THERMOSTAT .....	9-8

# COOLING SYSTEM

## SYSTEM FLOW PATTERN

When the engine is cold:

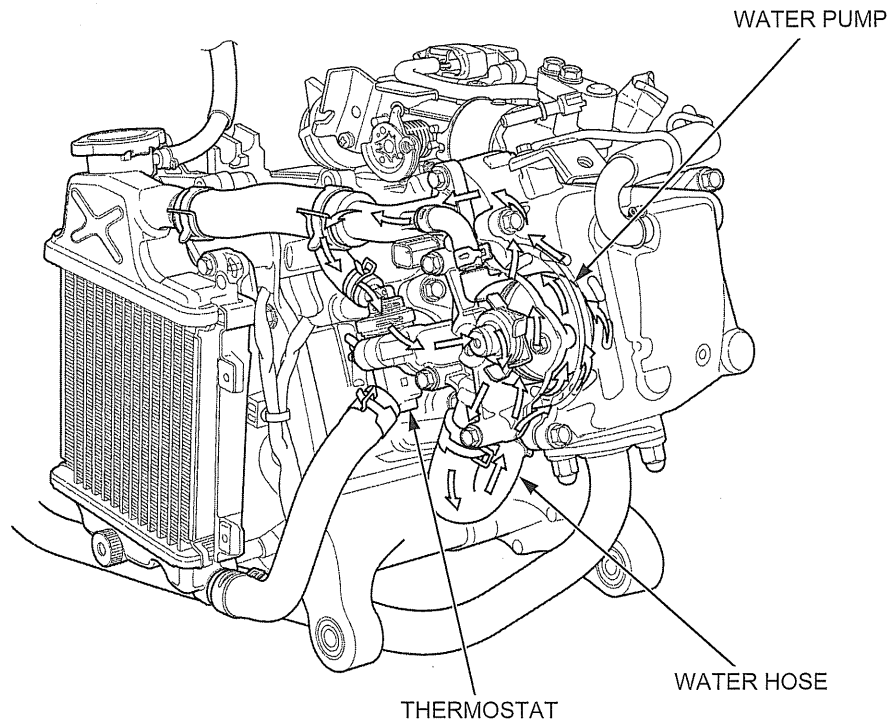

When the engine is hot:

'13 model shown:

RADIATOR RESERVE  
TANK DRAIN HOSE

RESERVE TANK

SIPHON HOSE

WATER PUMP

RADIATOR

THERMOSTAT

WATER HOSE

# SERVICE INFORMATION

## GENERAL

### ⚠ WARNING

Removing the radiator cap while the engine is hot can allow the coolant to spray out, seriously scalding you. Always let the engine and radiator cool down before removing the radiator cap.

### NOTICE

Using coolant with silicate corrosion inhibitors may cause premature wear of water pump seals or blockage of radiator passages. Using tap water may cause engine damage.

- Add coolant at the reserve tank. Do not remove the radiator cap except to refill or drain the system.
- All cooling system can be serviced with the engine in the frame.
- Avoid spilling coolant on painted surfaces.
- After servicing the system, check for leaks with a cooling system tester.

## SPECIFICATIONS

ITEM		SPECIFICATIONS	
Coolant capacity	Radiator and engine	0.48 liter (0.51 US qt, 0.42 Imp qt)	
	Reserve tank	'13 model	0.18 liter (0.19 US qt, 0.16 Imp qt)
		After '13 model	0.054 liter (0.057 US qt, 0.047 Imp qt)
Radiator cap relief pressure		108 – 137 kPa (1.1 – 1.4 kgf/cm <sup>2</sup> , 16 – 20 psi)	
Thermostat	Begin to open	'13 model	74 – 78 °C (165 – 172 °F)
		After '13 model	84 – 88 °C (183 – 190 °F)
	Fully open	'13 model	100 °C (212 °F)
		After '13 model	95 °C (203 °F)
	Valve lift	'13 model	8 mm (0.3 in) minimum
		After '13 model	5.3 mm (0.2 in) minimum
Recommended antifreeze		Pro Honda HP Coolant or an equivalent high quality ethylene glycol antifreeze containing silicate-free corrosion inhibitors	
Standard coolant concentration		1:1 (mixture with distilled water)	

## TORQUE VALUES

ITEM	Q'TY	THREAD DIA. (mm)	TORQUE N·m (kgf·m, lbf·ft)	REMARKS
Radiator drain bolt	1	10	1 (0.1, 0.7)	
Radiator base screw	1	4	0.8 (0.08, 0.6)	
Radiator top cover screw	4	4	3.2 (0.33, 2.4)	

## TROUBLESHOOTING

### Engine temperature too high

- Thermostat stuck closed
- Faulty radiator cap
- Insufficient coolant
- Passage blocked in radiator, hoses or water jacket
- Air in system
- Faulty water pump

### Engine temperature too low

- Thermostat stuck open

### Coolant leak

- Deteriorated O-rings
- Faulty radiator cap
- Damaged or deteriorated cylinder head gasket
- Loose hose connection or clamp
- Damaged or deteriorated hoses

## COOLING SYSTEM

### COOLING SYSTEM TESTING

#### RADIATOR CAP/SYSTEM PRESSURE INSPECTION

Remove the right side cover (page 2-8).

Remove the three bolts [1] and radiator cover [2].

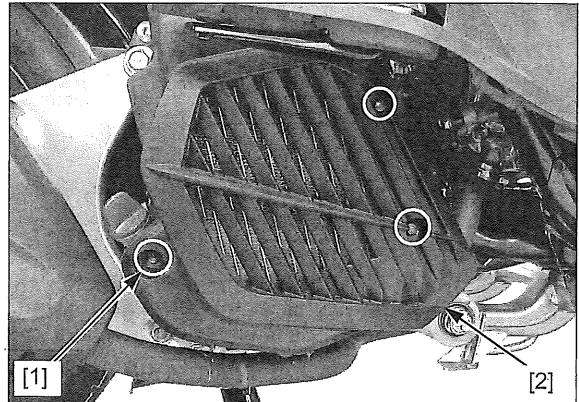

Pinch the siphon hose [1] using a hose clamp [2].  
Remove the radiator cap [3].

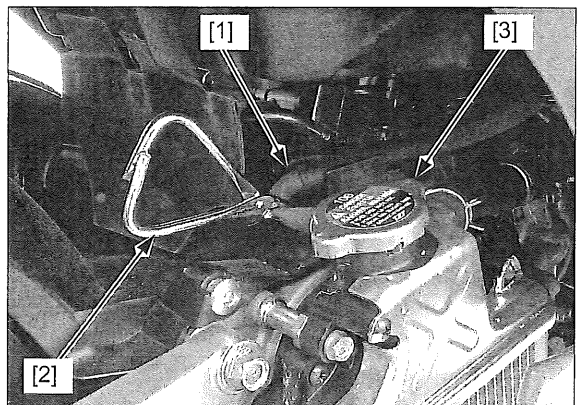

Wet the sealing surfaces of the cap [1], then install the cap onto the tester [2].

Pressurize the radiator cap using the tester.  
Replace the radiator cap if it does not hold pressure, or if relief pressure is too high or too low.  
The cap must hold the specified pressure for at least 6 seconds.

**RADIATOR CAP RELIEF PRESSURE:**  
**108 – 137 kPa (1.1 – 1.4 kgf/cm<sup>2</sup>, 16 – 20 psi)**

Pressurize the radiator, engine and hoses using the tester, and check for leaks.

Repair or replace components if the system will not hold the specified pressure for at least 6 seconds.

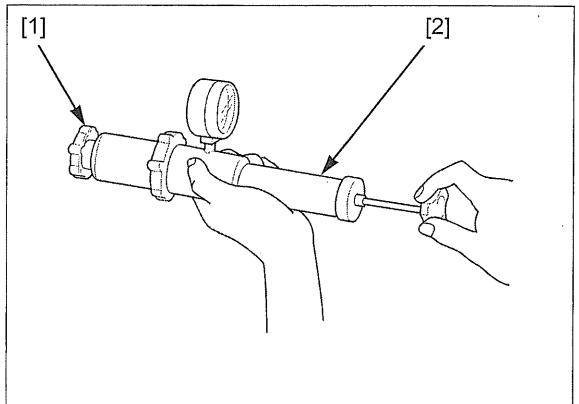

#### NOTICE

*Excessive pressure can damage the cooling system components. Do not exceed 137 kPa.*

Install the removed parts in the reverse order of removal.

# COOLANT REPLACEMENT

## REPLACEMENT/AIR BLEEDING

**NOTE:**

- When filling the system or reserve tank with coolant, or checking the coolant level, support the scooter with its centerstand on a flat, level surface.

Remove the radiator cover (page 9-4).

Remove the radiator drain bolt [1] and O-ring [2] and drain the coolant from the radiator.

Remove the radiator cap [3].

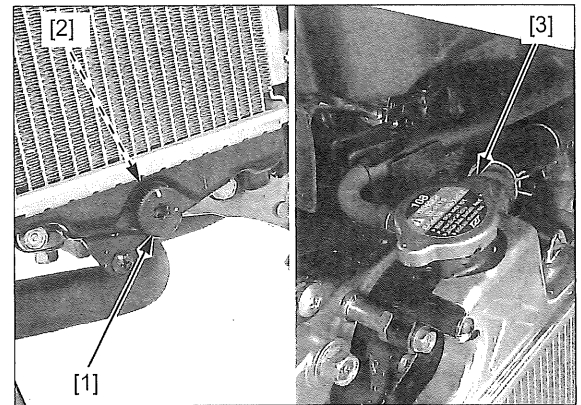

Remove the drain bolt [1] with sealing washer [2] from the cylinder and drain the coolant from the engine.

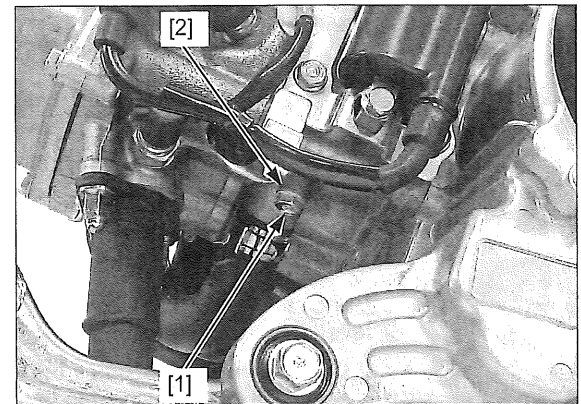

Reinstall the drain bolt [1] with a new sealing washer [2] onto the cylinder.

*Do not apply engine oil to this O-ring.*

Reinstall the radiator drain bolt [3] with a new O-ring [4] onto the radiator and tighten it to the specified torque.

**TORQUE: 1 N·m (0.1 kgf·m, 0.7 lbf·ft)**

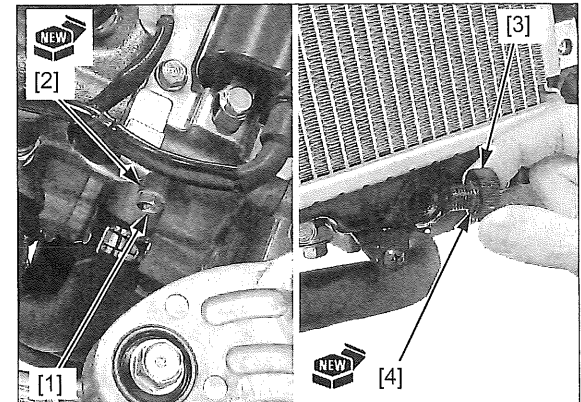

*When filling the system or reserve tank with coolant, or checking the coolant level, support the scooter with its centerstand on a flat, level surface.*

Fill the system with the coolant through the filler opening to the filler neck [1].

**RECOMMENDED ANTIFREEZE:**

**Pro Honda HP Coolant or an equivalent high quality ethylene glycol antifreeze containing silicate-free corrosion inhibitors**

**STANDARD COOLANT CONCENTRATION:**

**1:1 (mixture with distilled water)**

Bleed air from the system as follows:

1. Start the engine and let it idle for 2 – 3 minutes.
2. Snap the throttle three or four times to bleed air from the system.
3. Stop the engine and add coolant up to the filler neck.
4. Reinstall the radiator cap [2].

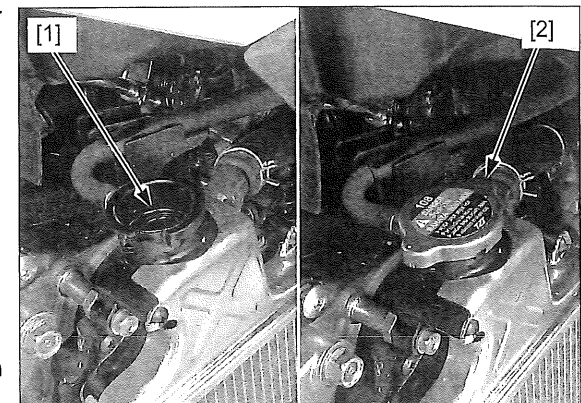

## COOLING SYSTEM

'13 model: Unlock and open the seat.  
Remove the trim clip [1] and radiator reserve tank lid [2].  
Remove the reserve tank cap [3].  
Fill the reserve tank with the coolant to the upper level line [4].  
Install the removed parts in the reverse order of removal.

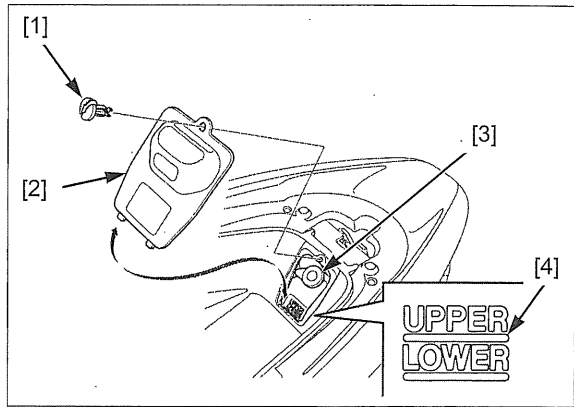

After '13 model: Support the scooter with its centerstand.  
Check the coolant level of the reserve tank with the engine running at normal operating temperature. The level should be between the "UPPER" level line and "LOWER" level line with the scooter upright on a level surface.  
If the level is low, fill as follows:  
Remove the radiator reserve tank lid [1].  
Remove the reserve tank cap [2] and fill the tank to the "UPPER" level line with a recommend antifreeze.

### RECOMMENDED ANTIFREEZE:

**High quality ethylene glycol antifreeze containing silicate-free corrosion inhibitors**

Check if there are any coolant leaks when the coolant level decreases very rapidly.

If the reserve tank becomes completely empty, there is a possibility of air getting into the cooling system.

Be sure to remove all air from the cooling system (page 9-5).

Install the radiator reserve tank lid.

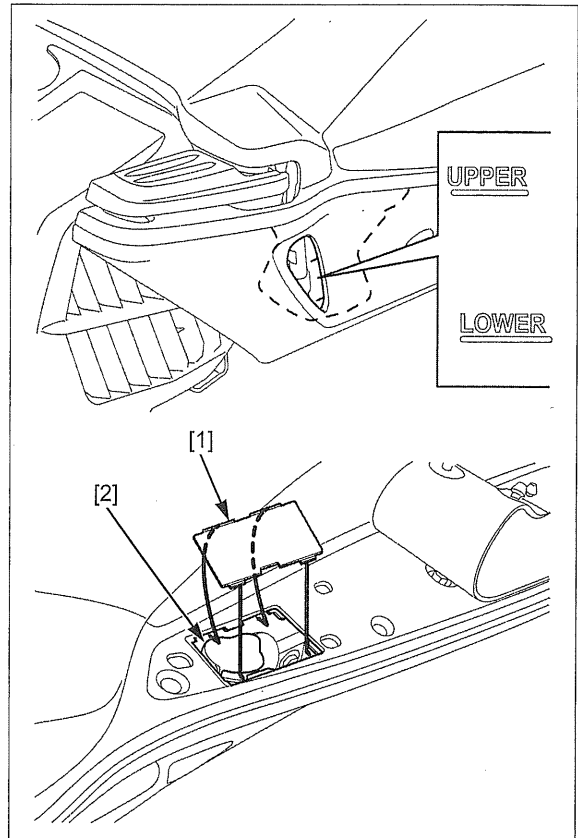

## RADIATOR

### REMOVAL/INSTALLATION

Drain the coolant (page 9-5).  
Disconnect the water hose [1] from the radiator.  
Release the wire band boss [2].  
Disconnect the siphon hose [3] and water hose [4] from the radiator.

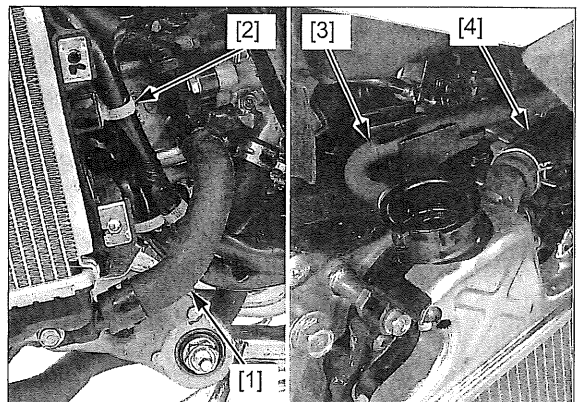



Be careful not to damage the fins while servicing the radiator. Make sure that the hose clips are installed in the correct direction (page 1-25).

Remove the four radiator mounting bolts [1] and radiator [2]. Installation is in the reverse order of removal. Fill and bleed the cooling system (page 9-5). After installation, make sure the coolant does not leak.

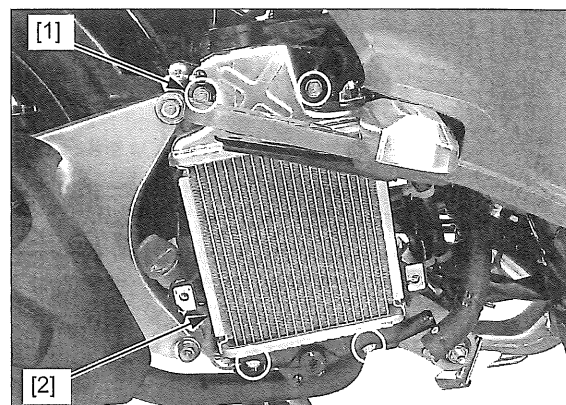

## RADIATOR RESERVE TANK

### REMOVAL/INSTALLATION ('13 MODEL)

Remove the luggage box (page 2-25). Disconnect the overflow hose [1] from the reserve tank [2]. Remove the special bolt [3].

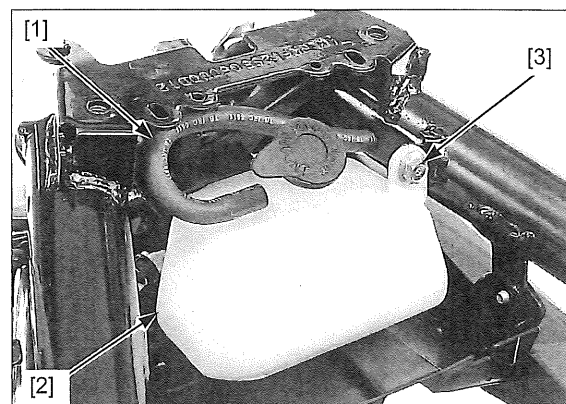

Remove the reserve tank [1] by releasing the boss [2] from the groove [3] of the rear fender.

Open the reserve tank cap [4] and drain the coolant into an approved pan.

Disconnect the siphon hose [5] from the reserve tank.

Installation is in the reverse order of removal.

- After installation, fill the reserve tank with the coolant (page 9-6).

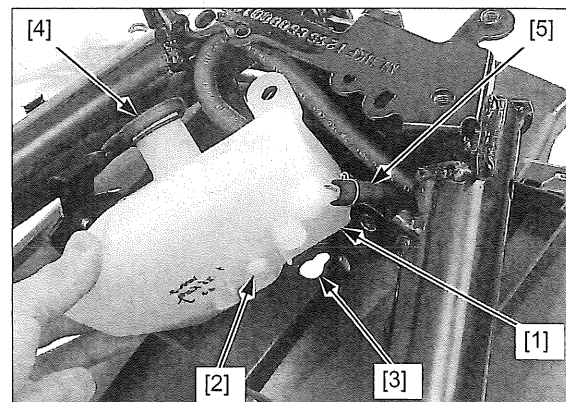

### REMOVAL/INSTALLATION (AFTER '13 MODEL)

Remove the right side cover (page 2-8).

Disconnect the siphon hose [1] from the reserve tank [2] and drain the reserve coolant.

Remove the bolt [3] and reserve tank.

Installation is in the reverse order of removal.

- After installation, fill the reserve tank with the coolant (page 9-6).

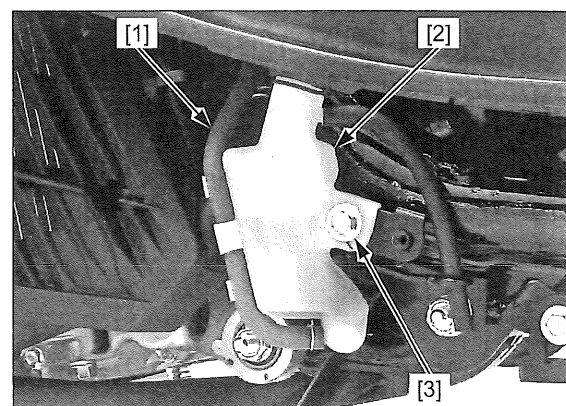

# WATER PUMP/THERMOSTAT

## MECHANICAL SEAL INSPECTION

The water pump bleed hole is located in the lower side of water pump [1] joint area with cylinder head.

If there is coolant leakage around this area, remove the water pump (page 9-8).

Check the bleed hole of the water pump for signs of coolant leakage [2].

If the coolant is leaking out from the bleed hole, the mechanical seal in the water pump assembly is faulty. Replace the water pump as an assembly.

- A small amount of weeping from the bleed hole is normal.
- Make sure that there is no continuous coolant leakage from the bleed hole while operating the engine.

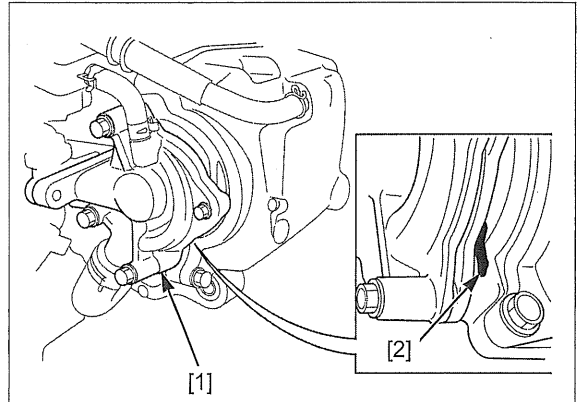

## REMOVAL/DISASSEMBLY

- The water pump can be serviced with the engine installed on the frame.

Drain the coolant (page 9-5).

Remove the right side cover (page 2-8).

Disconnect the water hoses [1] from the water pump and thermostat.

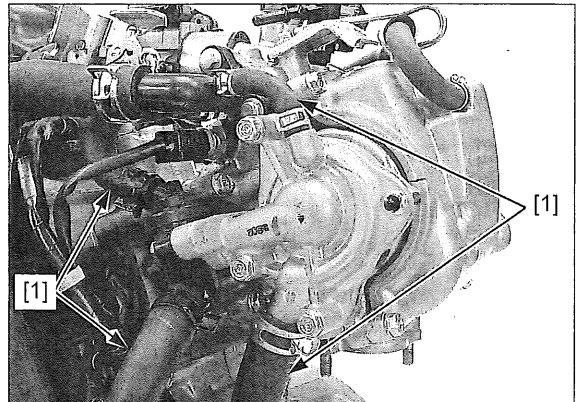

Loosen the water pump cover bolt [1].

Remove the three bolts [2] and water pump/thermostat [3].

Remove the O-ring [4].

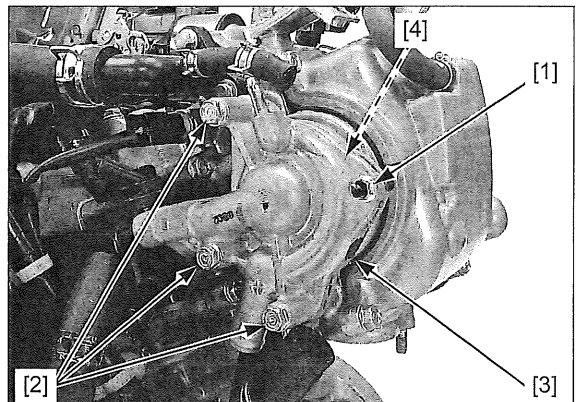

Remove the water pump cover bolt [1], water pump cover/thermostat [2] and dowel pins [3].

Remove the O-ring [4].

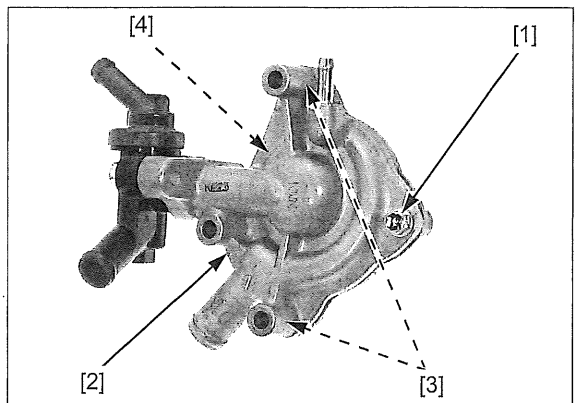

Remove the two bolts [1], thermostat [2] and O-ring [3] from the water pump cover [4].

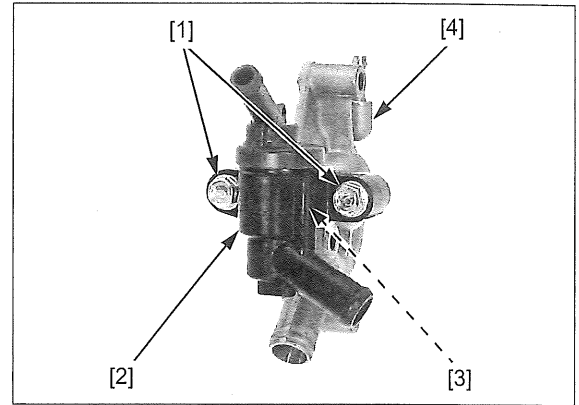

**THERMOSTAT INSPECTION**

Visually inspect the thermostat [1] for damage. Replace the thermostat if it stays open at room temperature.

*Wear insulated gloves and adequate eye protection. Keep flammable materials away from the electric heating element. Do not let the thermostat or thermometer [2] touch the pan, or you will get a false reading.*

Heat a container of water with an electric heating element for 5 minutes.

Suspend the thermostat in heated water to check its operation.

**VALVE BEGINS TO LIFT (OPEN):**

'13 model: 74 – 78 °C (165 – 172 °F)  
After '13 model: 84 – 88 °C (183 – 190 °F)

**VALVE LIFT:**

'13 model: 8 mm (0.3 in) minimum at 100 °C (212 °F)  
After '13 model: 5.3 mm (0.2 in) minimum at 95 °C (203 °F)

Replace the thermostat if the valve opens at temperature other than specified.

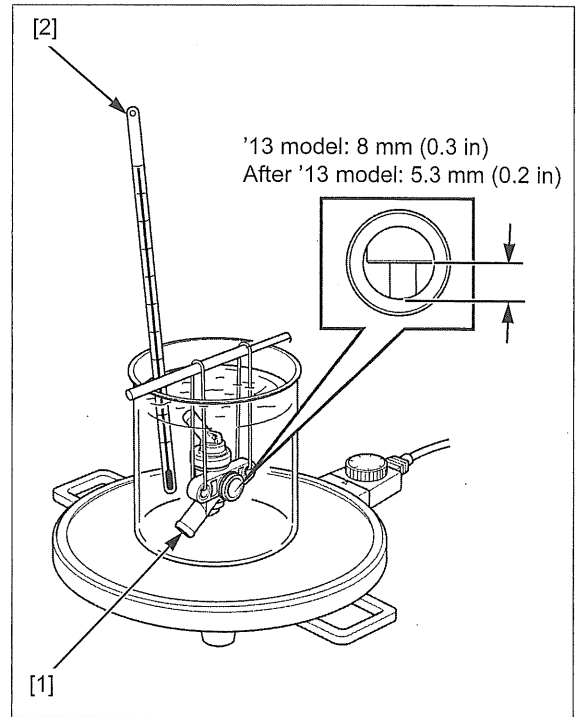

# COOLING SYSTEM

## ASSEMBLY/INSTALLATION

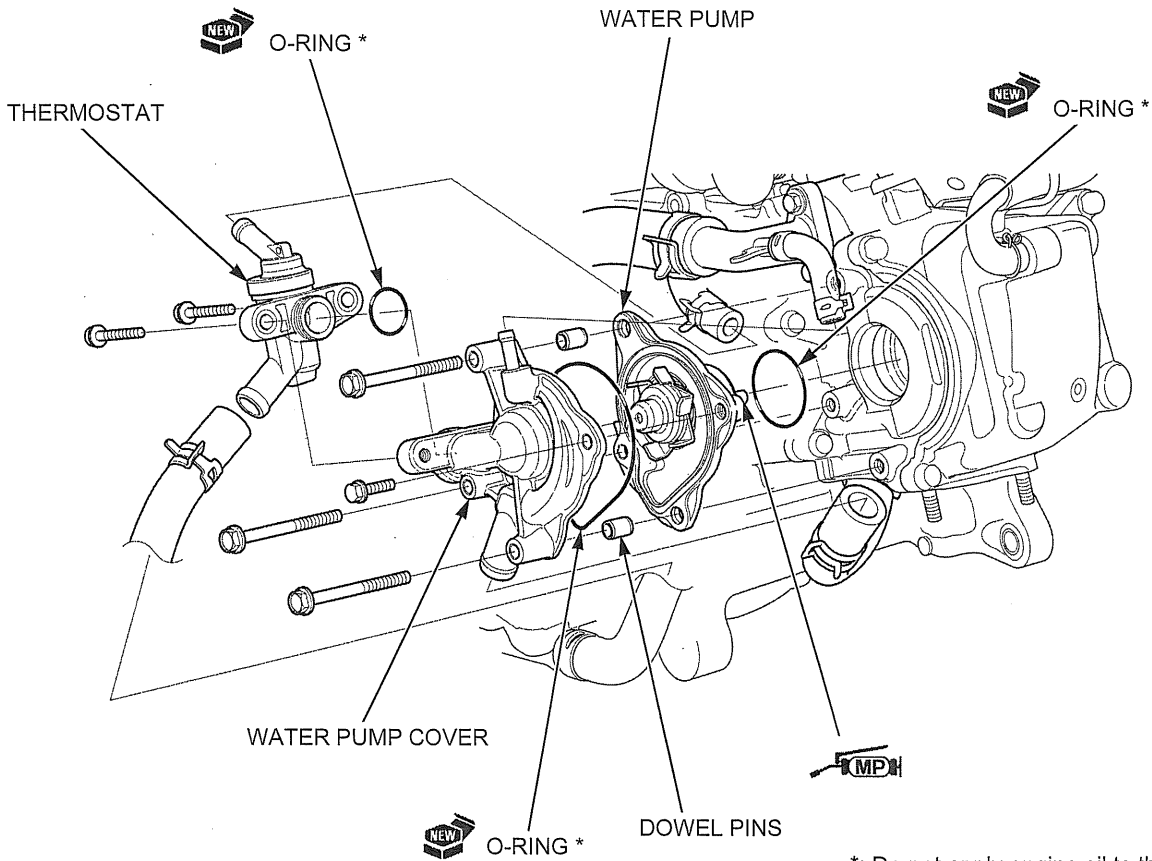

\*: Do not apply engine oil to these O-rings.

*Do not apply engine oil to this O-ring.* Install a new O-ring [1] into the groove of the thermostat [2].

Install the thermostat to the water pump cover and tighten the bolts [3].

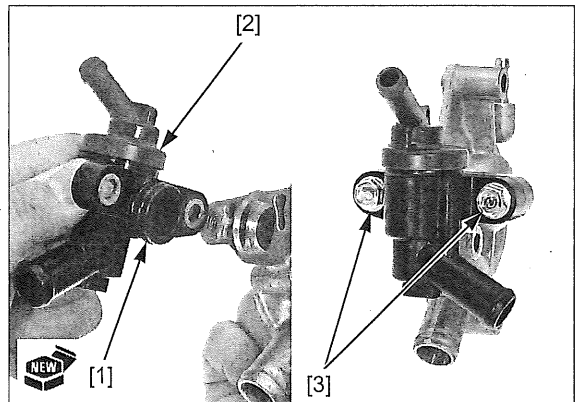

*Do not apply engine oil to this O-ring.* Install a new O-ring [1] into the groove of the water pump [2]. Install the two dowel pins [3] to the water pump cover. Install the water pump cover/thermostat [4] to the water pump.

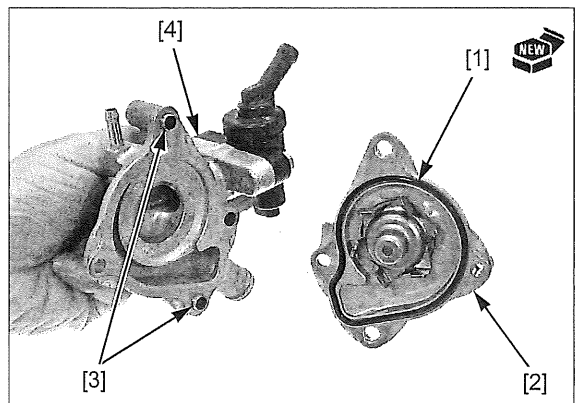

Temporarily install the water pump cover bolt [1], but do not tighten it yet.

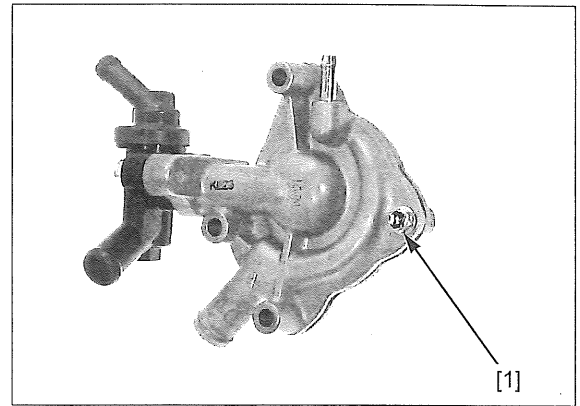

Apply liquid sealant (Three Bond 5211C or 1215 or SHIN-ETSU-SILICONE KE45T or LOCTITE 5060S or 5020 or equivalent) to the specified area as shown.

*Do not apply engine oil to this O-ring.*

Install a new O-ring [1] into the groove of the water pump.

Apply molybdenum disulfide paste (SUMICO MOLYPASTE 300 or equivalent) to the water pump shaft mating area with the camshaft.

Install the water pump/thermostat assembly [2] to the cylinder head while aligning the pin on the water pump shaft with the groove on the camshaft.

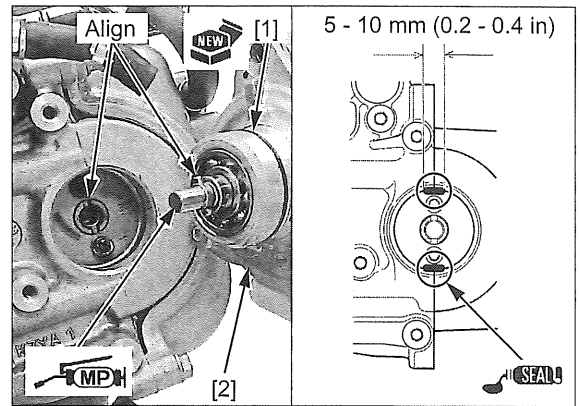

Install and tighten the three water pump mounting bolts [1], then tighten the water pump cover bolt [2].

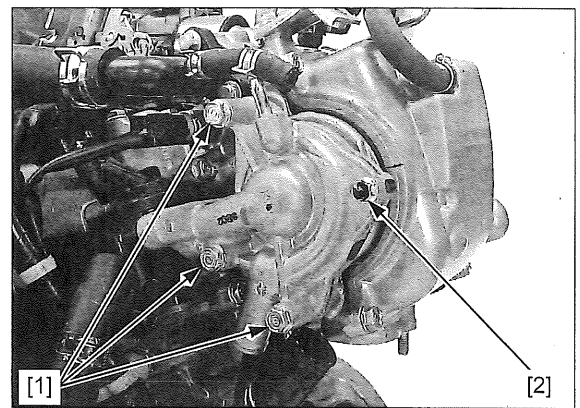

*Make sure that the hoses and clips are installed in the correct direction (page 1-25).*

Connect the water hoses [1] to the water pump and thermostat.

Fill and bleed the cooling system (page 9-5).

Install the right side cover (page 2-8).

After installation, make sure the coolant does not leak.

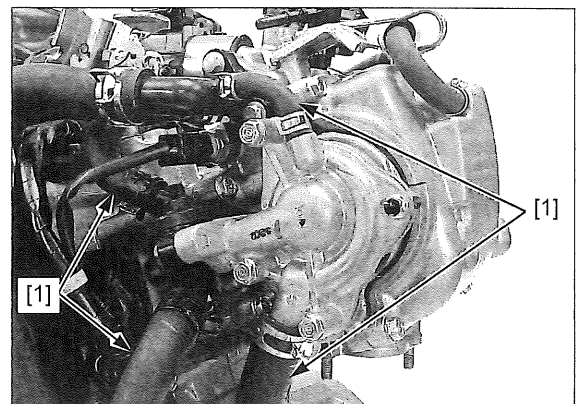

---

**MEMO**

---

# 10. CYLINDER HEAD/VALVES

---

COMPONENT LOCATION .....	10-2	CYLINDER HEAD COVER .....	10-6
SERVICE INFORMATION .....	10-3	CAMSHAFT .....	10-8
TROUBLESHOOTING .....	10-5	CYLINDER HEAD .....	10-13
CYLINDER COMPRESSION TEST .....	10-6	CAM CHAIN TENSIONER LIFTER .....	10-23

# CYLINDER HEAD/VALVES

## COMPONENT LOCATION

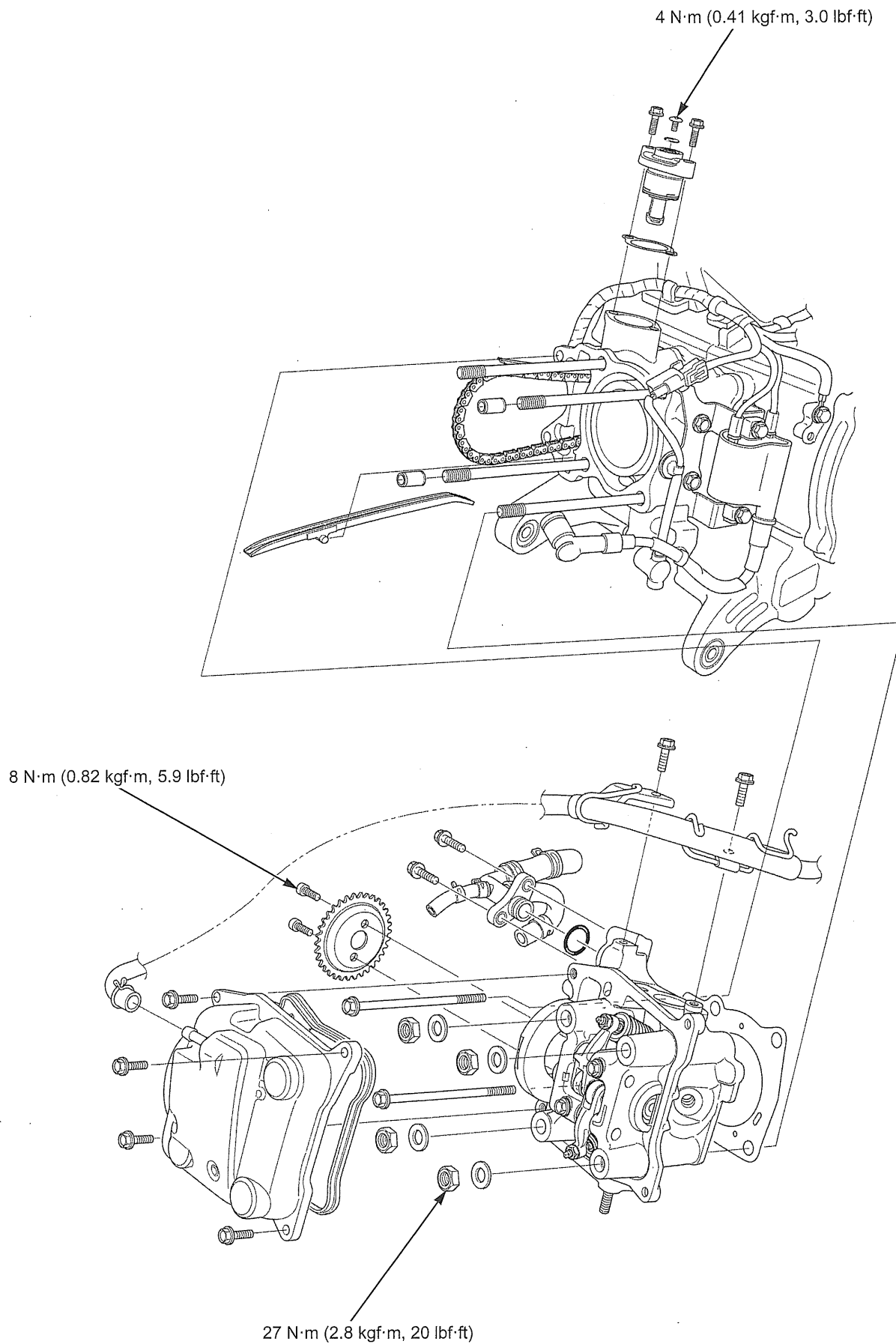



## SERVICE INFORMATION

### GENERAL

- This section covers service of the cylinder head, valves, rocker arms, camshaft and cam chain tensioner.
- The rocker arms, camshaft, and cam chain tensioner services can be done with the engine installed in the frame. The cylinder head service requires engine removal.
- When disassembling, mark and store the disassembled parts to ensure that they are reinstalled in their original locations.
- Clean all disassembled parts with cleaning solvent and dry them by blowing them off with compressed air before inspection.
- Camshaft and rocker arm lubricating oil is fed through oil passages in the cylinder head. Clean the oil passages before assembling cylinder head.
- Be careful not to damage the mating surfaces when removing the cylinder head cover and cylinder head. Do not tap the cylinder head cover and cylinder head too hard during removal.

### SPECIFICATIONS





ITEM		STANDARD	SERVICE LIMIT
Cylinder compression		1,098 kPa (11.2 kgf/cm <sup>2</sup> , 159.3 psi) at 850 rpm	–
Cylinder head warpage		–	0.05 (0.002)
Rocker arm shaft O.D.		IN/EX	–
Camshaft	Cam lobe height	IN	33.616 – 33.856 (1.3235 – 1.3329)
		EX	33.393 – 33.633 (1.3147 – 1.3241)
Valve, valve guide	Valve clearance	IN	0.10 ± 0.02 (0.004 ± 0.001)
		EX	0.24 ± 0.02 (0.009 ± 0.001)
	Valve stem O.D.	IN	4.975 – 4.990 (0.1959 – 0.1965)
		EX	4.955 – 4.970 (0.1951 – 0.1957)
	Valve guide I.D.	IN/EX	5.000 – 5.012 (0.1969 – 0.1973)
	Stem-to-guide clearance	IN	0.010 – 0.037 (0.0004 – 0.0015)
		EX	0.030 – 0.057 (0.0012 – 0.0022)
	Valve guide projection above cylinder head	IN/EX	11.05 – 11.35 (0.435 – 0.447)
Valve seat width	IN/EX	0.90 – 1.10 (0.035 – 0.043)	
Valve spring free length		IN/EX	36.94 (1.454)

### TORQUE VALUES

ITEM	Q'TY	THREAD DIA. (mm)	TORQUE N·m (kgf·m, lbf·ft)	REMARKS
Camshaft stopper bolt	1	6	10 (1.0, 7)	
Rocker arm shaft stopper bolt	2	5	5 (0.51, 3.7)	Apply oil to the threads and seating surface.
Cam sprocket socket bolt	2	5	8 (0.82, 5.9)	Apply oil to the threads and seating surface.
Cam chain tensioner lifter screw	1	6	4 (0.41, 3.0)	
Water pump holder bolt	2	6	10 (1.0, 7)	
Cylinder head nut	4	8	27 (2.8, 20)	Apply oil to the threads and seating surface.
Cylinder head sealing bolt	1	12	32 (3.3, 24)	

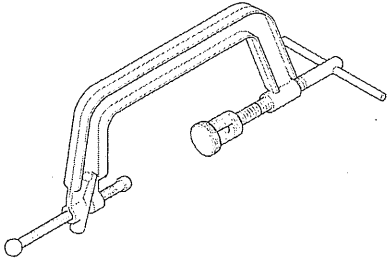
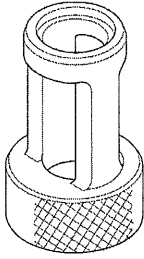
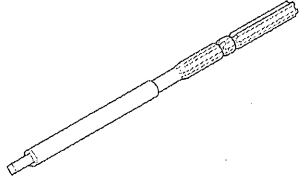
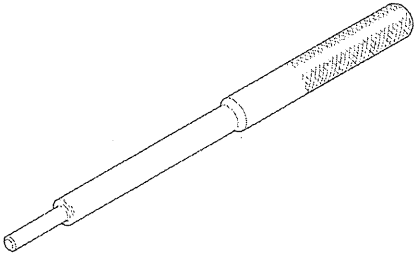
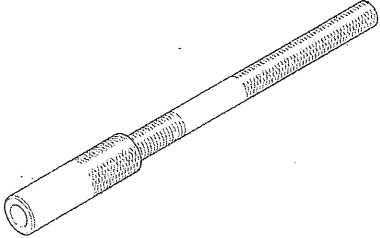
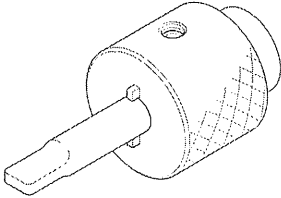
# CYLINDER HEAD/VALVES

## TOOLS

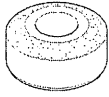
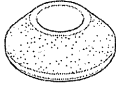
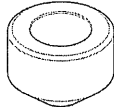
<p>Valve spring compressor 07757-0010000</p> 	<p>Valve spring compressor attachment 07959-KM30101</p> 	<p>Valve guide reamer, 5.0 mm 07984-MA60001</p>  <p>or 07984-MA6000D (U.S.A. only)</p>
<p>Valve guide driver, 5.0 mm 07942-MA60000</p> 	<p>Valve guide adjusting driver 07743-0020000</p>  <p>(Not available in U.S.A.)</p>	<p>Tensioner holder 070MG-0010100</p>  <p>or 07AMG-001A100 (U.S.A. only)</p>
<p>Seat cutter, 29 mm (IN, 45°) 07780-0010300</p>  <p>or equivalent commercially available in U.S.A.</p>	<p>Seat cutter, 27.5 mm (EX, 45°) 07780-0010200</p>  <p>or equivalent commercially available in U.S.A.</p>	<p>Flat cutter, 30 mm (IN, 32°) 07780-0012200</p>  <p>or equivalent commercially available in U.S.A.</p>
<p>Flat cutter, 27 mm (EX, 32°) 07780-0013300</p>  <p>or equivalent commercially available in U.S.A.</p>	<p>Interior cutter, 30 mm (IN, 60°) 07780-0014000</p>  <p>or equivalent commercially available in U.S.A.</p>	<p>Interior cutter, 24 mm (EX, 60°) 070PH-Z0D0100</p>  <p>or equivalent commercially available in U.S.A.</p>

Cutter holder 5.0 mm  
07781-0010400

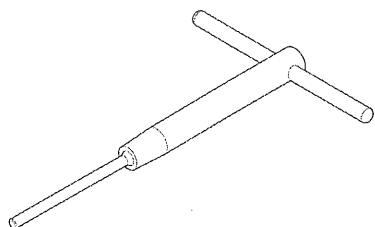

or equivalent commercially available in  
U.S.A.

## TROUBLESHOOTING

- Engine top-end problems usually affect engine performance. These can be diagnosed by a compression test or by tracing engine noises to the top-end with a sounding rod or stethoscope.
- If the performance is poor at low speeds, check for white smoke in the crankcase breather hose. If the hose is smoky, check for a seized piston ring (page 11-8).

### Compression too low, hard starting or poor performance at low speed

- Valves:
  - Incorrect valve adjustment
  - Burned or bent valve
  - Incorrect valve timing
  - Broken valve spring
  - Uneven valve seating
  - Valve stuck open
  - Weak valve spring
- Cylinder head:
  - Leaking or damaged cylinder head gasket
  - Warped or cracked cylinder head
  - Loose spark plug
- Worn cylinder (page 11-5).
- Worn piston or piston rings (page 11-8).

### Compression too high, overheating or knocking

- Excessive carbon build-up on piston head or on combustion chamber

### Excessive smoke

- Worn valve stem or valve guide
- Damaged stem seal
- Worn cylinder (page 11-5).
- Worn piston or piston rings (page 11-8).

### Excessive noise

- Incorrect valve adjustment
- Sticking valve or broken valve stem
- Excessively worn valve seat
- Worn or damaged camshaft
- Worn or damaged cam chain
- Worn cam sprocket teeth
- Worn rocker arm and/or shaft
- Worn or damaged cam chain tensioner
- Worn cylinder (page 11-5).
- Worn piston or piston rings (page 11-8).

### Rough idle

- Low cylinder compression

## CYLINDER HEAD/VALVES

### CYLINDER COMPRESSION TEST

Warm up the engine to normal operating temperature. Stop the engine and remove the spark plug cap and spark plug (page 3-9).

Install a compression gauge [1] into the spark plug hole.

*To avoid discharging the battery, do not operate the starter for more than 7 seconds.*

Open the throttle all the way and crank the engine with the starter until the gauge reading stops rising. The maximum reading is usually reached within 4 – 7 seconds.

#### COMPRESSION PRESSURE:

**1,098 kPa (11.2 kgf/cm<sup>2</sup>, 159.3 psi) at 850 rpm**

If compression is high, it indicates that carbon deposits have accumulated on the combustion chamber and/or the piston crown.

If compression is low, pour 3 – 5 cm<sup>3</sup> of clean engine oil into the cylinder through the spark plug hole and recheck the compression.

If the compression increases from the previous value, check the cylinder, piston and piston rings.

- Leaking cylinder head gasket
- Worn piston ring
- Worn cylinder and piston

If compression is the same as the previous value, check the valves for leakage.

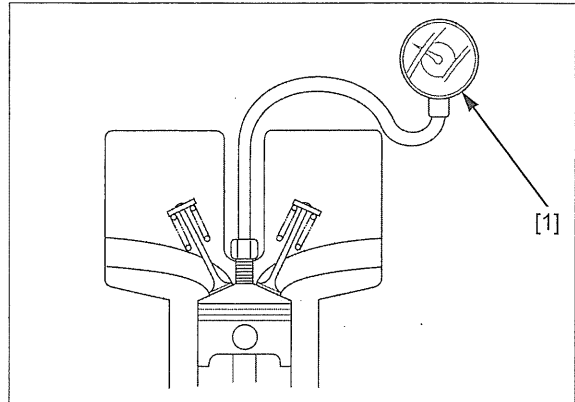

### CYLINDER HEAD COVER

#### REMOVAL

Remove the battery box (page 2-26).

Disconnect the crankcase breather hose [1] from the cylinder head cover.

Remove the bolt [2] and release the hose clamp [3].

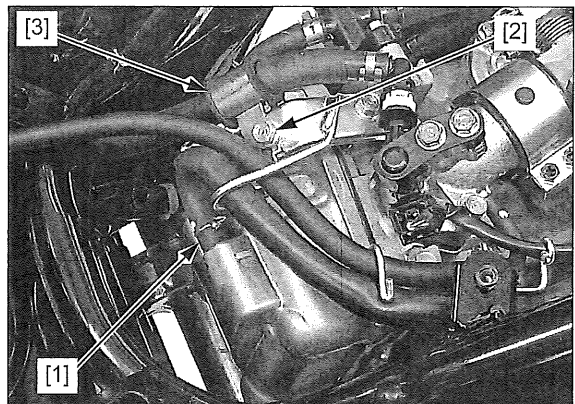

Remove the bolts [1], cylinder head cover [2] and rubber seal [3].

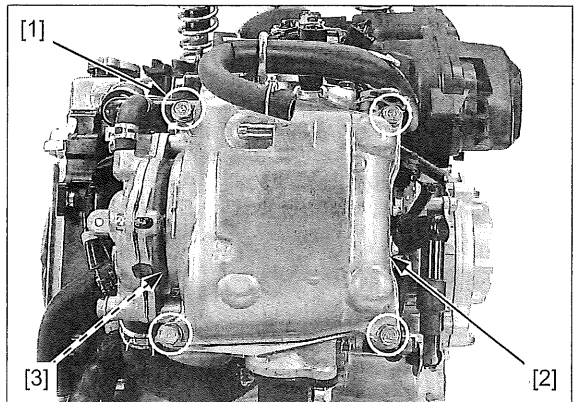

**INSTALLATION**

Make sure the cylinder head cover rubber seal [1] is in good condition and replace it if necessary.

Install the rubber seal into the groove on the cylinder head cover [2].

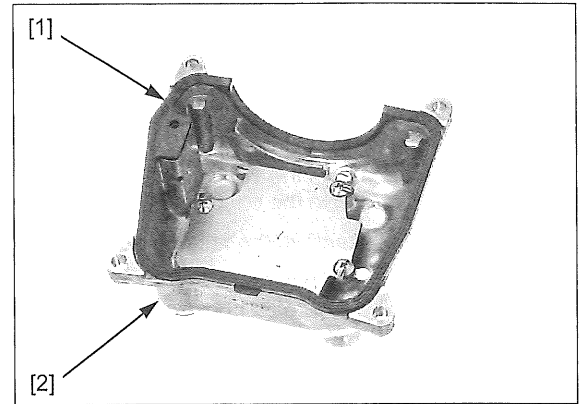

Apply liquid sealant (Three Bond 5211C or 1215 or SHIN-ETSU-SILICONE KE45T or LOCTITE 5060S or 5020 or equivalent) to the cylinder head and rubber seal mating surface as shown.

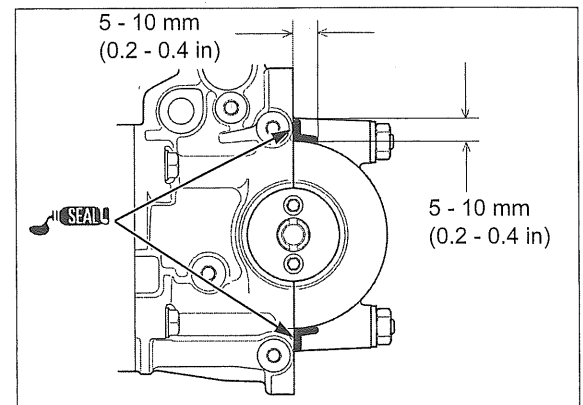

Install the cylinder head cover [1] onto the cylinder head.

Install the bolts [2] and tighten them.

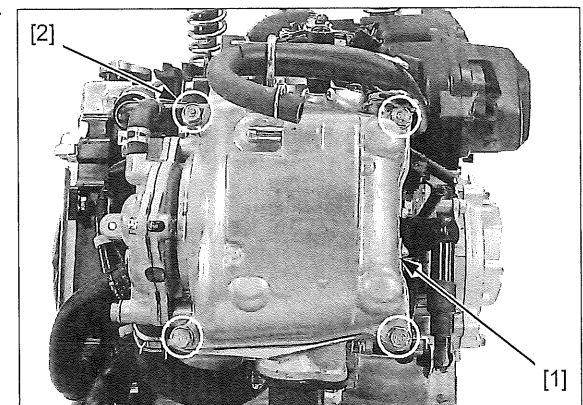

Set the hose guide [1], then install and tighten the bolt [2].

Connect the crankcase breather hose [3].

Install the battery box (page 2-26).

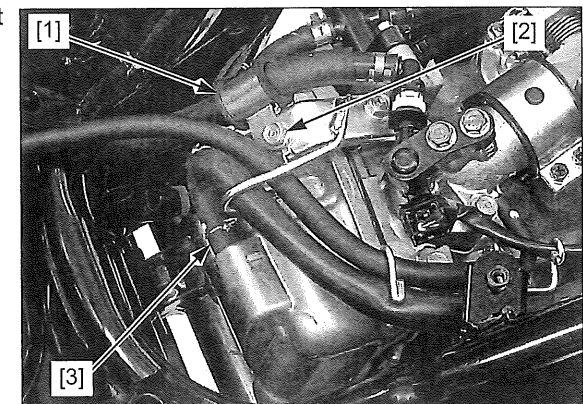

## CAMSHAFT

### REMOVAL

#### NOTE:

Camshaft can be serviced with the engine installed in the frame.

Drain the coolant (page 9-5).

Drain the engine oil (page 3-12).

Remove the following:

- Body cover (page 2-23)
- Throttle body (page 7-15)
- Cylinder head cover (page 10-6)
- Water pump (page 9-8)

Set the piston to the TDC (Top Dead Center) on the compression stroke (page 3-10).

Make sure that the index lines [1] on the cam sprocket are flush with the top surface of cylinder head and that the "KWN" mark [2] on the cam sprocket is facing up as shown (TDC on the compression stroke).

If the cam sprocket "KWN" mark is not facing up, rotate the crankshaft one full turn and realign the index lines on the cam sprocket.

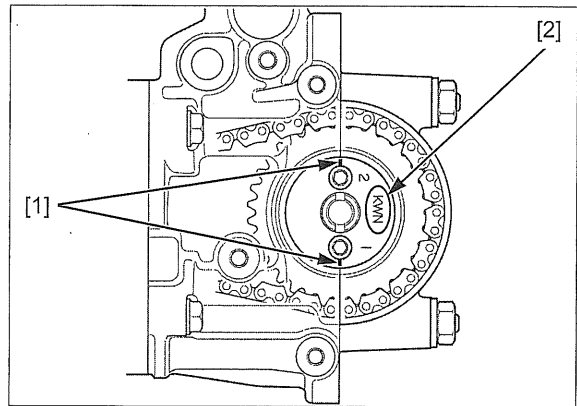

Remove the cam chain tensioner lifter screw [1] and O-ring [2].

Install the special tool [3] into the tensioner body and turn the tool clockwise until it stops turning. Hold the tensioner lifter by pushing the tool while aligning the tabs of the tool with the grooves of the tensioner lifter.

#### TOOL:

[3] Tensioner holder

070MG-0010100 or  
07AMG-001A100  
(U.S.A. only)

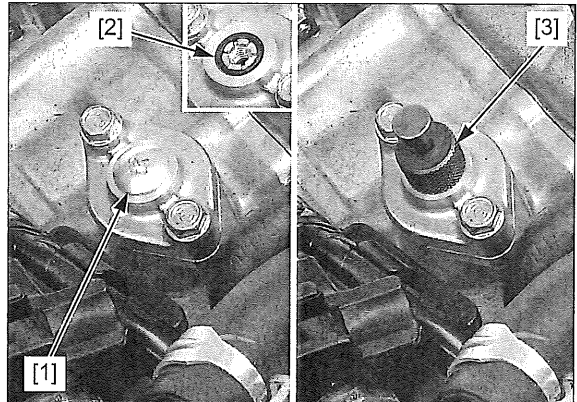

*Place a shop towel at the opening of the crankcase to prevent the cam sprocket bolt from falling into the crankcase.*

Remove the bolts [1], cam sprocket [2] from the camshaft and cam chain [3] off the cam sprocket.

Attach a piece of wire to the cam chain to prevent it from falling into the crankcase.

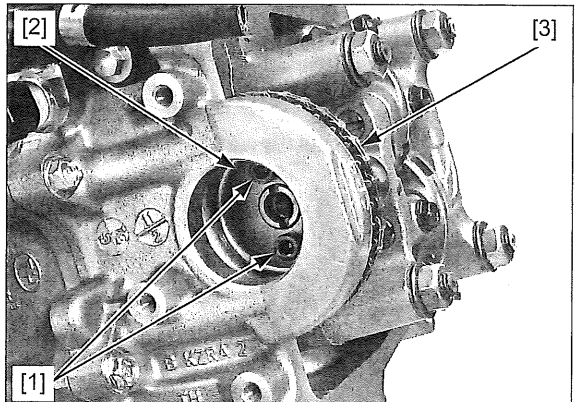

Remove the rocker arm shaft stopper bolts [1]. Push the rocker arm shafts [2] out from the opposite side of the cylinder head and remove the rocker arms [3].

Remove the camshaft stopper bolt/washer [4].

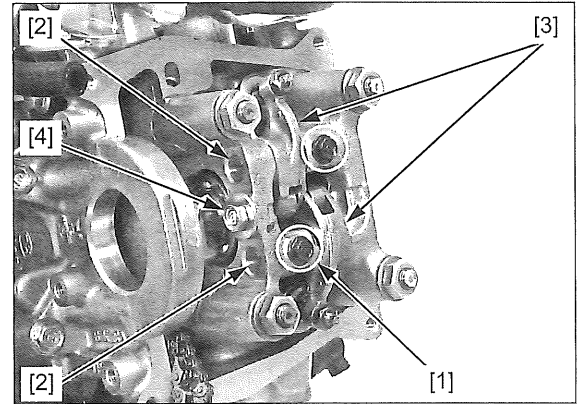

Turn the camshaft 180° so that the tab [1] on the camshaft flange [2] is facing backward, then remove the camshaft from the cylinder head.

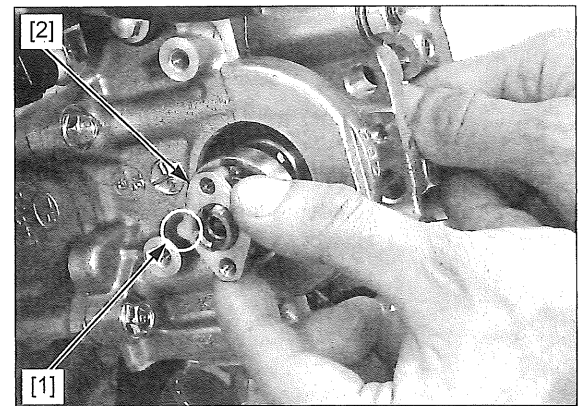

**INSPECTION**

**DECOMPRESSOR SYSTEM**

Turn the decompressor [1] with your finger. Make sure that the decompressor operates smoothly and that the weight returns back in position.

If the decompressor is faulty, replace the camshaft as an assembly.

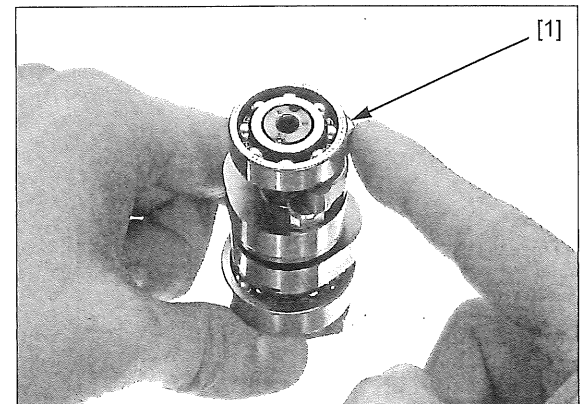

**CAMSHAFT**

Turn the outer race of each camshaft bearing [1] with your finger. The bearing should turn smoothly and quietly.

Also check that the bearing inner race fits tightly on the camshaft.

Replace the camshaft assembly if the bearing does not turn smoothly, quietly, or if they fit loosely on the camshaft.

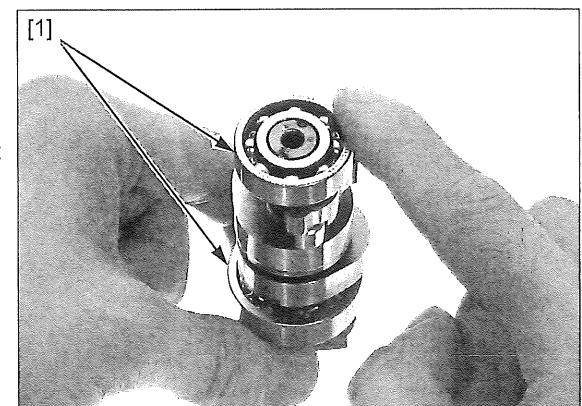

## CYLINDER HEAD/VALVES

Check the cam lobes [1] for excessive wear and damage.

Measure the height of each cam lobe.

### STANDARD:

IN: 33.616 – 33.856 mm (1.3235 – 1.3329 in)

EX: 33.393 – 33.633 mm (1.3147 – 1.3241 in)

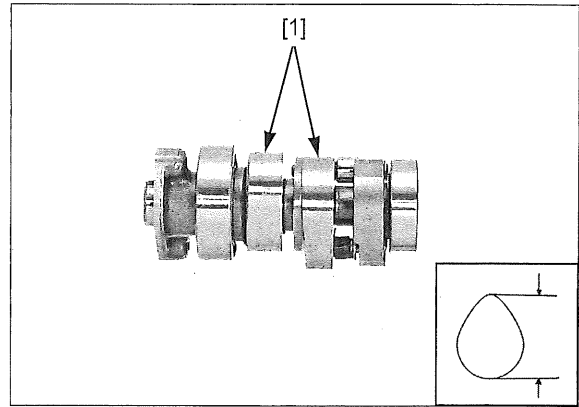

### ROCKER ARM/SHAFT

Check the rocker arm shafts [1] and rocker arms [2] for wear or damage.

Check the needle bearing [3] for wear or damage. Turn the rocker arm rollers [4] with your finger. The rollers should turn smoothly and quietly.

Measure the O.D. of each rocker arm shaft.

### STANDARD:

IN/EX: 9.960 – 9.972 mm (0.3921 – 0.3926 in)

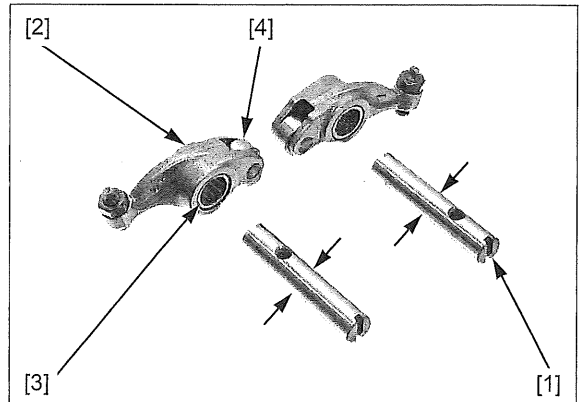

Temporarily install the rocker arm shaft [1] to the rocker arm [2].

Check the rocker arm needle bearing for excessive play and rocker arm shaft for smooth movement.

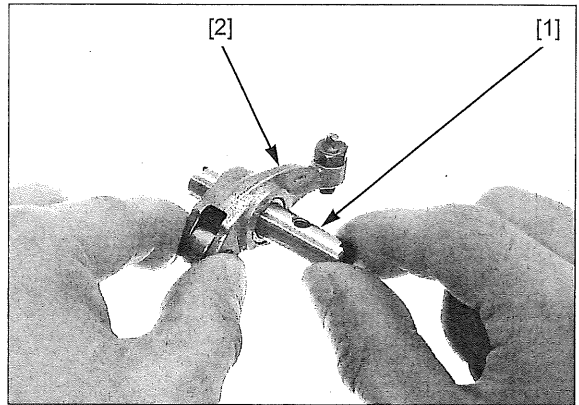

### INSTALLATION

Apply engine oil to the camshaft bearings [1].

Apply molybdenum oil solution to the cam lobes [2], decompressor [3] cam area and rotating surface.

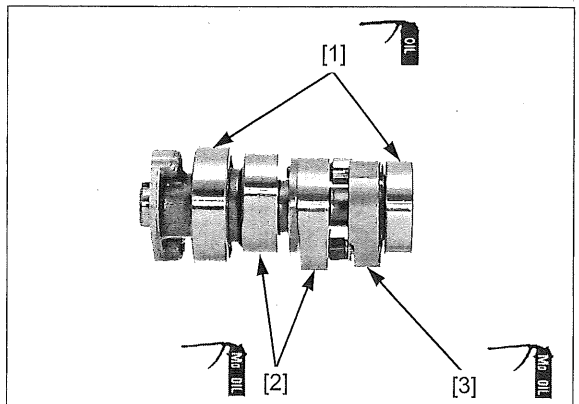



Install the camshaft with its flange tab [1] facing backward.

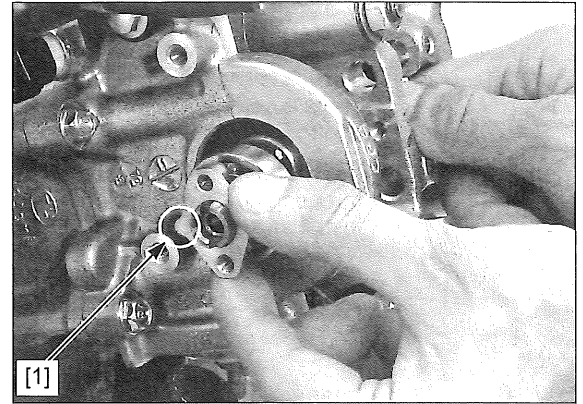

Turn the camshaft 180° so that the tab [1] on the camshaft flange is facing forward as shown. Install and tighten the camshaft stopper bolt [2] to the specified torque.

**TORQUE: 10 N·m (1.0 kgf·m, 7 lbf·ft)**

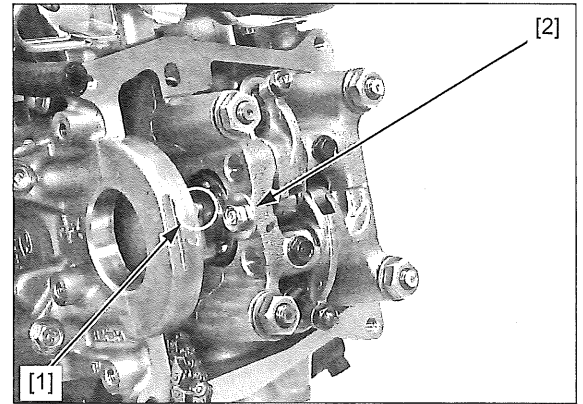

Apply engine oil to the rocker arm [1] roller surface. Apply molybdenum oil solution to the sliding surface of the rocker arm needle bearing [2] and rocker arm shaft [3].

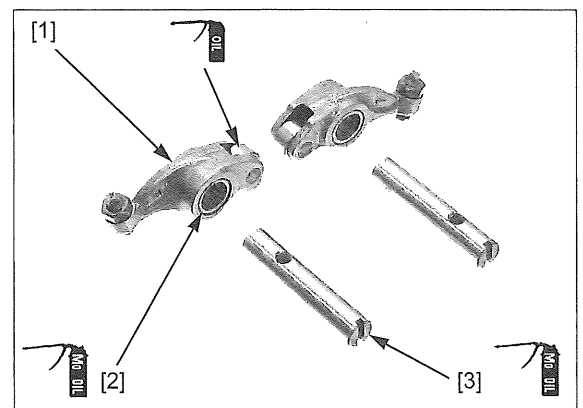

Intake and exhaust rocker arms have identification marks, "I" [1] is for the intake rocker arm and "E" [2] is for the exhaust rocker arm.

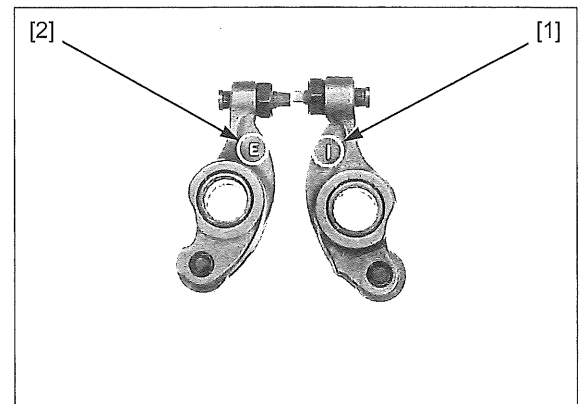

## CYLINDER HEAD/VALVES

Install the intake [1] and exhaust [2] rocker arms to the cylinder head.

Insert the rocker arm shafts [3] into the cylinder head using a screwdriver while aligning the bolt holes of the shaft with the bolt holes on cylinder head.

Apply engine oil to the rocker arm shaft stopper bolts [4] threads and seating surfaces.

Install and tighten the bolts to the specified torque.

**TORQUE: 5 N·m (0.51 kgf·m, 3.7 lbf·ft)**

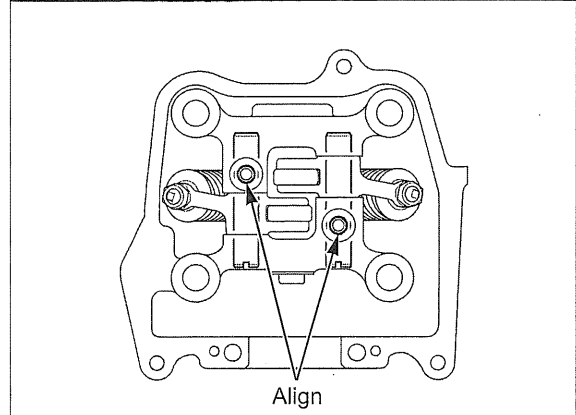
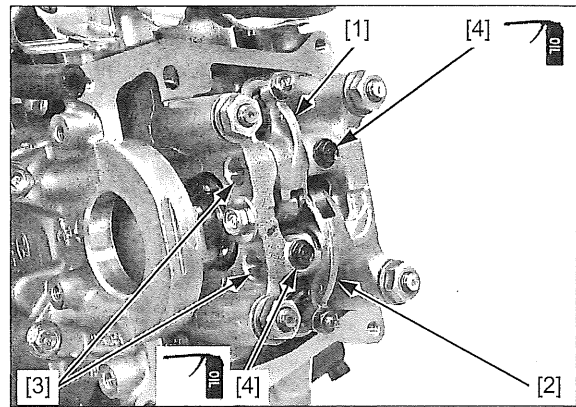

Rotate the crankshaft and align the cut out ("T" mark) [1] on the cooling fan with the index mark [2] on the crankcase.

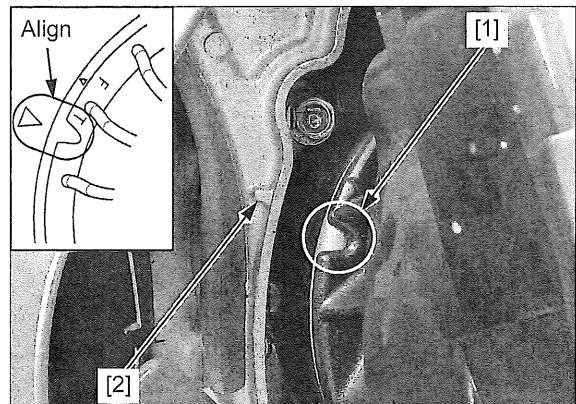

Apply engine oil to the cam chain [1] whole surface and cam sprocket [2] teeth.

Install the cam chain on the cam sprocket.

Install the cam sprocket to the camshaft so that the index lines [3] on the cam sprocket is flush with the cylinder head and "KWN" mark [4] is facing forward as shown (TDC on the compression stroke).

Apply engine oil to the seating surface and thread of the cam sprocket socket bolts [5].

Install and tighten the bolts to specified torque in the sequence of the cam sprocket numbers [6].

**TORQUE: 8 N·m (0.82 kgf·m, 5.9 lbf·ft)**

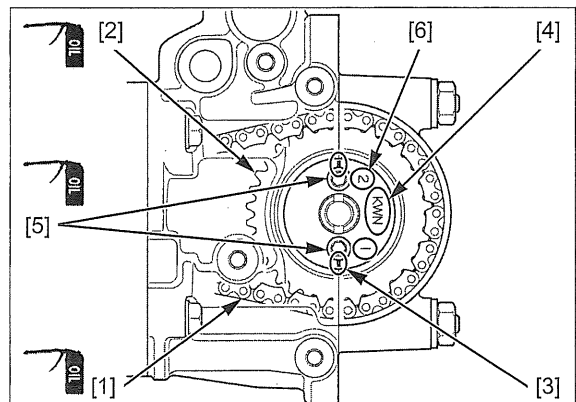

*Place a shop towel at the opening of the crankcase to prevent the cam sprocket bolt from falling into the crankcase.*

Remove the tensioner holder [1].  
 Coat a new O-ring [2] with engine oil and install it into the cam chain tensioner lifter groove.  
 Install and tighten the cam chain tensioner lifter screw [3] to the specified torque.

**TORQUE: 4 N·m (0.41 kgf·m, 3.0 lbf·ft)**

Inspect the valve clearance (page 3-10).

Install the following:

- Water pump (page 9-10)
- Cylinder head cover (page 10-7)
- Throttle body (page 7-19)
- Body cover (page 2-23)

Fill and bleed the coolant (page 9-5).

Fill the engine oil (page 3-12).

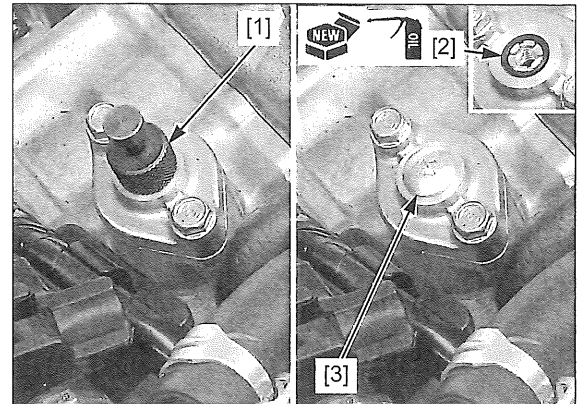

## CYLINDER HEAD

### REMOVAL

Remove the following:

- Engine (page 16-4)
- Camshaft (page 10-8)
- Exhaust pipe/muffler (page 2-28)
- Intake pipe (page 7-25)
- Spark plug (page 3-9)
- O<sub>2</sub> sensor (page 4-53)
- ECT sensor (page 4-52)

Remove the two bolts [1] and water joint [2] from the cylinder head.

Remove the O-ring [3] from the water joint.

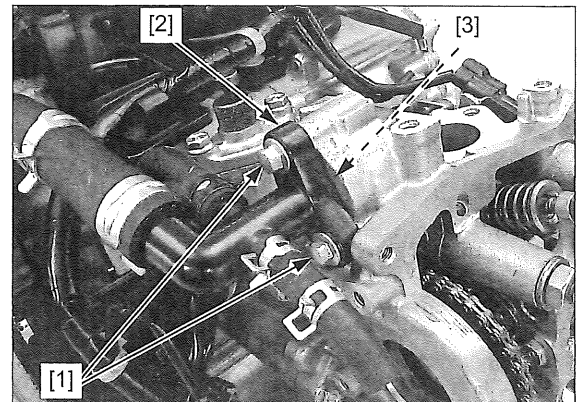

Remove the bolts [1] and wire guides [2] from the cylinder head.

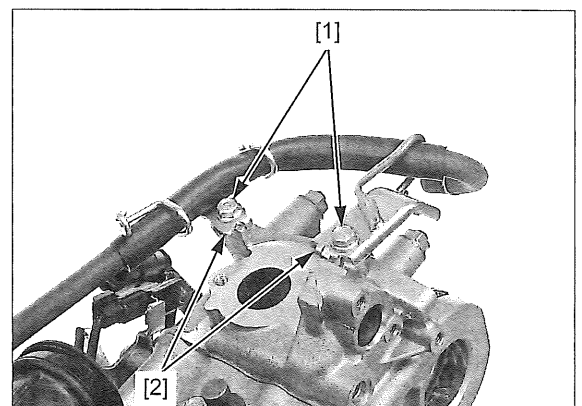

Remove the cylinder head bolts [1].

Loosen the cylinder head nuts [2] in a crisscross pattern in two or three steps.

Remove the nuts and washers [3].

Remove the cylinder head [4].

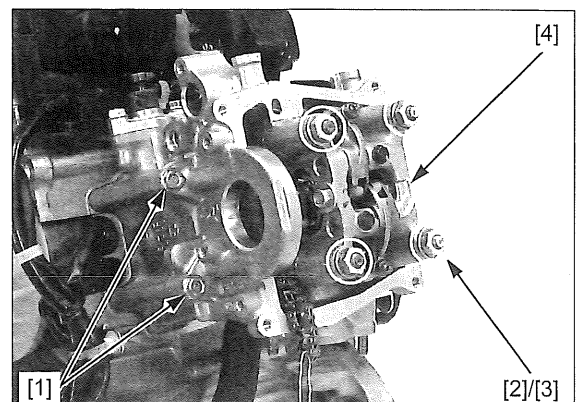

## CYLINDER HEAD/VALVES

*Do not reuse the old gasket.* Remove the gasket [1] and dowel pins [2].  
Remove the cam chain guide [3].

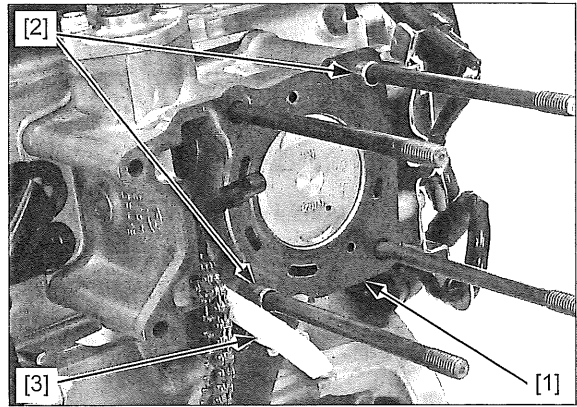

### DISASSEMBLY

Remove the bolts [1] and water pump holder [2].

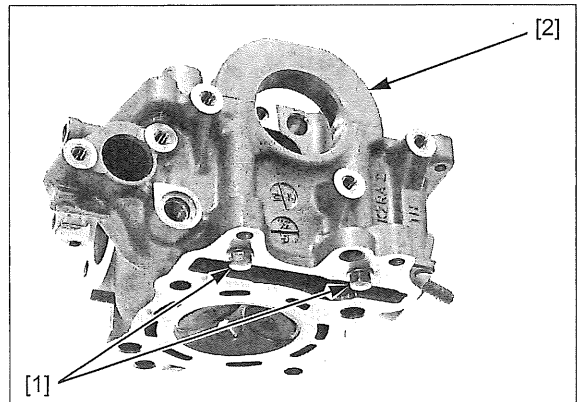

*To prevent loss of tension, do not compress the valve springs more than necessary to remove the cotters.* Remove the valve cotters [1] using the special tool.

#### TOOLS:

[2] Valve spring compressor 07757-0010000  
[3] Valve spring compressor attachment 07959-KM30101

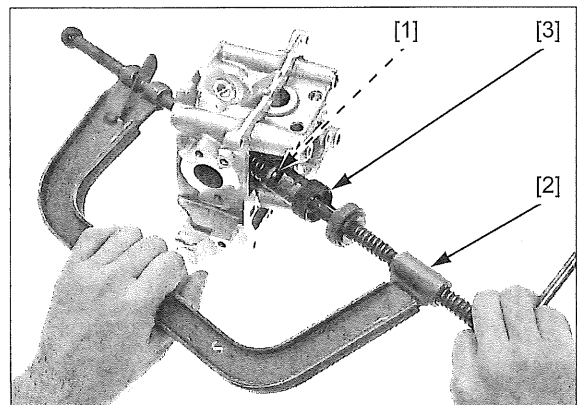

*Mark all parts during disassembly so they can be placed back in their original locations.* Remove the valve spring compressor and remove the following:

- Valve spring retainers [1]
- Valve springs [2]
- Valve spring seats [3]
- Valves [4]
- Valve stem seals [5]

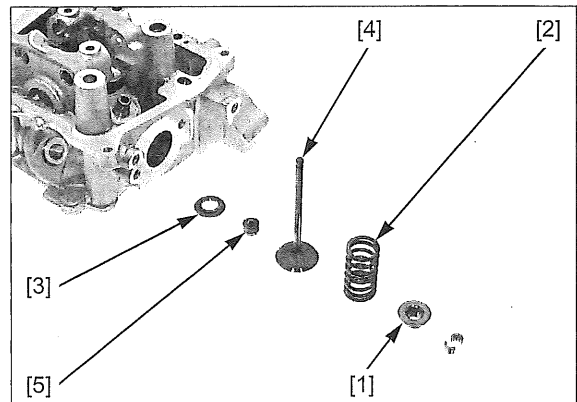

Avoid damaging the cylinder mating surface and valve seat surfaces. Remove the carbon deposits from the combustion chamber [1] and clean off the cylinder head gasket surface.

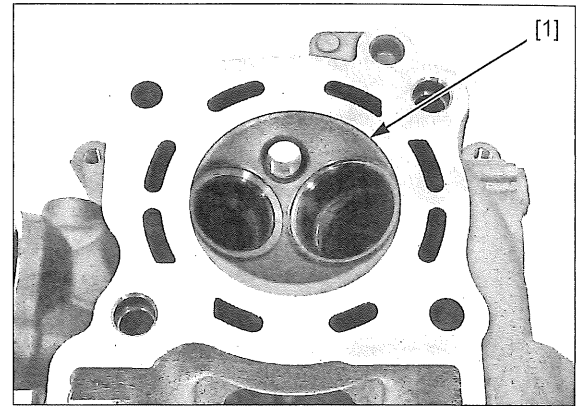

### INSPECTION

#### CYLINDER HEAD

Check the spark plug hole and valve areas for cracks. Check the cylinder head for warpage with a straight edge and a feeler gauge.

**SERVICE LIMIT: 0.05 mm (0.002 in)**

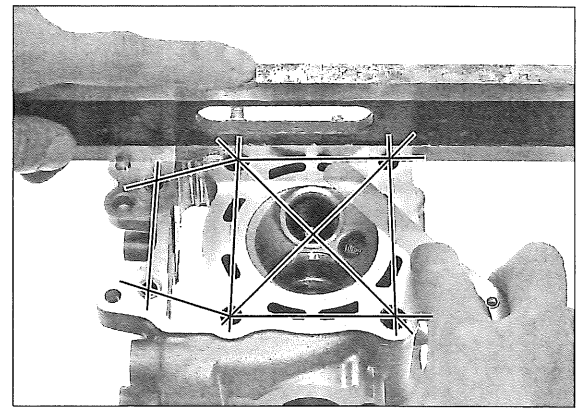

#### VALVE SPRING

Measure the free length of the valve springs.

**STANDARD: IN/EX: 36.94 mm (1.454 in)**

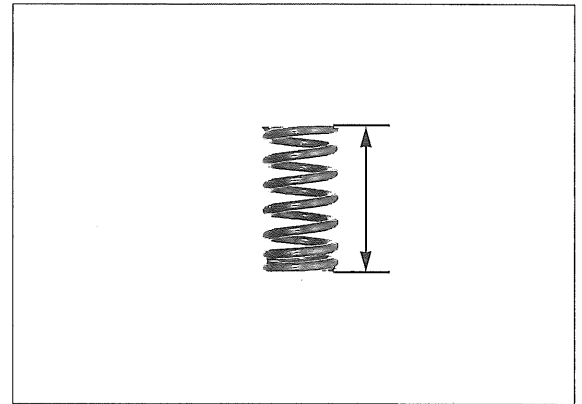

#### VALVE/VALVE GUIDE

Check that the valve moves smoothly in the guide. Check each valve for bends, burns, scratches, or abnormal wear.

Measure each valve stem O.D. and record it.

**SERVICE LIMITS: IN/EX: 4.90 mm (0.193 in)**

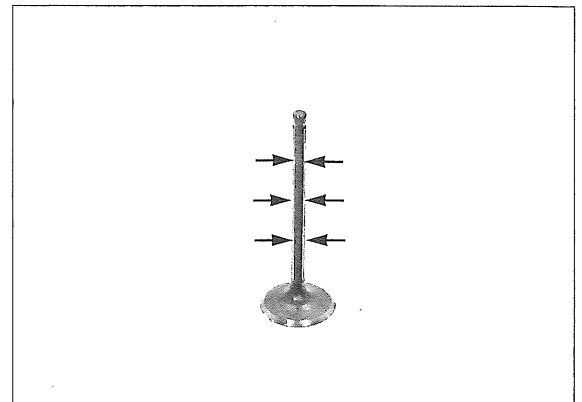

## CYLINDER HEAD/VALVES

*Always rotate the reamer clockwise when inserting, removing and reaming.*

Ream the valve guide to remove any carbon build up before measuring the guide. Insert the reamer [1] from the combustion chamber side of the cylinder head and always rotate the reamer clockwise.

### TOOL:

[1] Valve guide reamer, 5.0 mm 07984-MA60001 or 07984-MA6000D (U.S.A. only)

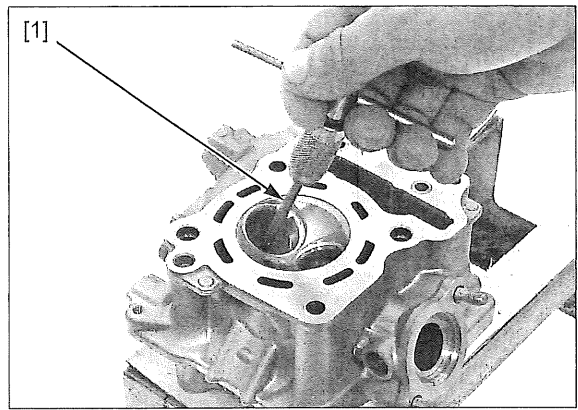

*Inspect and reface the valve seats whenever the valve guides are replaced (page 10-17).*

Measure each valve guide I.D. and record it.

**SERVICE LIMITS: IN/EX: 5.03 mm (0.198 in)**

Subtract each valve stem O.D. from the corresponding guide I.D. to obtain the stem-to-guide clearance.

**SERVICE LIMITS: IN: 0.08 mm (0.003 in)  
EX: 0.10 mm (0.004 in)**

If the stem-to-guide clearance exceeds the service limit, determine if a new guide with standard dimensions would bring the clearance within tolerance.

If so, replace any guides as necessary and ream to fit (page 10-16).

If the stem-to-guide clearance exceeds the service limit with a new guide, also replace the valve.

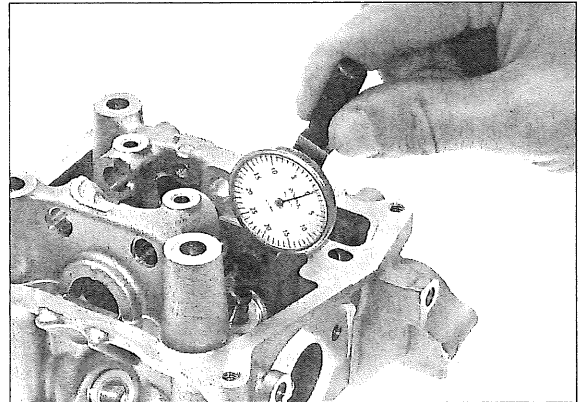

### CAM CHAIN GUIDE

Check the sliding area of the cam chain guide [1] for excessive wear or damage.

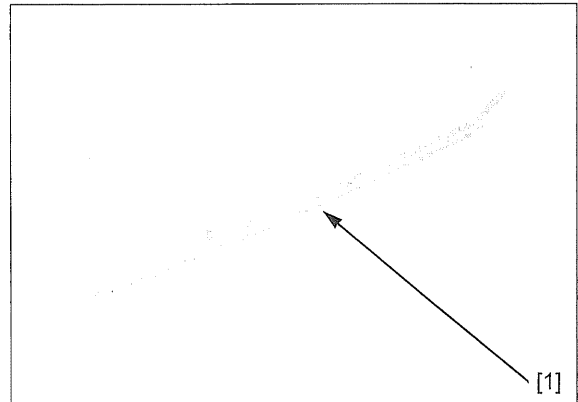

**VALVE GUIDE REPLACEMENT**

Disassemble the cylinder head (page 10-14).

Chill new valve guides in a freezer for about 1 hour.

**NOTE:**

- Be sure to wear heavy gloves to avoid burns when handling the heated cylinder head.
- Using a torch to heat the cylinder head may cause warpage.
- Drive new guides [1] from the camshaft side while the cylinder head is still heated.

Heat the cylinder head to 130 – 140°C with a hot plate or oven. Do not heat the cylinder head beyond 150°C. Use temperature indicator sticks, available from welding supply stores, to be sure the cylinder head is heated to the proper temperature.

Support the cylinder head and drive the valve guides out of the cylinder head from the combustion chamber side.

**TOOL:**

[2] Valve guide driver, 5.0 mm 07942-MA60000

Take out new valve guides [1] from the freezer.

Drive new valve guides into the cylinder head to the specified height from the cylinder head.

**TOOL:**

[2] Valve guide adjusting driver 07743-0020000  
(Not available in U.S.A.)

**VALVE GUIDE PROJECTION:**

IN/EX: 11.05 – 11.35 mm (0.435 – 0.447 in)

Let the cylinder head cool to room temperature.

Ream new valve guides after installation.

**NOTE:**

- Take care not to tilt or lean the reamer [1] in the guide while reaming.
- Use cutting oil on the reamer during this operation.

Insert the reamer from the combustion chamber side of the cylinder head and always rotate the reamer clockwise.

**TOOL:**

[1] Valve guide reamer, 5.0 mm 07984-MA60001 or 07984-MA6000D  
(U.S.A. only)

Clean the cylinder head thoroughly to remove any metal particles after reaming and reface the valve seat (page 10-18).

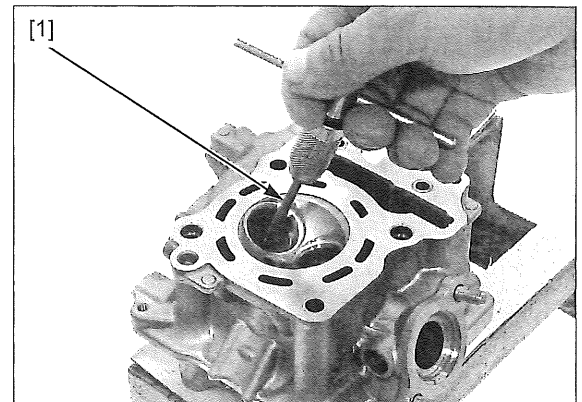
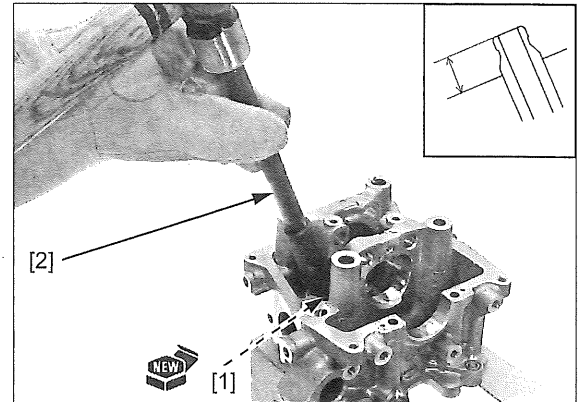
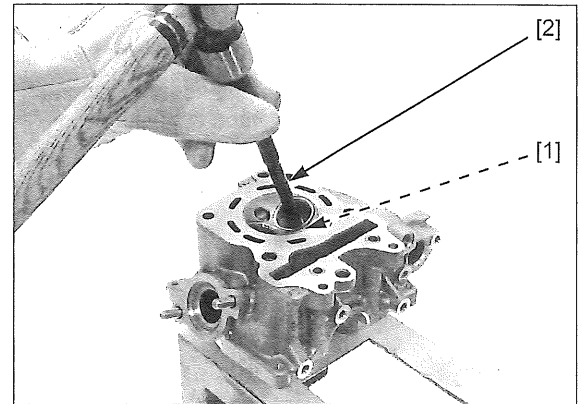

## CYLINDER HEAD/VALVES

### VALVE SEAT INSPECTION/REFACING

#### INSPECTION

Disassemble the cylinder head (page 10-14).

Clean the intake and exhaust valves thoroughly to remove carbon deposits.

Apply a light coat of Prussian Blue to the valve seats. Tap the valve against the valve seat several times using a hand-lapping tool, without rotating the valve to make a clear pattern.

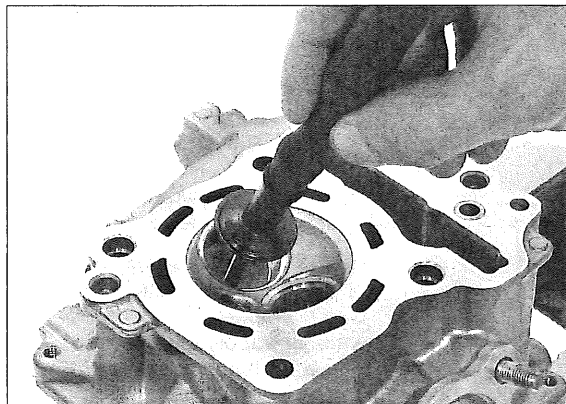

*The valves cannot be ground. If the valve face is burned, badly worn or if it contacts the seat unevenly, replace the valve.*

Remove the valve and inspect the valve seat face.

The valve seat contact should be within the specified width and even all around the circumference.

**STANDARD: 0.90 – 1.10 mm (0.035 – 0.043 in)**

**SERVICE LIMIT: 1.5 mm (0.06 in)**

If the valve seat width is not within specification, reface the valve seat.

Inspect the valve seat face for:

- Damaged face:
  - Replace the valve and reface the valve seat
- Uneven seat width:
  - Bent or collapsed valve stem; Replace the valve and reface the valve seat
- Contact area too low or too high:
  - Reface the valve seat

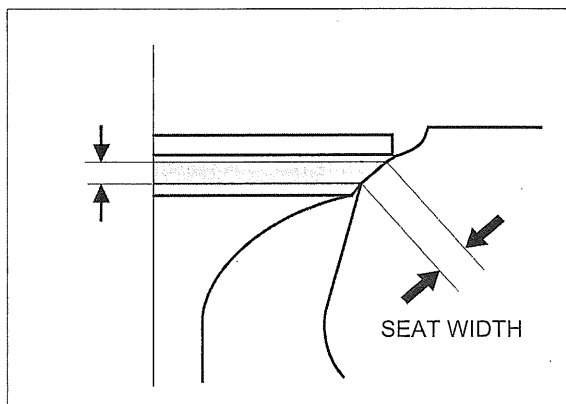



**REFACING**

**NOTE:**

- Follow the refacer manufacturer's operating instructions.
- Be careful not to grind the seat more than necessary.

If the contact area is too high on the valve, the seat must be lowered using a 32° flat cutter.

If the contact area is too low on the valve, the seat must be raised using a 60° interior cutter.

Refinish the seat to specifications, using a 45° finish cutter.

*Reface the seat with a 45° cutter whenever a valve guide is replaced.*

Use a 45° seat cutter, remove any roughness or irregularities from the seat.

**TOOLS:**

- Seat cutter, 29 mm (IN, 45°) 07780-0010300
  - Seat cutter, 27.5 mm (EX, 45°) 07780-0010200
  - Cutter holder, 5.0 mm 07781-0010400
- or equivalent commercially available in U.S.A.

Use a 32° flat cutter, remove the top 1/4 of the existing valve seat material.

**TOOLS:**

- Flat cutter, 30 mm (IN, 32°) 07780-0012200
  - Flat cutter, 27 mm (EX, 32°) 07780-0013300
  - Cutter holder, 5.0 mm 07781-0010400
- or equivalent commercially available in U.S.A.

Use a 60° interior cutter, remove the bottom 1/4 of the existing valve seat material.

**TOOLS:**

- Interior cutter, 30 mm (IN, 60°) 07780-0014000
  - Interior cutter, 24 mm (EX, 60°) 070PH-Z0D0100
  - Cutter holder, 5.0 mm 07781-0010400
- or equivalent commercially available in U.S.A.

Using a 45° seat cutter, cut the seat to the proper width.

**VALVE SEAT WIDTH:**

0.90 – 1.10 mm (0.035 – 0.043 in)

Make sure that all pitting and irregularities are removed.

**NOTE:**

- Excessive lapping pressure may deform or damage the seat.
- Change the angle of lapping tool [1] frequently to prevent uneven seat wear.
- Do not allow lapping compound to enter the guides.

After cutting the seat, apply lapping compound to the valve face, and lap the valve using light pressure.

After lapping, wash any residual compound off the cylinder head and valve and recheck the seat contact.

Assemble the cylinder head (page 10-20).

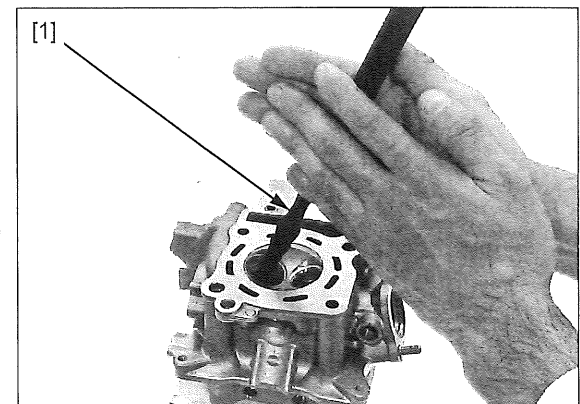
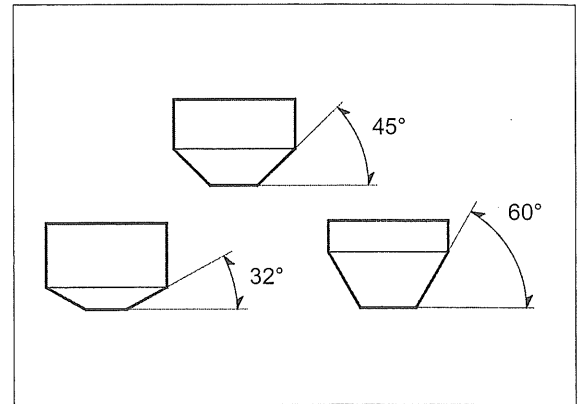

# CYLINDER HEAD/VALVES

## ASSEMBLY

### \* ROCKER ARMS

: Roller surface

: Needle bearing sliding surface

\* EXHAUST  
ROCKER ARM

\* INTAKE  
ROCKER ARM

ROCKER ARM SHAFT STOPPER BOLT  
5 N·m (0.51 kgf·m, 3.7 lbf·ft)

COTTERS

SPRING RETAINER

VALVE SPRING

VALVE STEM SEAL

SPRING SEAT

VALVE GUIDE

EXHAUST VALVE

WATER PUMP HOLDER BOLTS  
10 N·m (1.0 kgf·m, 7 lbf·ft)

INTAKE VALVE

CAMSHAFT STOPPER BOLT  
10 N·m (1.0 kgf·m, 7 lbf·ft)

CAMSHAFT

: Bearing area

: Cam lobes and decompressor area

INTAKE ROCKER  
ARM SHAFT

Blow through the oil passage in the cylinder head with compressed air.

Apply engine oil to the inner surface of new valve stem seals [1].

Install the valve spring seats [2] and new valve stem seals.

Apply molybdenum oil solution to the valve stem sliding surface and stem end.

Insert the valves [3] into the valve guides while turning them slowly to avoid damage to the valve stem seals.

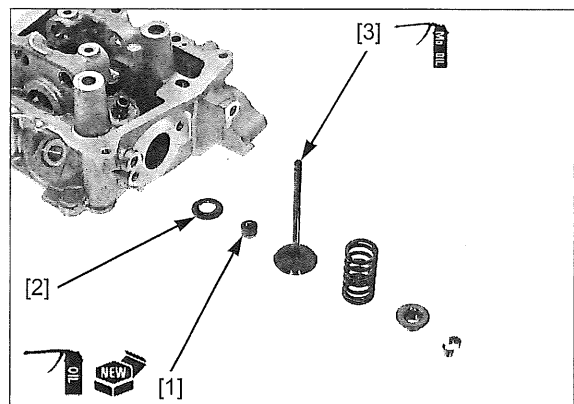

Install the valve spring [1] with the tightly wound coil facing the combustion chamber.

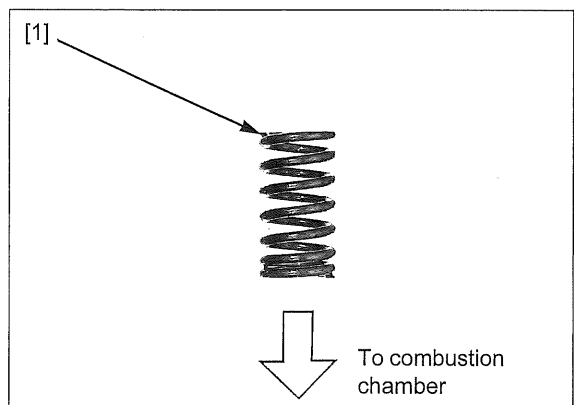

Install the valve spring retainer [1].

*To prevent loss of tension, do not compress the valve spring more than necessary to install the cotters.*

Install the valve cotters [2] using the special tool.

**TOOLS:**

- [3] Valve spring compressor 07757-0010000
- [4] Valve spring compressor attachment 07959-KM30101

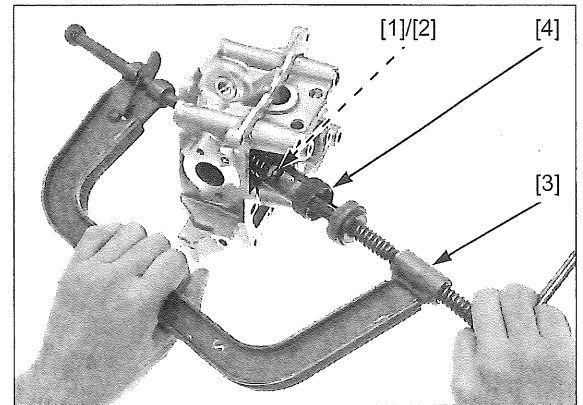

*Support the cylinder head above the work bench surface to prevent valve damage.*

Place a suitable tool [1] onto the valve stem [2].

Tap the tool gently to seat the cotters [3] firmly using a hammer.

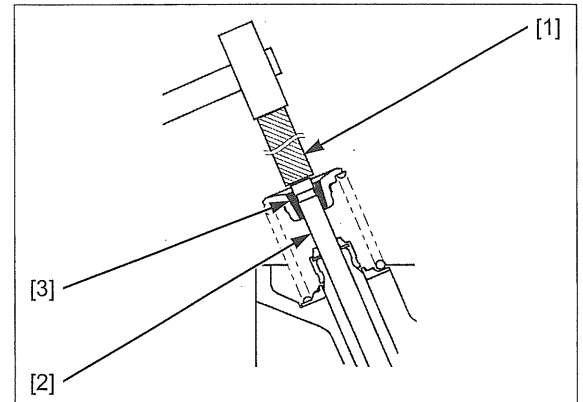

Apply liquid sealant (Three Bond 1207B or 1215 or LOCTITE 5060S or 5020 or equivalent) to the mating surface of the cylinder head and water pump holder [1] as shown.

Install the water pump holder while aligning its pins with the holes on the cylinder head.

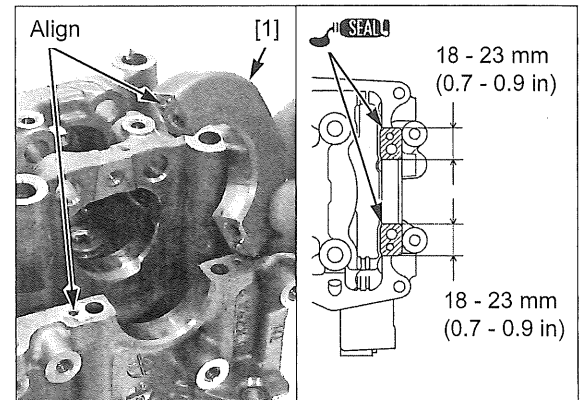

Install and tighten the water pump holder bolts [1] to the specified torque.

**TORQUE: 10 N·m (1.0 kgf·m, 7 lbf·ft)**

After tightening the bolts, wipe off the excess sealant from the water pump joint area and cylinder head cover rubber seal mating surfaces.

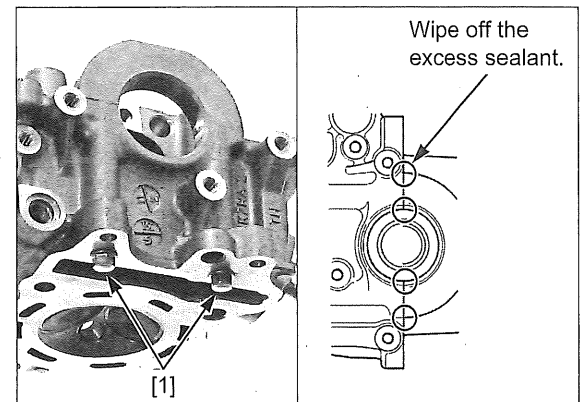

## CYLINDER HEAD/VALVES

### INSTALLATION

Install the cam chain guide [1] while aligning its pins with the grooves on the cylinder and its end with the groove on the right crankcase.

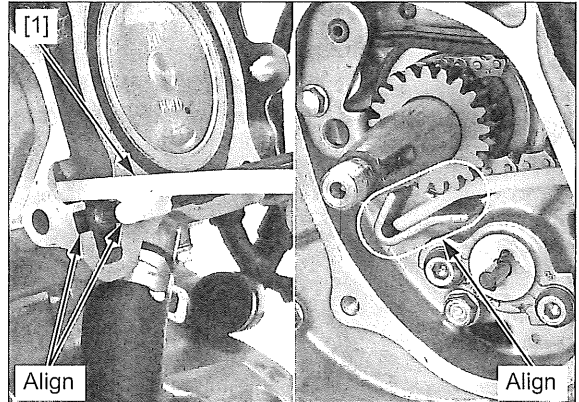

Clean the cylinder and cylinder head mating surface.

*Do not reuse the old gasket.* Install the dowel pins [1] and a new gasket [2] onto the cylinder.

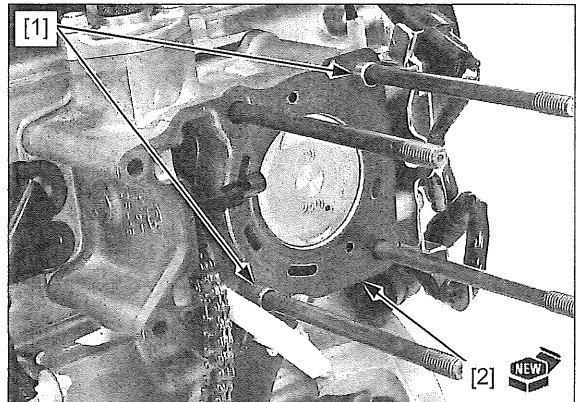

Route the cam chain [1] through the cylinder head [2] and install the cylinder head onto the cylinder.

Apply engine oil to the seating surface and threads of the cylinder head nuts [3], whole surface of the washers [4] and cylinder stud bolt upper threads [5]. Install the cylinder head nuts and washers, then tighten them in a crisscross pattern to the specified torque.

**TORQUE: 27 N·m (2.8 kgf·m, 20 lbf·ft)**

Install and tighten the cylinder head bolts [6].

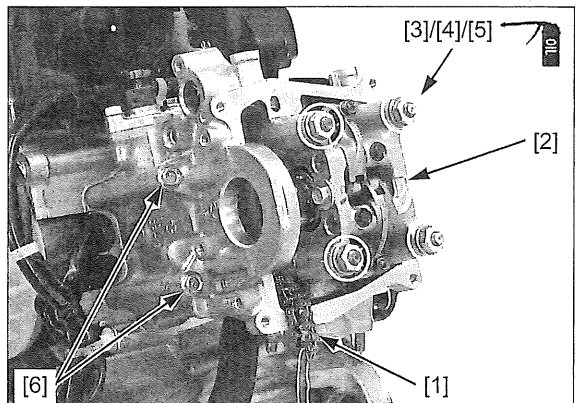

Install the wire guides [1] and tighten the bolts [2].

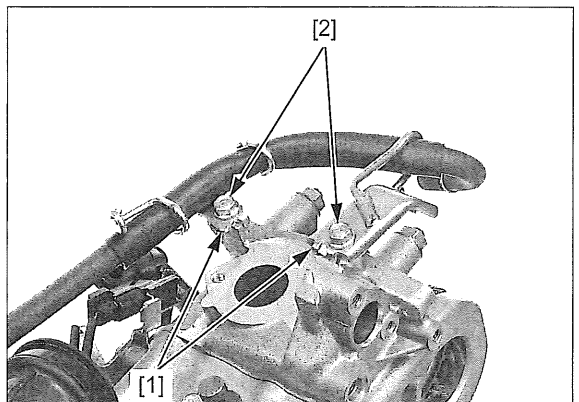

*Do not apply engine oil to this O-ring.*

Install a new O-ring [1] to the water joint [2].  
 Install the water joint and two bolts [3], then tighten them.

Install the following:

- ECT sensor (page 4-52)
- O<sub>2</sub> sensor (page 4-54)
- Spark plug (page 3-9)
- Intake pipe (page 7-25)
- Exhaust pipe/muffler (page 2-28)
- Camshaft (page 10-10)
- Engine (page 16-7)

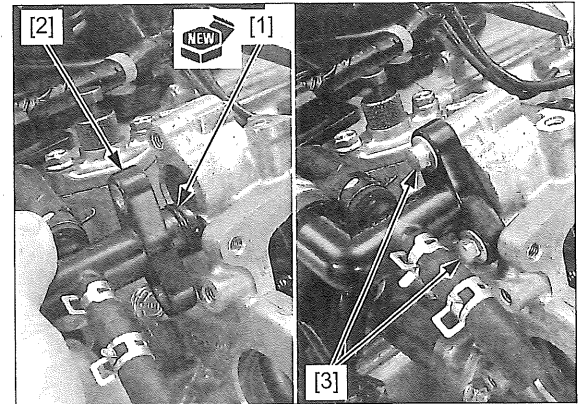

## CAM CHAIN TENSIONER LIFTER

### REMOVAL

Remove the throttle body (page 7-15).

Remove the tensioner screw [1] and O-ring [2].

Install the special tool [3] into the tensioner body and turn the tool clockwise until it stops turning. Hold the tensioner lifter by pushing the tool while aligning the tabs of the tool with the grooves of the tensioner lifter.

#### TOOL:

[3] Tensioner holder 070MG-0010100 or  
07AMG-001A100  
(U.S.A. only)

Remove the bolts [4] and cam chain tensioner lifter [5].  
 Remove the gasket [6] from the tensioner lifter.

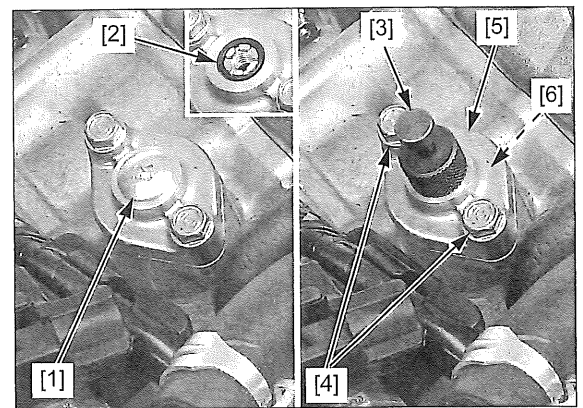

### INSPECTION

Remove the cam chain tensioner lifter [1] (page 10-23).

Check the cam chain tensioner lifter operation:

- The tensioner shaft [2] should not go into the body when it is pushed.
- When it is turned clockwise with the tensioner holder [3], the tensioner shaft should be pulled into the body. The shaft should protrude from the body as soon as the tensioner holder is released.

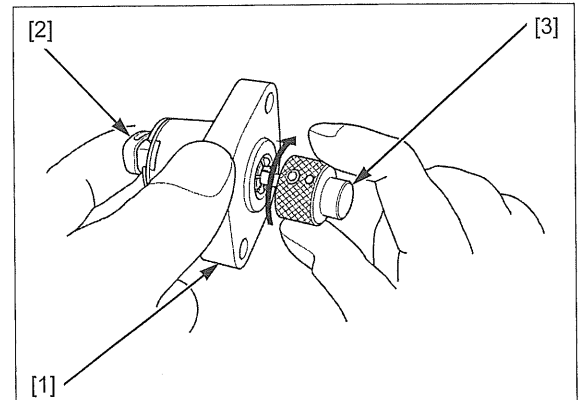

### INSTALLATION

Install a new gasket [1] to the cam chain tensioner lifter [2].

Install the tensioner stopper [3] and turn the tensioner shaft clockwise with it to retract the tensioner fully.

Install the tensioner lifter and two bolts [4], then tighten them.

Remove the tensioner stopper.

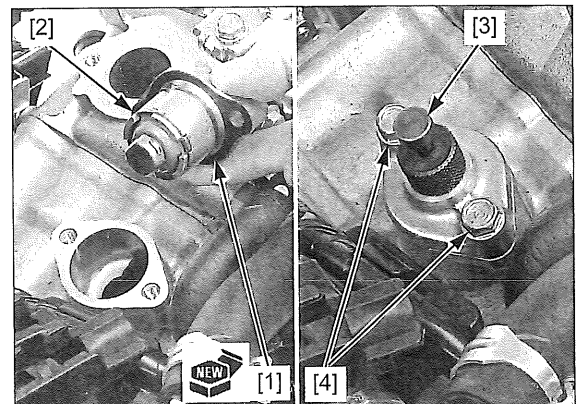

## CYLINDER HEAD/VALVES

Apply engine oil to a new O-ring [1].

Install a new O-ring to the cam chain tensioner lifter.  
Install and tighten the screw [2] to the specified torque.

**TORQUE: 4 N·m (0.41 kgf·m, 3.0 lbf·ft)**

Install the throttle body (page 7-19).

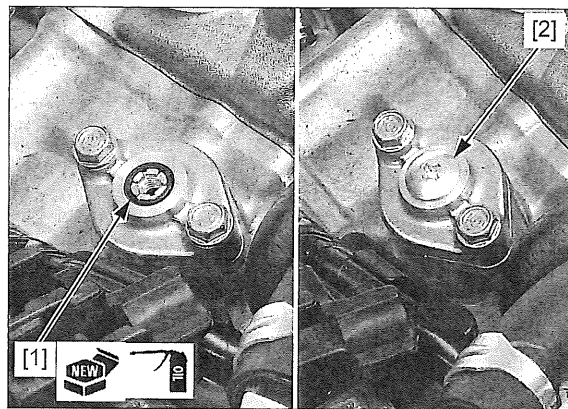

# 11. CYLINDER/PISTON

---

COMPONENT LOCATION .....	11-2	CYLINDER .....	11-5
SERVICE INFORMATION .....	11-3	PISTON .....	11-7
TROUBLESHOOTING .....	11-4		

COMPONENT LOCATION

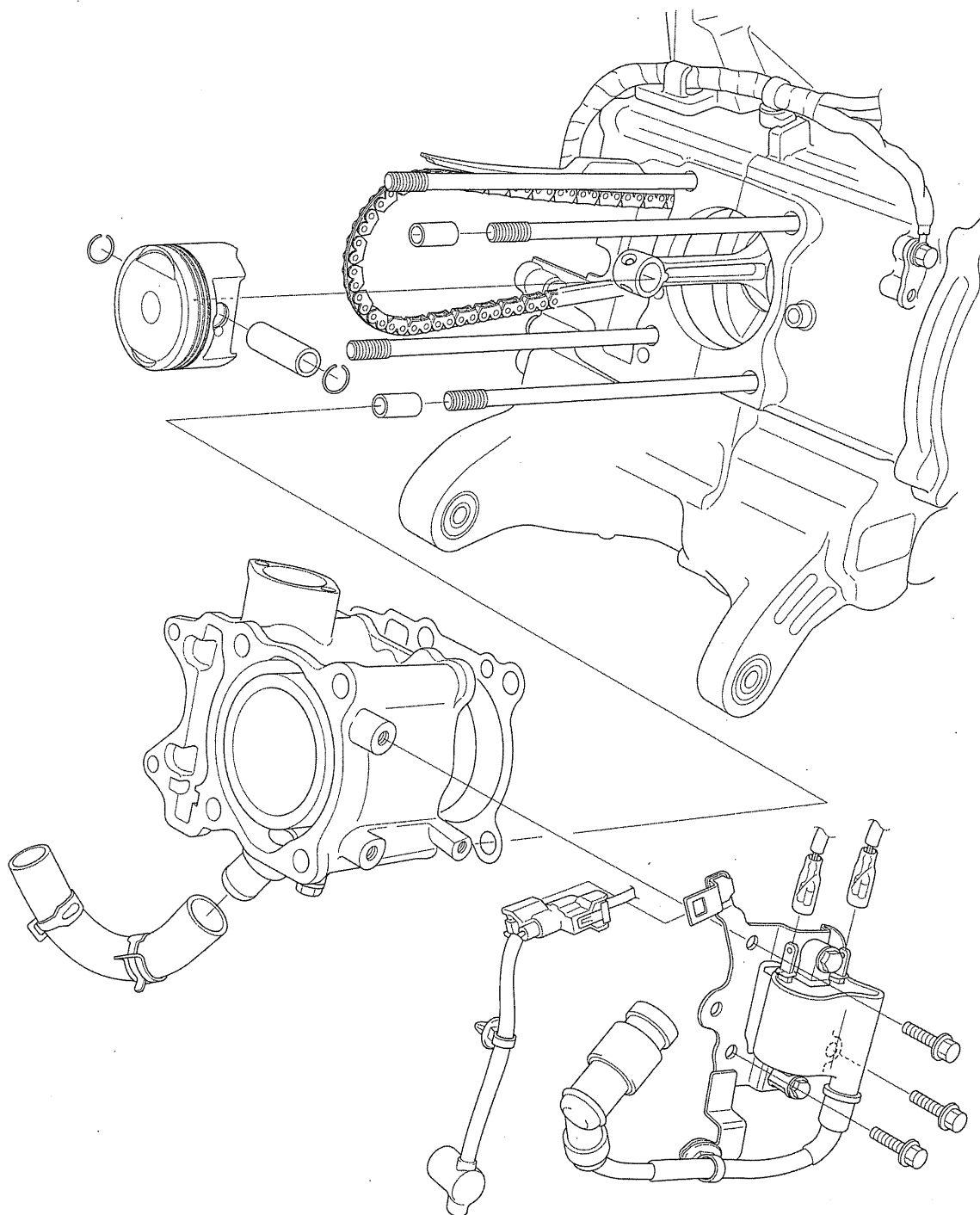



## SERVICE INFORMATION

### GENERAL

- This section covers maintenance of the cylinder and piston. These services require engine removal.
- Be careful not to damage mating surfaces when removing the cylinder. Do not tap the cylinder too hard during removal.
- Take care not to damage the cylinder wall and piston.
- Clean all disassembled parts with clean solvent and dry them using compressed air before inspection.
- When removing the piston, clean carbon and sludge from the top of the cylinder.

### SPECIFICATIONS

Unit: mm (in)

ITEM		STANDARD	SERVICE LIMIT	
Cylinder	I.D.	58.000 – 58.010 (2.2835 – 2.2839)	–	
	Out-of-round	–	0.05 (0.002)	
	Taper	–	0.05 (0.002)	
	Warpage	–	0.05 (0.002)	
Piston, piston rings, piston pin	Piston O.D.	57.970 – 57.990 (2.2822 – 2.2831)	–	
	Piston O.D. measurement point	6.5 (0.26) from bottom of skirt	–	
	Piston pin bore I.D.	14.002 – 14.008 (0.5513 – 0.5515)	14.04 (0.553)	
	Piston pin O.D.	13.994 – 14.000 (0.5509 – 0.5512)	13.96 (0.550)	
	Piston-to-piston pin clearance	0.002 – 0.014 (0.0001 – 0.0006)	0.02 (0.001)	
	Piston ring-to-ring groove clearance	Top	0.015 – 0.055 (0.0006 – 0.0022)	0.08 (0.003)
		Second	0.015 – 0.055 (0.0006 – 0.0022)	0.08 (0.003)
	Piston ring end gap	Top	0.10 – 0.25 (0.004 – 0.0010)	0.45 (0.018)
		Second	0.38 – 0.52 (0.015 – 0.0020)	–
Oil (side rail)		0.20 – 0.70 (0.008 – 0.028)	–	
Cylinder-to-piston clearance		0.01 – 0.04 (0.0004 – 0.0016)	0.09 (0.004)	
Connecting rod small end I.D.		14.010 – 14.028 (0.5516 – 0.5523)	14.06 (0.554)	
Connecting rod-to-piston pin clearance		0.010 – 0.034 (0.0004 – 0.0013)	0.05 (0.002)	

### TORQUE VALUE

ITEM	Q'TY	THREAD DIA. (mm)	TORQUE N·m (kgf·m, lbf·ft)	REMARKS
Cylinder stud bolt	4	8	–	See page 11-6

## CYLINDER/PISTON

---

### TROUBLESHOOTING

#### **Compression too low, hard starting or poor performance at low speed**

- Worn, stuck or broken piston ring
- Worn or damaged cylinder and piston
- Bent connecting rod
- Cylinder head/valve problem (page 10-15)

#### **Compression too high, overheating or knocking**

- Excessive carbon build-up on piston head or on combustion chamber

#### **Excessive smoke**

- Worn cylinder, piston or piston ring
- Improper installation of piston rings
- Scored or scratched piston or cylinder wall
- Cylinder head/valve problem (page 10-15)

#### **Abnormal noise**

- Worn piston pin or piston pin hole
- Worn connecting rod small end
- Worn cylinder, piston or piston rings

#### **Piston ring sticking/scuffing, bearing damage**

- Clogged oil gallery or oil strainer screen
- Internal oil leak
- Not using recommended engine oil

## CYLINDER

### REMOVAL

Remove the cylinder head (page 10-13).

Release the O<sub>2</sub> sensor 1P (Black) connector [1] from the ignition coil stay [2].

Disconnect the ignition coil wire connectors [3]

Remove the bolts [4] and ignition coil stay.

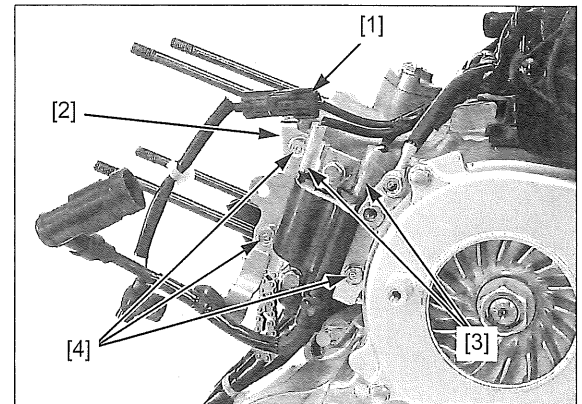

*Be careful not to damage the mating surface.*

Remove the cylinder [1].

- Attach a piece of wire to the cam chain [2] to prevent it from falling into the crankcase.

Disconnect the water hose [3] from the cylinder.

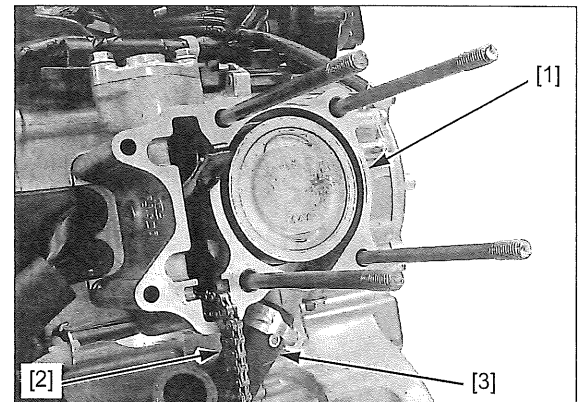

*Do not reuse the old gasket.*

Remove the gasket [1] and dowel pins [2].

Clean off any gasket material from the cylinder mating surface of the crankcase.

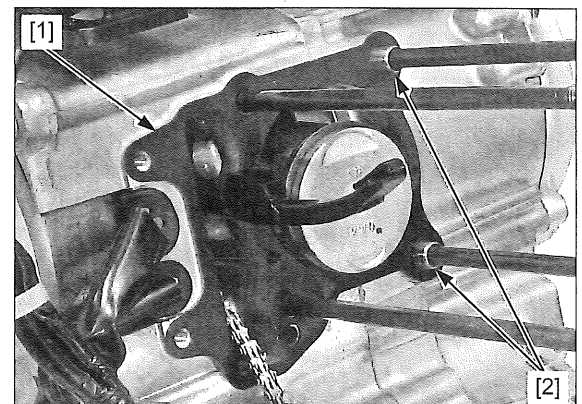

### INSPECTION

Check the cylinder for warpage with a straight edge and feeler gauge in the directions shown.

**SERVICE LIMIT: 0.05 mm (0.002 in)**

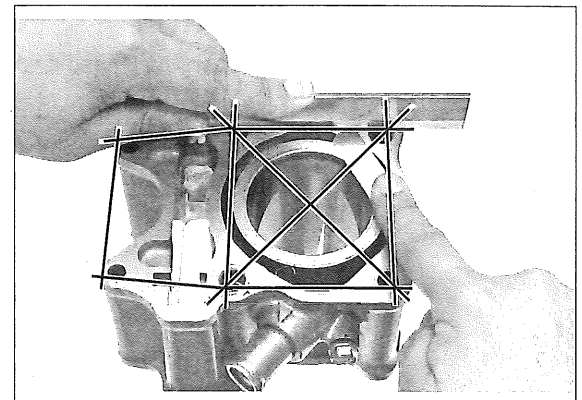

## CYLINDER/PISTON

Inspect the cylinder bore for wear or damage. Measure the cylinder I.D. in the X and Y axis at three levels. Take the maximum reading to determine the cylinder wear.

### STANDARD:

**58.000 – 58.010 mm (2.2835 – 2.2839 in)**

Calculate the taper and out-of-round at three levels in the X and Y axis. Take the maximum reading to determine both measurements.

**SERVICE LIMITS: Taper: 0.05 mm (0.002 in)**  
**Out-of-round: 0.05 mm (0.002 in)**

The cylinder must be rebored and an oversize piston/piston rings fitted if the service limits are exceeded.

The following oversize pistons/piston rings are available:

**0.25 mm (0.010 in)**  
**0.50 mm (0.020 in)**  
**0.75 mm (0.030 in)**  
**1.00 mm (0.039 in)**

The piston to cylinder clearance for the oversize piston must be: 0.01 – 0.04 mm (0.0004 – 0.0016 in).

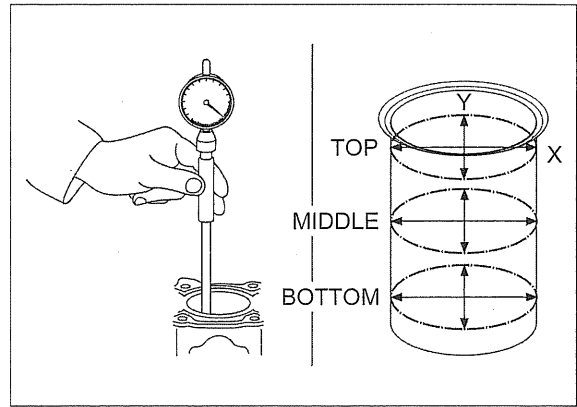

## STUD BOLT REPLACEMENT

Thread two nuts onto the stud and tighten them together, and use wrench on them to turn the stud bolt out.

*Install the stud bolts with their larger thread end O.D. [3] sides facing the crankcase.*

Install new stud bolts A [1] into the right crankcase. Install new stud bolts B [2] into the left crankcase. Tighten the stud bolts to the specified torque.

**TORQUE: 9 N·m (0.9 kgf·m, 6.6 lbf·ft)**

After cylinder stud bolt installation, check that the length from the bolt head to the crankcase surface is within specification.

**SPECIFIED STUD BOLT A: 179.0 – 180.0 mm (7.05 – 7.09 in)**  
**LENGTH:**

**STUD BOLT B: 179.0 – 180.0 mm (7.05 – 7.09 in)**

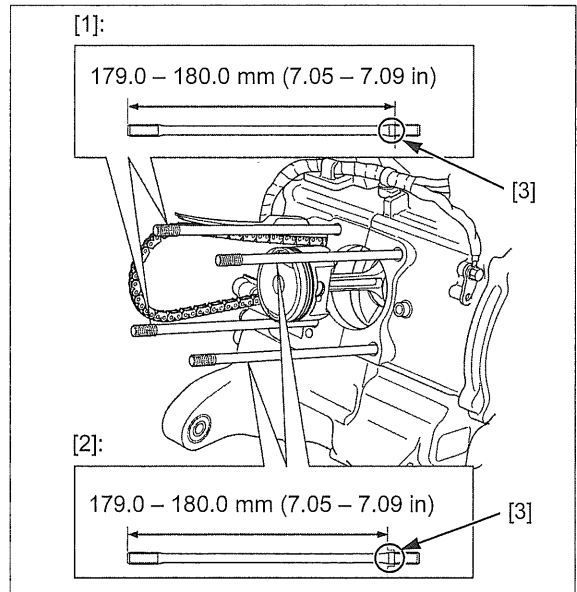

## INSTALLATION

*Do not reuse the old gasket.*

Install the dowel pins [1] and a new gasket [2].

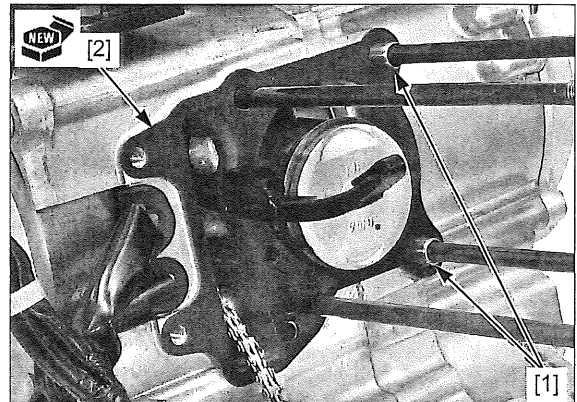

Apply engine oil to the cylinder [1] inner surface and piston sliding surface.  
Apply engine oil to the entire surface of the piston rings [2].

*Attach a piece of wire to the cam chain to prevent it from falling into the crankcase.*

Route the cam chain [3] through the cylinder.  
Install the cylinder over the piston while compressing the piston rings with your finger.

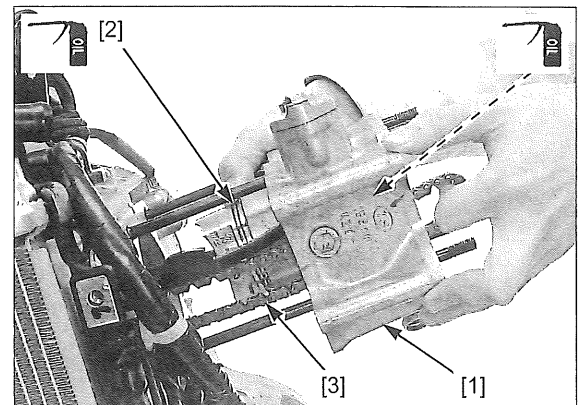

Install the ignition coil stay [1] and tighten the bolts [2].  
Connect the ignition coil wire connectors [3].  
Install the O<sub>2</sub> sensor 1P (Black) connector [4] to the ignition coil stay.  
Install the cylinder head (page 10-22).

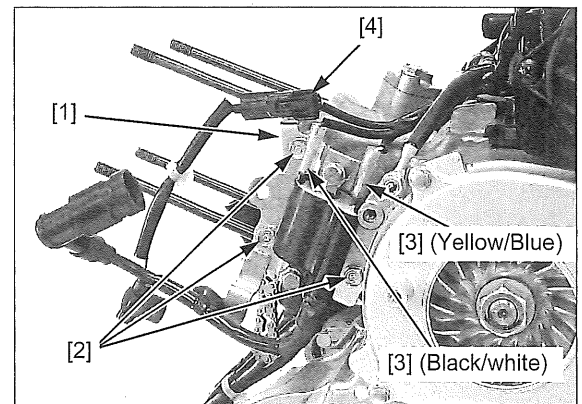

## PISTON

### REMOVAL

*Be careful not to let the piston pin clips fall into the opening of the crankcase.*

Remove the cylinder (page 11-5).  
Remove the piston pin clips [1] with pliers.  
Push the piston pin [2] out of the piston [3] and connecting rod, then remove the piston.

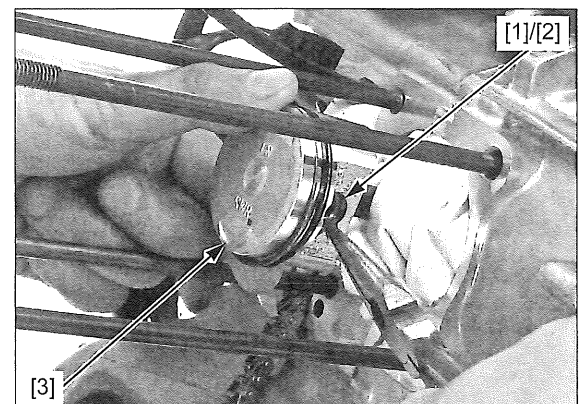

Spread each piston ring [1] and remove it by lifting up at a point opposite the gap.

*Never use a wire brush. It will damage the groove.*

Clean carbon deposits from the ring grooves with a ring that will be discarded.

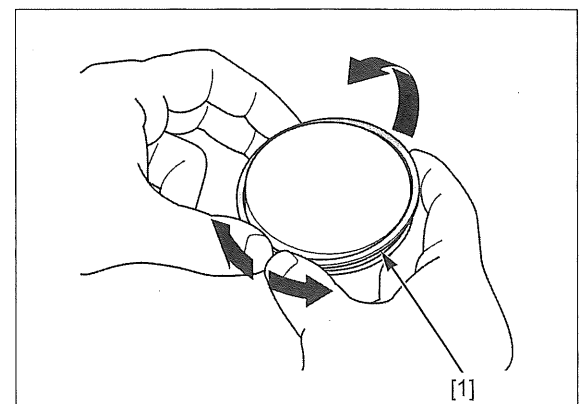

## CYLINDER/PISTON

### INSPECTION

Inspect the piston rings for movement by rotating the rings. The rings should be able to move in their grooves without catching.

Push the ring until the outer surface of the piston ring is nearly flush with the piston and measure the ring-to-groove clearance.

**SERVICE LIMITS: Top/Second: 0.08 mm (0.003 in)**

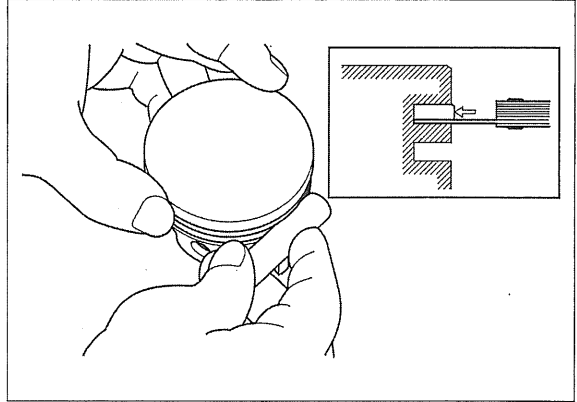

Insert each piston ring into the bottom of the cylinder squarely using the piston. Measure the ring end gap.

**STANDARD:**

**Top: 0.10 – 0.25 mm (0.004 – 0.0010 in)**

**Second: 0.38 – 0.52 mm (0.015 – 0.0020 in)**

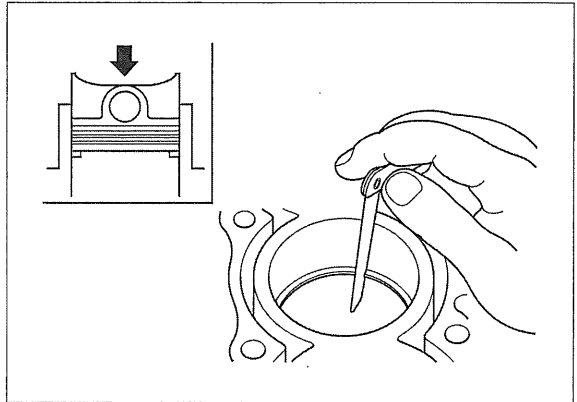

Check the piston outer surface for scratches or damage.

Measure the piston pin hole. Take the maximum reading to determine I.D.

**SERVICE LIMIT: 14.04 mm (0.553 in)**

Measure the piston pin O.D. at piston and connecting rod sliding areas.

**SERVICE LIMIT: 13.96 mm (0.550 in)**

Calculate the piston-to-piston pin clearance.

**SERVICE LIMIT: 0.02 mm (0.001 in)**

Measure the piston O.D. at the point 6.5 mm (0.26 in) from the bottom and 90° to the piston pin hole.

**STANDARD: 57.970 – 57.990 mm (2.2822 – 2.2831 in)**

Calculate the cylinder-to-piston clearance (cylinder I.D.: page 11-6).

**SERVICE LIMIT: 0.09 mm (0.004 in)**

Measure the connecting rod small end I.D.

**SERVICE LIMIT: 14.06 mm (0.554)**

Calculate the connecting rod-to-piston pin clearance.

**SERVICE LIMIT: 0.05 mm (0.002 in)**

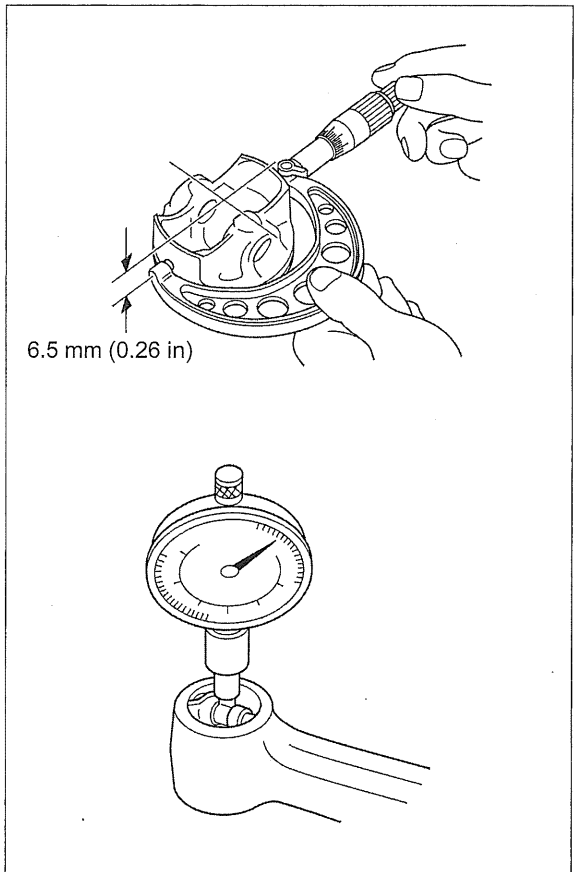

**INSTALLATION**

Apply engine oil to the rings and ring grooves [1].

Carefully install the piston rings into the piston ring grooves with the markings [2] facing up.

**NOTE:**

- Do not confuse the top ring [3] and second ring [4].
- To install the oil ring, install the spacer [5] first, then install the side rails [6].

Stagger the piston ring end gaps 120 ° apart from each other.

Stagger the side rail end gaps as shown.

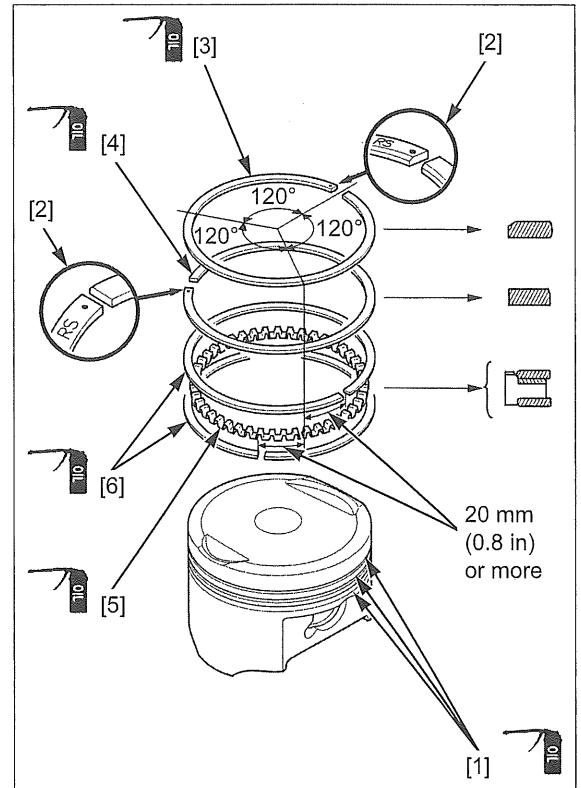

Apply engine oil to the connecting rod [1] small end inner surface.

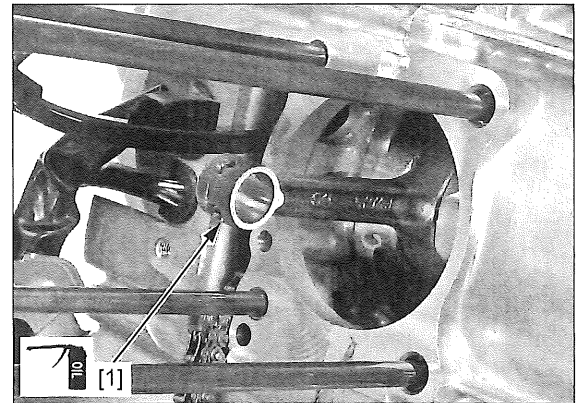

Apply engine oil to the piston pin [1] outer surface and piston pin hole inner surface.

Install the piston [2] with the "IN" mark [3] facing the intake side.

Install the piston pin.

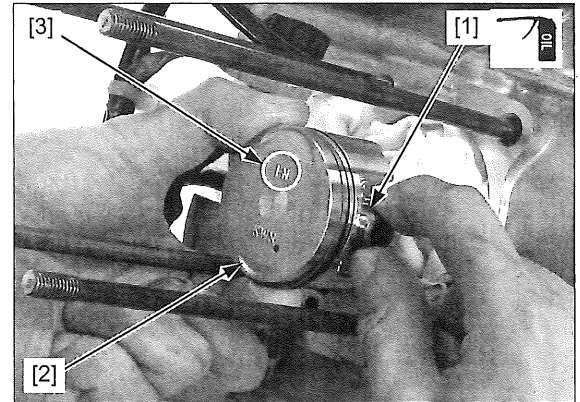

## CYLINDER/PISTON

*Be careful not to let the piston pin clips fall into the opening of the crankcase.*

Install the new pin clips [1].

**NOTE:**

- Make sure the piston pin clips are seated securely.
- Do not align the piston pin clip end gap with the piston cut-out [2].

Install the cylinder (page 11-6).

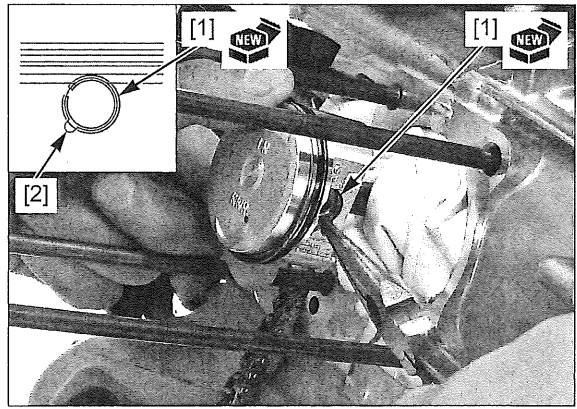



# 12. DRIVE PULLEY/DRIVEN PULLEY/CLUTCH

---

COMPONENT LOCATION .....	12-2	DRIVE BELT .....	12-8
SERVICE INFORMATION .....	12-3	DRIVE PULLEY .....	12-9
TROUBLESHOOTING .....	12-5	CLUTCH/DRIVEN PULLEY .....	12-12
LEFT CRANKCASE COVER .....	12-6		

# DRIVE PULLEY/DRIVEN PULLEY/CLUTCH

## COMPONENT LOCATION

59 N·m (6.0 kgf·m, 44 lbf·ft)

49 N·m (5.0 kgf·m, 36 lbf·ft)

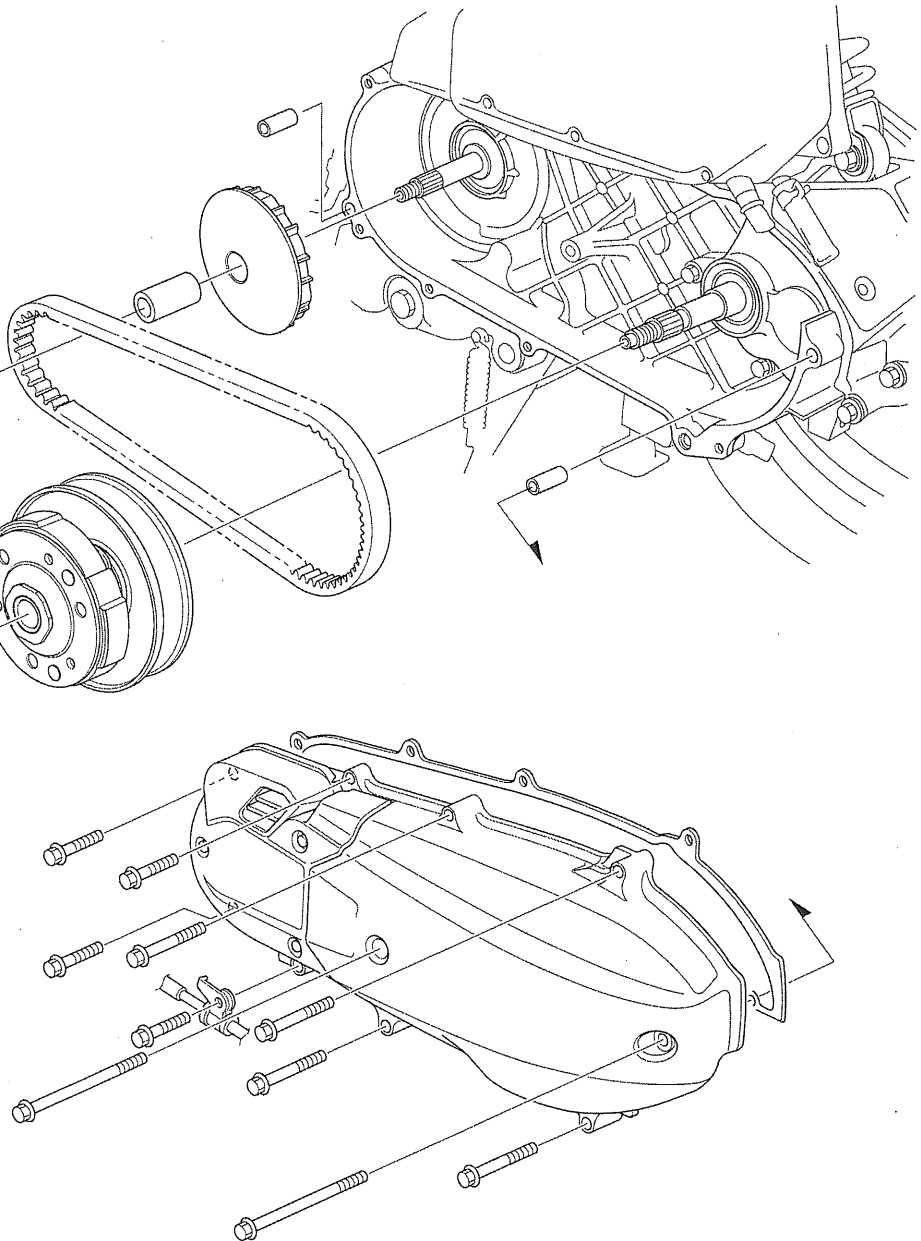

## SERVICE INFORMATION

### GENERAL

- This section covers maintenance of the drive pulley, driven pulley and clutch.
- These services can be done with the engine installed in the frame.
- Avoid getting grease and oil on the drive belt and drive/driven pulley faces in order to prevent belt slippage.
- Do not apply grease to the weight rollers.

### SPECIFICATIONS

Unit: mm (in)



	ITEM	STANDARD	SERVICE LIMIT
Drive belt width	'13 model	22.0 (0.87)	21.0 (0.83)
	After '13 model	22.6 (0.89)	21.6 (0.85)
Movable drive face	Bushing I.D.	23.989 – 24.052 (0.9444 – 0.9469)	24.08 (0.948)
	Boss O.D.	23.960 – 23.974 (0.9433 – 0.9439)	23.93 (0.942)
	Weight roller O.D.	19.92 – 20.08 (0.784 – 0.791)	19.5 (0.77)
Clutch	Lining thickness	–	2.0 (0.08)
	Clutch outer I.D.	125.0 – 125.2 (4.92 – 4.93)	125.5 (4.94)
Driven pulley	Face spring free length	151.1 (5.95)	146.6 (5.77)
	Driven face O.D.	33.965 – 33.985 (1.3372 – 1.3380)	33.94 (1.336)
	Movable driven face I.D.	34.000 – 34.025 (1.3386 – 1.3396)	34.06 (1.341)

### TORQUE VALUES



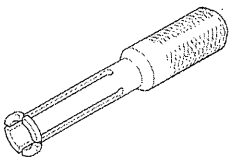
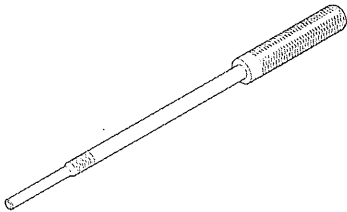
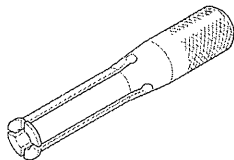
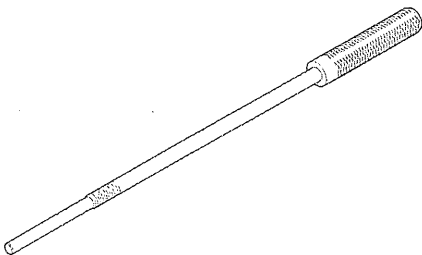
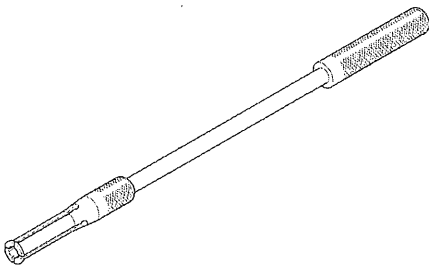
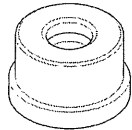

ITEM	Q'TY	THREAD DIA. (mm)	TORQUE N·m (kgf·m, lbf·ft)	REMARKS
Drive pulley face nut	1	14	59 (6.0, 44)	Apply oil to the threads and seating surface.
Clutch/driven pulley nut	1	28	54 (5.5, 40)	
Clutch outer nut	1	12	49 (5.0, 36)	

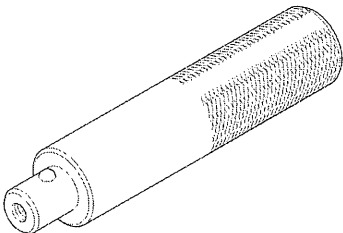
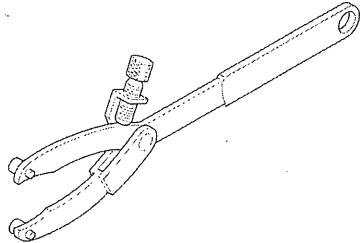
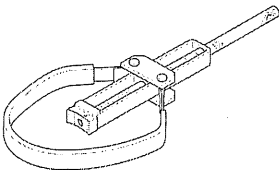
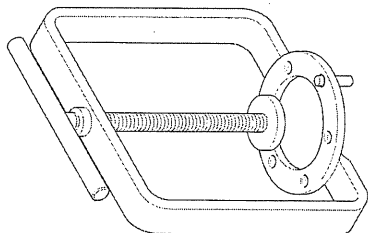
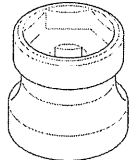
# DRIVE PULLEY/DRIVEN PULLEY/CLUTCH

## TOOLS

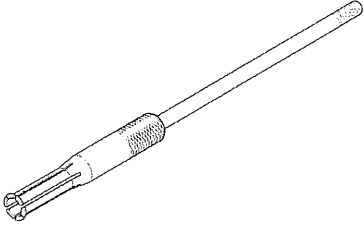
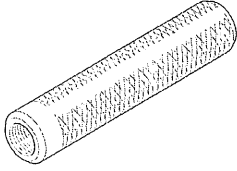
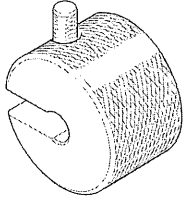
<p>Bearing remover head, 10 mm 07936-GE00200</p>  <p>(Not available in U.S.A.)</p>	<p>Bearing remover shaft, 10 mm 07936-GE00100</p>  <p>or 07936-GE0A000 (U.S.A. only)</p>	<p>Bearing remover head, 15 mm 07936-KC10200</p>  <p>(Not available in U.S.A.)</p>
<p>Bearing remover shaft, 15 mm 07936-KC10100</p>  <p>(Not available in U.S.A.)</p>	<p>Bearing remover, 15 mm 07936-KC10500 (U.S.A. only)</p> 	<p>Attachment, 32 x 35 mm 07746-0010100</p> 
<p>Pilot, 10 mm 07746-0040100</p> 	<p>Driver 07749-0010000</p> 	<p>Clutch center holder 07725-0030000</p> 
<p>Flywheel holder 07725-0040001</p> 	<p>Clutch spring compressor 07LME-GZ40201</p>  <p>or 07960-KM1000B (U.S.A. only)</p>	<p>Socket wrench, 39 x 41 mm 07GMA-KS40100</p>  <p>or equivalent commercially available in U.S.A.</p>

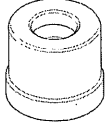
## DRIVE PULLEY/DRIVEN PULLEY/CLUTCH

<p>Bearing remover, 20 mm 07936-3710600</p> 	<p>Remover handle 07936-3710100</p> 	<p>Remover weight 07741-0010201</p>  <p>or 07936-371020A (U.S.A. only)</p>
<p>Pilot, 28 mm 07746-0041100</p> 	<p>Attachment, 28 x 30 mm 07946-1870100</p> 	<p>Pilot, 20 mm 07746-0040500</p> 

## TROUBLESHOOTING

### Engine starts but scooter won't move

- Worn drive belt
- Damaged ramp plate
- Worn or damaged clutch shoes and/or clutch outer
- Broken driven face spring

### Engine stalls or scooter creeps

- Broken clutch shoe spring

### Poor performance at high speed or lack of power

- Worn drive belt
- Weak driven face spring
- Worn weight rollers
- Contaminated pulley faces

**LEFT CRANKCASE COVER**

**REMOVAL**

Remove the left side cover (page 2-8).

Remove the bolts [1], rear brake cable clamp [2] and left crankcase cover [3].

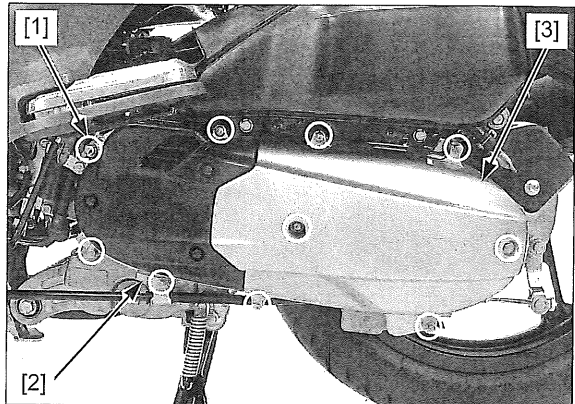

Remove the dowel pins [1] and gasket [2] from the left crankcase.

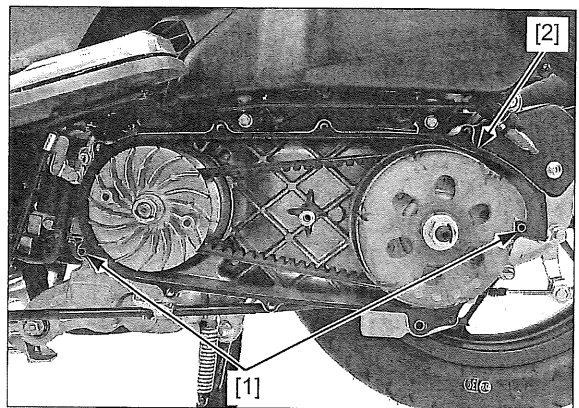

**BEARING INSPECTION/  
REPLACEMENT**

**INSPECTION**

Turn the inner race of the bearing with your finger. The bearing should turn smoothly and quietly. Also check that the bearing outer race fits tightly in the left crankcase cover.

Replace the bearing if the inner race does not turn smoothly, quietly, or if the outer race fits loosely in the left crankcase cover.

**REPLACEMENT**

Remove the snap ring [1] from the left crankcase cover groove.

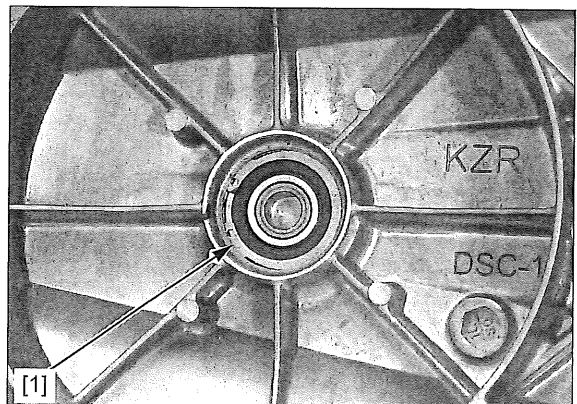

## DRIVE PULLEY/DRIVEN PULLEY/CLUTCH

Remove the drive shaft bearing [1]/bushing [2] using the special tools.

**TOOLS:**

[3] Bearing remover head, 10 mm	07936-GE00200
[4] Bearing remover shaft, 10 mm	07936-GE00100
[5] Remover weight	07741-0010201

**U.S.A. TOOLS:**

Bearing remover, 10 mm	07936-GE0A000
Remover handle	07936-3710100
Remover weight	07936-371020A

– If the bearing remains in the left crankcase cover, remove it using the following tools:

**TOOLS:**

[6] Bearing remover head, 15 mm	07936-KC10200
[7] Bearing remover shaft, 15 mm	07936-KC10100
[5] Remover weight	07741-0010201

**U.S.A. TOOLS:**

Bearing remover, 15 mm	07936-KC10500
Remover weight	07936-371020A

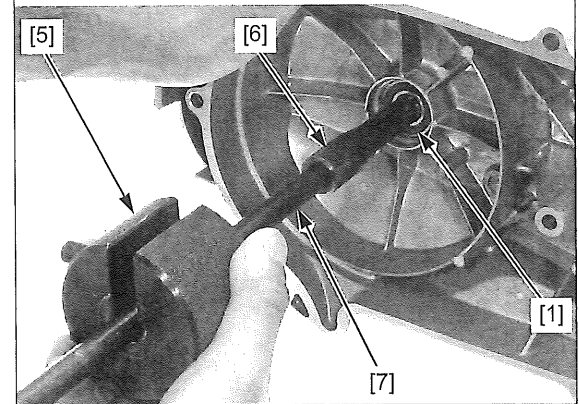
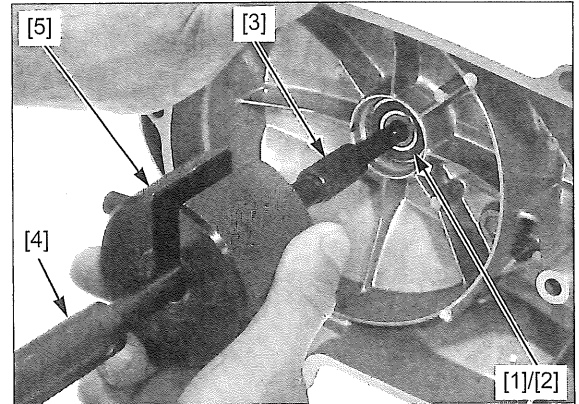

Apply engine oil to the bearing cavity.

Drive a new drive shaft bearing/bushing [1] into the left crankcase cover squarely until it is fully seated, using the special tools.

**TOOLS:**

[2] Driver	07749-0010000
[3] Attachment, 32 x 35 mm	07746-0010100
[4] Pilot, 10 mm	07746-0040100

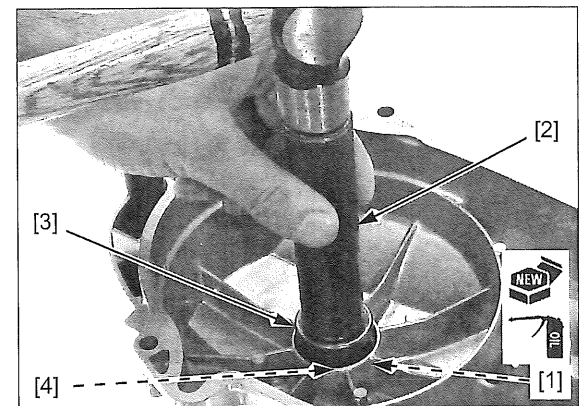

*Install the snap ring with the chamfered edge facing the bearing.*

Install the snap ring [1] to the left crankcase cover groove.

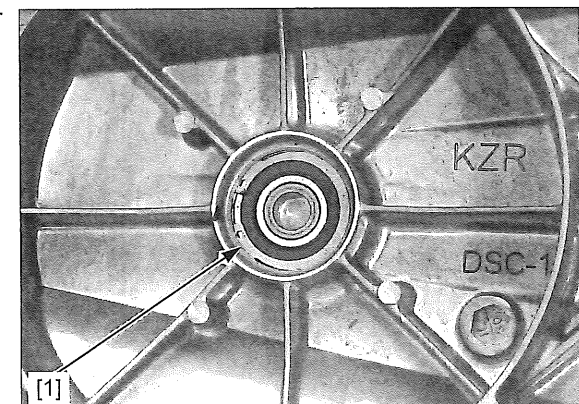

## DRIVE PULLEY/DRIVEN PULLEY/CLUTCH

### INSTALLATION

Clean the gasket mating surface.

Clean any oil and grease from the bearing bushing [1] on the left crankcase cover.

Install the dowel pins [2].

Install a new cover gasket [3].

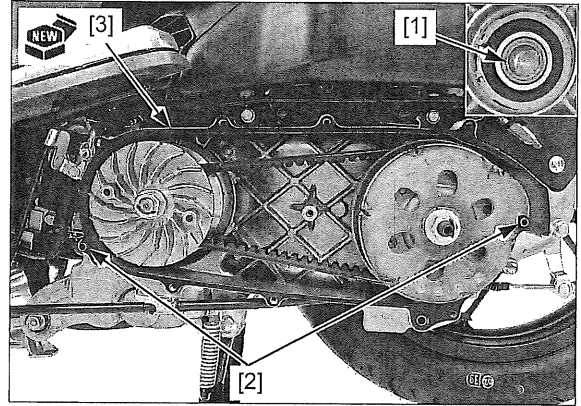

Install the left crankcase cover [1], rear brake cable clamp [2] and tighten the bolts [3].

Install the left side cover (page 2-8).

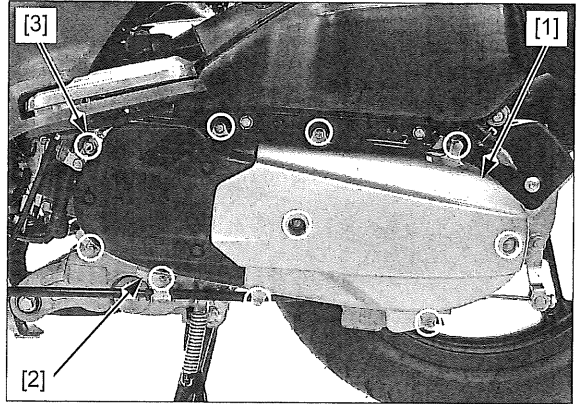

## DRIVE BELT

### REPLACEMENT

Remove the following:

- Drive pulley face (page 12-9)
- Clutch outer (page 12-12)

Slide off the clutch/driven pulley assembly [1] from the drive shaft [2].

Remove the drive belt [3] and replace it with a new one.

*Do not get grease on the drive shaft splines from the driven face inside.*

Install the clutch/driven pulley assembly onto the drive shaft.

Install the following:

- Clutch outer (page 12-20)
- Drive pulley face (page 12-11)

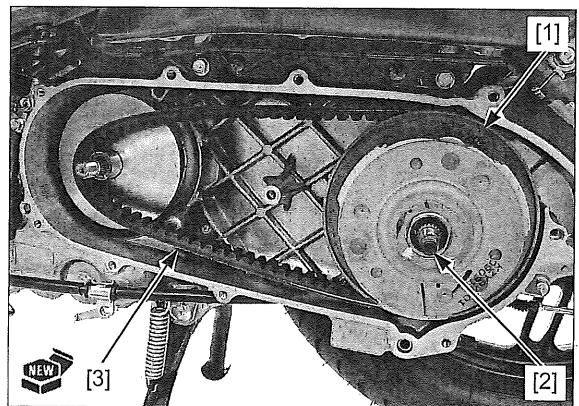



## DRIVE PULLEY

### REMOVAL

Remove the left crankcase cover (page 12-6).

Hold the drive pulley face [1] with special tool and loosen the drive pulley face nut [2].

#### TOOL:

[3] Clutch center holder 07725-0030000

Remove the following:

- Nut
- Collar [4]
- Drive pulley face

Release the drive belt [5] from the drive pulley boss.

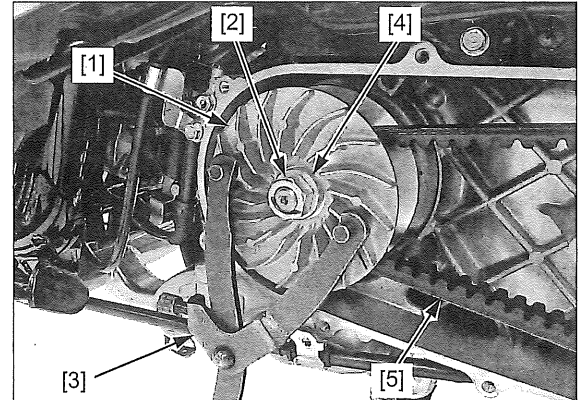

Remove the movable drive face assembly [1] while holding the back of the face (ramp plate [2]) and drive face boss [3].

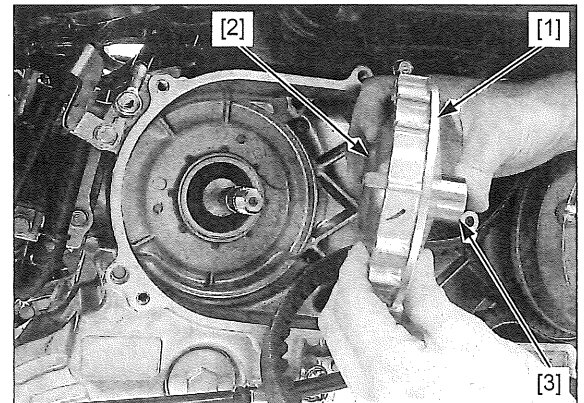

### DISASSEMBLY/ASSEMBLY ('13 MODEL)

Remove the following:

- Drive face boss [1]
- Ramp plate [2]
- Slide pieces [3]
- Weight rollers [4]

Assembly is in the reverse order of disassembly.

- Clean any oil and grease from the weight rollers and movable drive face [5].

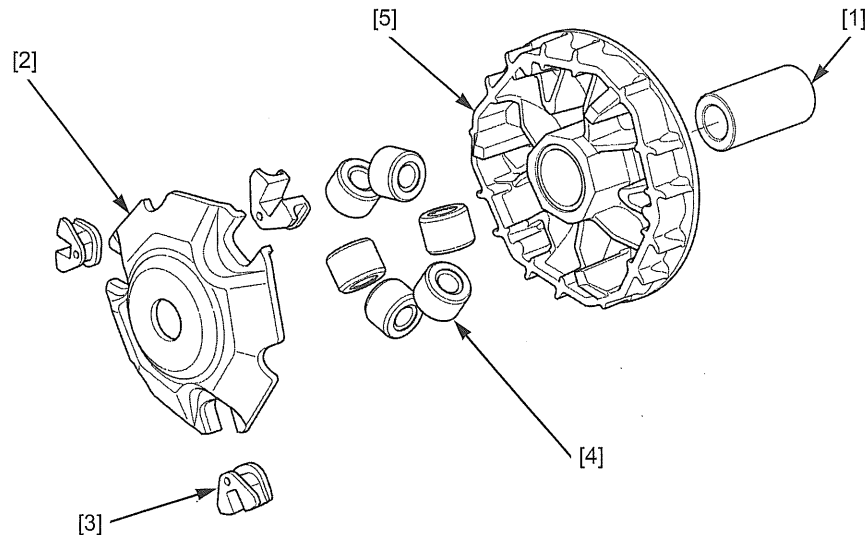

## DRIVE PULLEY/DRIVEN PULLEY/CLUTCH

### DISASSEMBLY/ASSEMBLY (AFTER '13 MODEL)

Remove the following:

- Drive face boss [1]
- Oil seal [2]
- Ramp plate [3]
- Slide pieces [4]
- Weight rollers [5]

Assembly is in the reverse order of disassembly.

- Clean any oil and grease from the weight rollers and movable drive face [6].

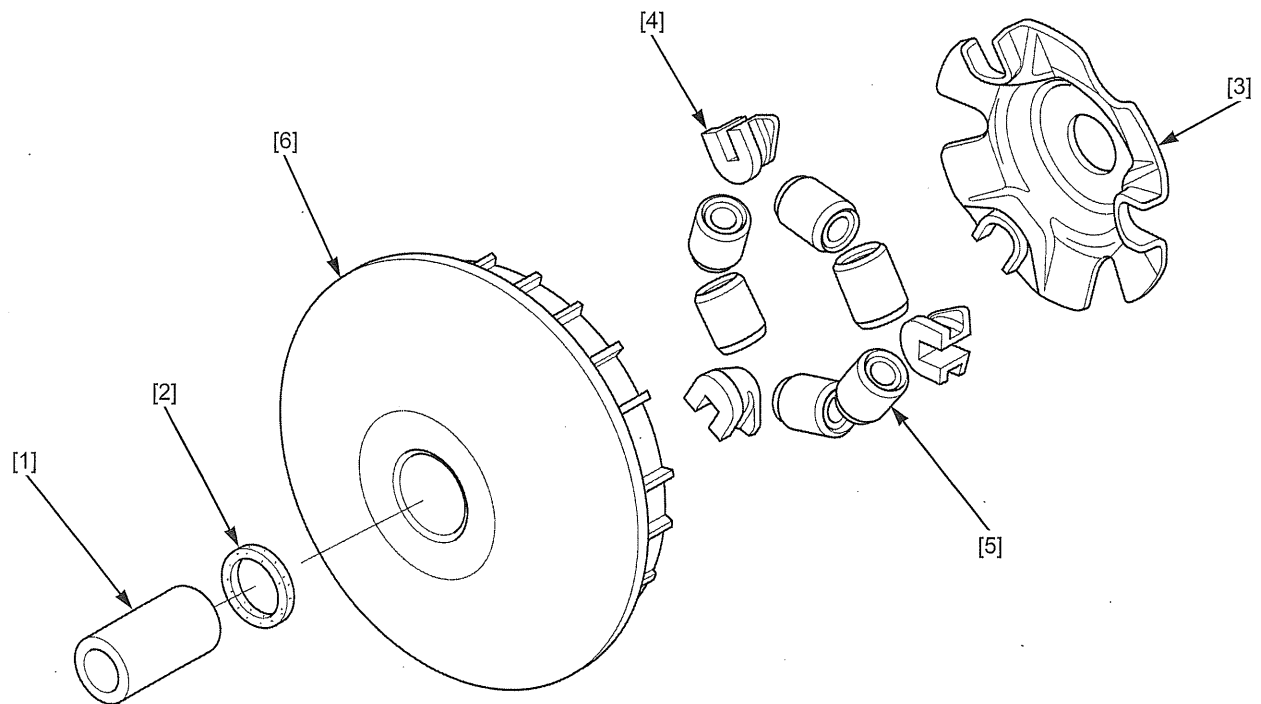

### INSPECTION

#### DRIVE PULLEY FACE

Check the drive pulley face [1] for scratches, scoring or damage.

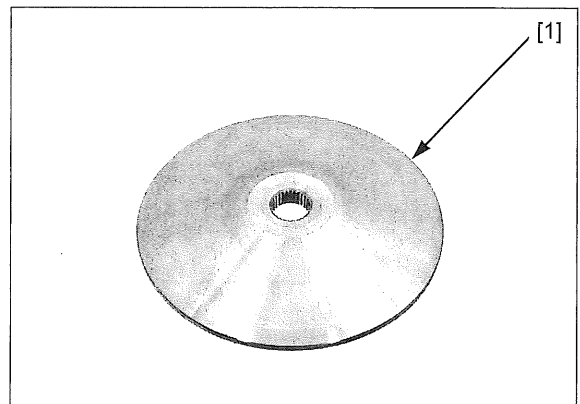

### WEIGHT ROLLER

Check each roller for abnormal wear.  
Measure the weight roller O.D.

**SERVICE LIMIT: 19.5 mm (0.77 in)**

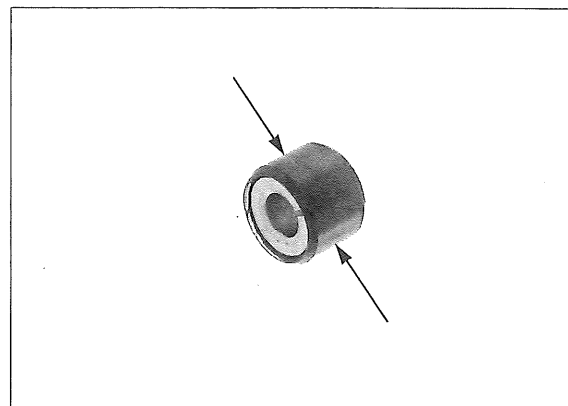

### DRIVE FACE BOSS

Check the drive face boss for wear or damage.  
Measure the drive face boss O.D.

**SERVICE LIMIT: 23.93 mm (0.942 in)**

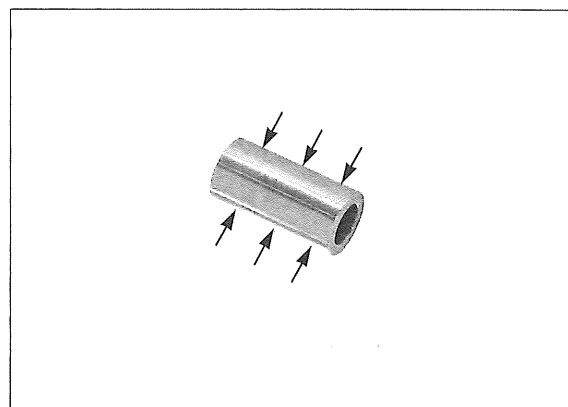

### MOVABLE DRIVE FACE

Check the movable drive face for scratches, scoring or damage.  
Measure the drive face bushing I.D.

**SERVICE LIMIT: 24.08 mm (0.948 in)**

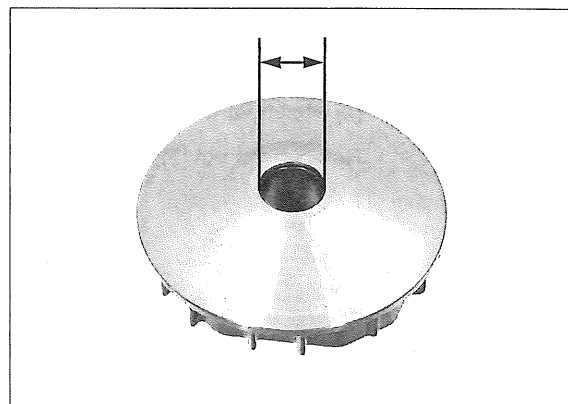

### INSTALLATION

Clean any oil and grease from the drive face and drive belt.

Install the movable drive face assembly [1] onto the crankshaft while holding the ramp plate [2] and drive face boss [3].

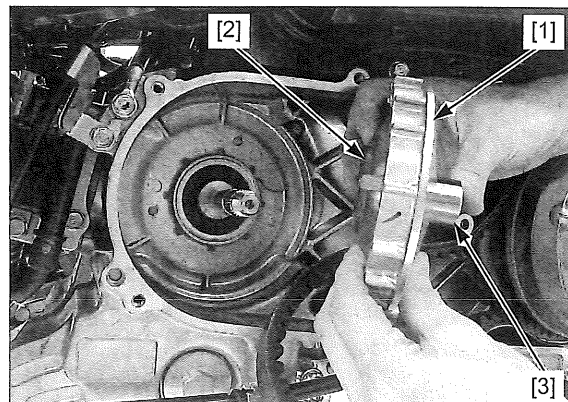

## DRIVE PULLEY/DRIVEN PULLEY/CLUTCH

Set the drive belt [1] and install the drive pulley face [2] while aligning its splines with crankshaft splines.

Make sure that the drive pulley face is fully seated on the drive face boss [3].

Apply engine oil to the left crankshaft threads.

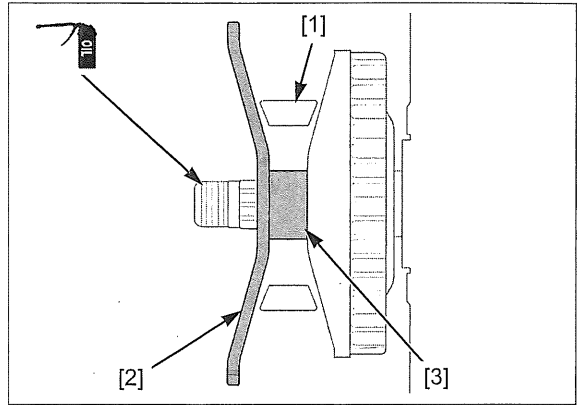

Apply engine oil to the drive pulley face nut [1] threads and seating surface then install it with the collar [2].

Hold the drive pulley face [3] with the special tool and tighten the nut to the specified torque.

### TOOL:

[4] Clutch center holder 07725-0030000

**TORQUE: 59 N·m (6.0 kgf·m, 44 lbf·ft)**

Install the left crankcase cover (page 12-8).

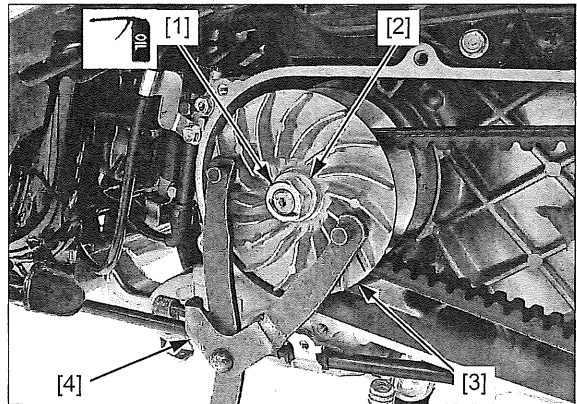

## CLUTCH/DRIVEN PULLEY

### REMOVAL

Remove the left crankcase cover (page 12-6).

*Use the special tool when loosening the lock nut. Holding the rear wheel or rear brake will damage the final reduction system.*

Hold the clutch outer [1] with the special tool.

### TOOL:

[2] Flywheel holder 07725-0040001

Remove the nut [3], washer [4] and clutch outer.

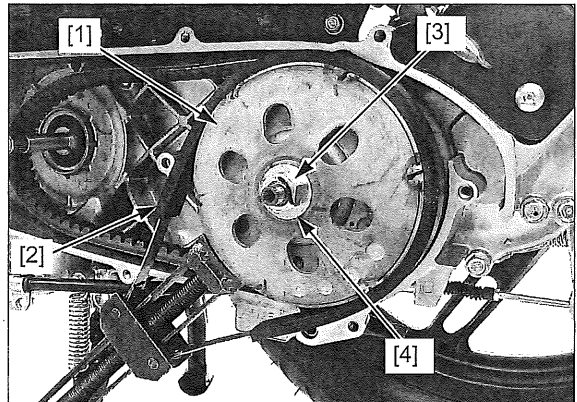

Hold the clutch/ driven pulley assembly [1] and compress the drive face spring by turning movable driven face clockwise until it stops.

Remove the drive belt [2] from the clutch/ driven pulley assembly while removing the clutch/ driven pulley assembly from the drive shaft.

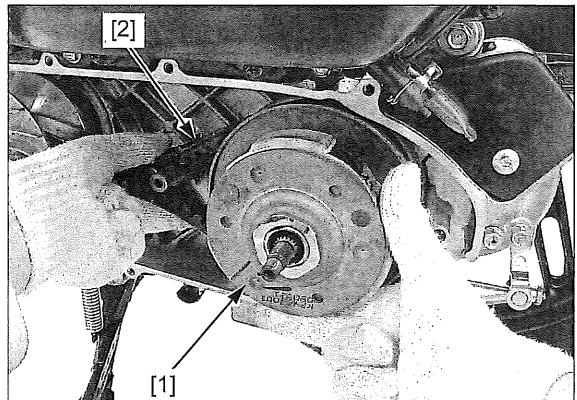

**DISASSEMBLY**

**CLUTCH/DRIVEN PULLEY**

Set the clutch spring compressor [1] onto the clutch/driven pulley [2] by aligning the bosses of the compressor with the holes of the clutch.

**TOOL:**

[1] Clutch spring compressor 07LME-GZ40201 or 07960-KM1000B (U.S.A. only)

Hold the clutch/driven pulley by turning the clutch spring compressor clockwise.

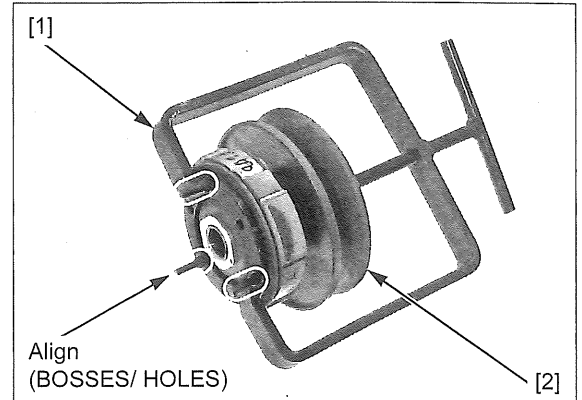

Hold the clutch spring compressor in a vise.

Remove the clutch/driven pulley nut [1] using the special tool.

**TOOL:**

[2] Socket wrench, 39 x 41 mm 07GMA-KS40100 or equivalent commercially available in U.S.A.

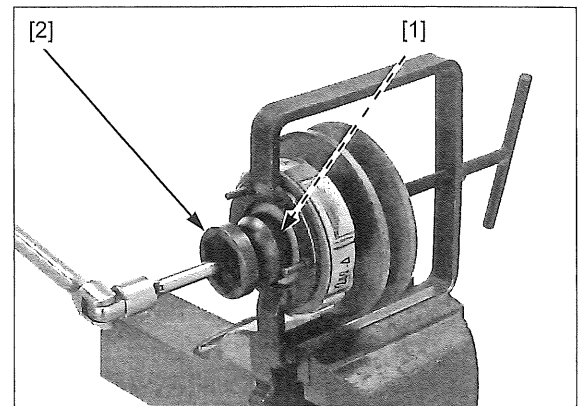

Loosen the clutch spring compressor gradually and remove the following:

- Clutch assembly [1]
- Spring seat [2]
- Driven face spring [3]
- Driven pulley assembly [4]

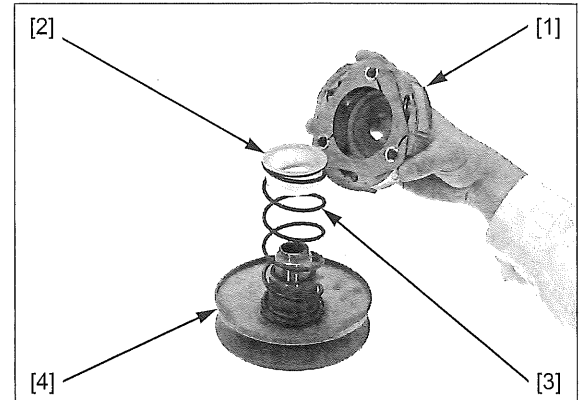

**CLUTCH**

Remove the E-clips [1] and plate [2].

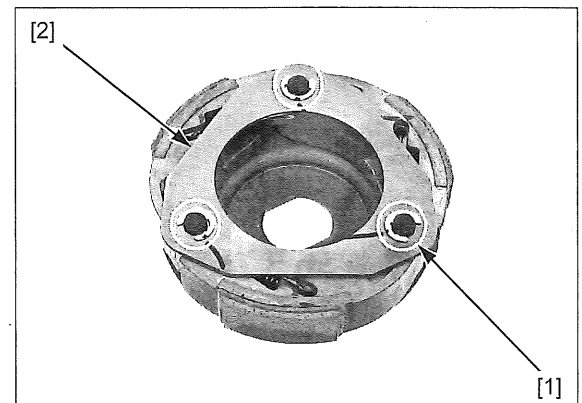

## DRIVE PULLEY/DRIVEN PULLEY/CLUTCH

Unhook and remove the shoe springs [1].  
Remove the clutch shoes [2] from the drive plate.

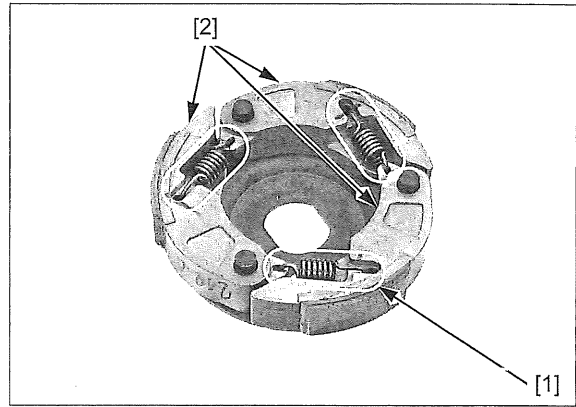

Remove the damper rubbers [1] from the drive plate [2].

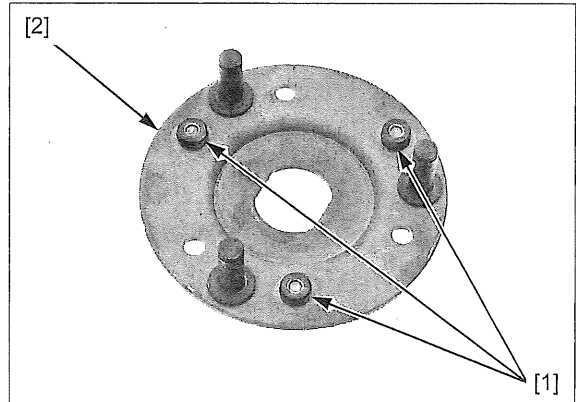

### DRIVEN PULLEY

Remove the seal collar [1].

Remove the guide pins [2] and guide rollers [3] from the driven face [4].

Remove the movable driven face [5] from the driven face.

Remove the O-rings [6] and oil seals [7] from the movable driven face.

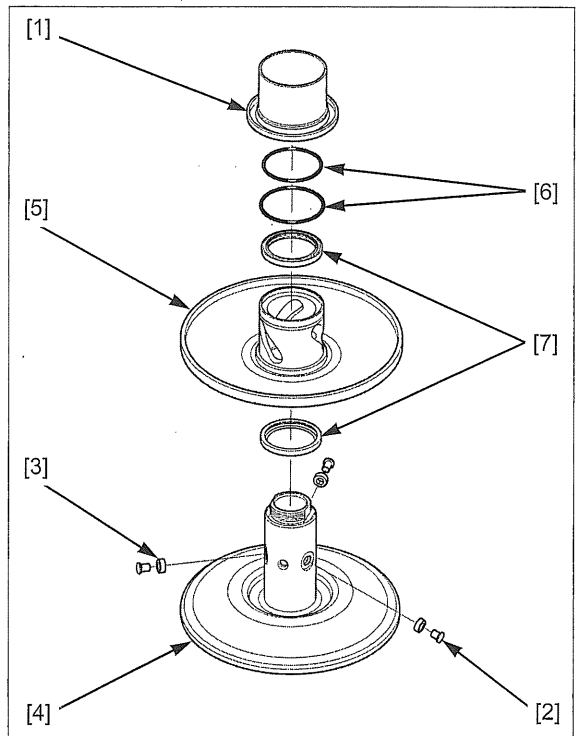

### INSPECTION

#### NOTE:

For clutch shoes inspection (page 3-23).

### CLUTCH OUTER

Check the clutch outer for wear or damage.

Measure the clutch outer I.D.

**SERVICE LIMIT: 125.5 mm (4.94 in)**

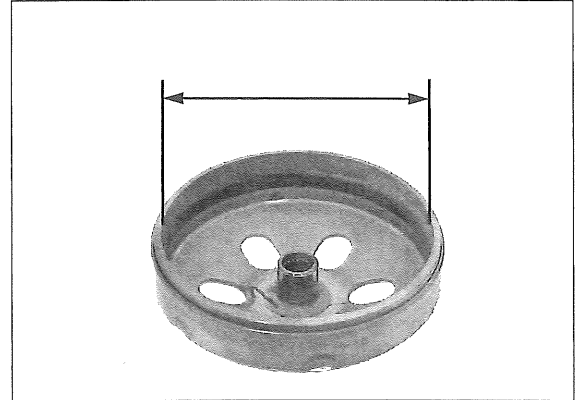

### DRIVEN FACE SPRING

Measure the driven face spring free length.

**SERVICE LIMIT: 146.6 mm (5.77 in)**

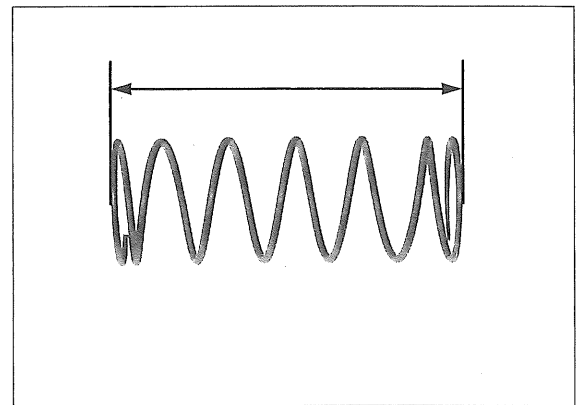

### DRIVEN FACE

Check the driven face for scratches, scoring or damage.

Measure the driven face boss O.D.

**SERVICE LIMIT: 33.94 mm (1.336 in)**

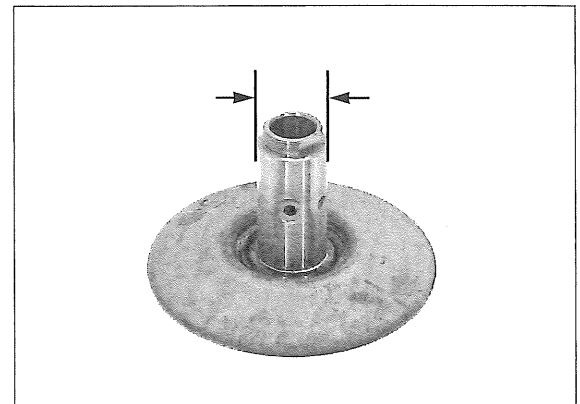

### MOVABLE DRIVEN FACE

Check the movable driven face for scratches, scoring or damage.

Check the guide grooves for stepped wear or damage.

Measure the movable driven face I.D.

**SERVICE LIMIT: 34.06 mm**

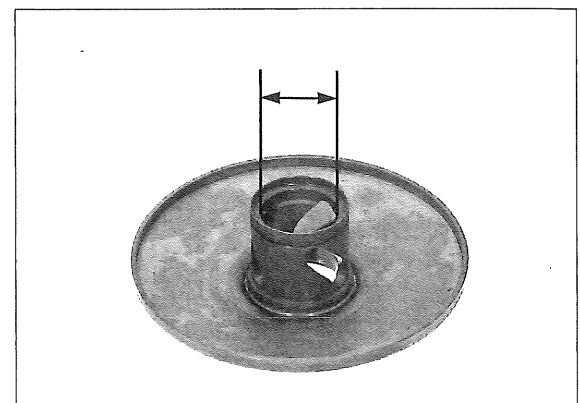

## DRIVE PULLEY/DRIVEN PULLEY/CLUTCH

### DRIVEN FACE BEARING REPLACEMENT

Remove the driven face needle bearing [1] using the special tools.

**TOOLS:**

[2] Bearing remover, 20 mm	07936-3710600
[3] Remover handle	07936-3710100
[4] Remover weight	07741-0010201 or 07936-371020A (U.S.A. only)

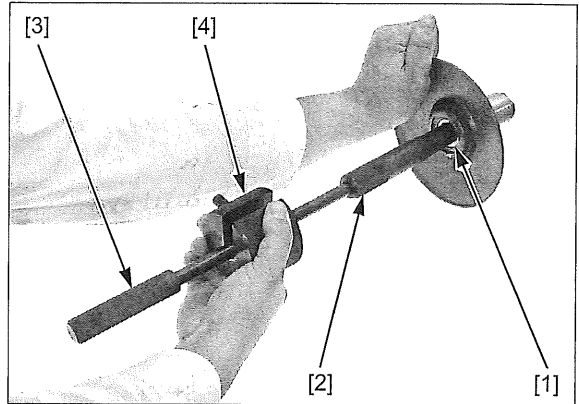

Remove the snap ring [1] and drive the ball bearing [2] out of the driven face.

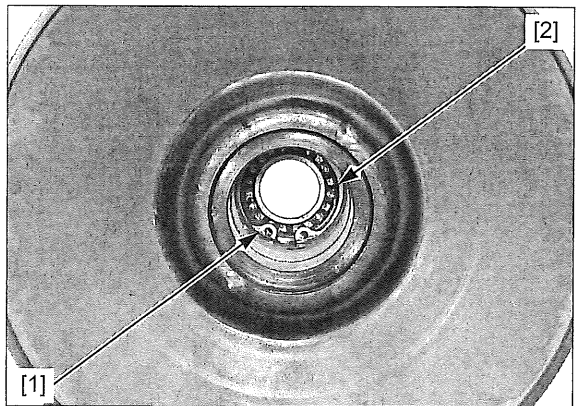

Pack new ball bearing [1] with grease (NIPPON OIL P/ U N6B or N6C or equivalent).

Install the ball bearing into the driven face squarely until it is fully seated with its sealed side facing down, using the special tools.

**TOOLS:**

[2] Driver	07749-0010000
[3] Pilot, 28 mm	07746-0041100

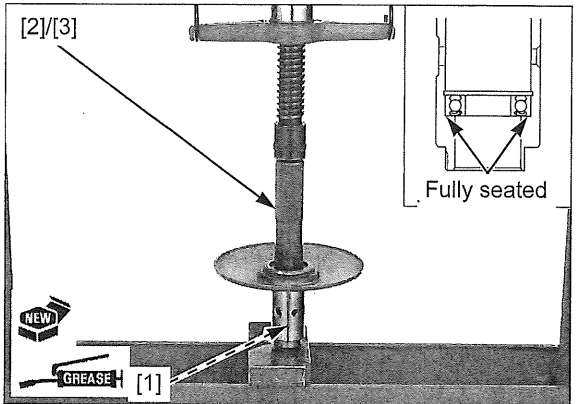

Install the snap ring [1] to the groove on the driven face securely.

Apply 7.3 – 8.3 g of grease (Shell ALVANIA R3 or IDEMITSU AUTOREX B or NIPPON OIL POWERNOG WB3 or equivalent) to the driven face inner surface as shown.

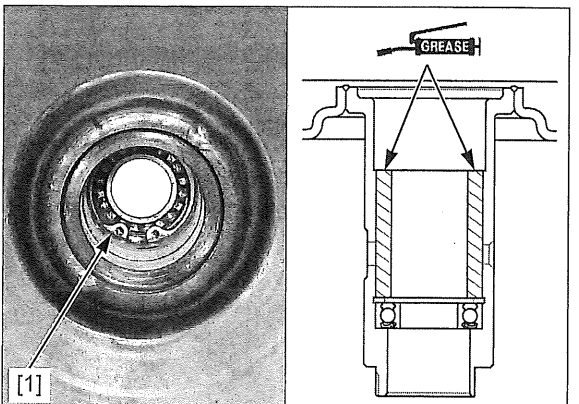



## DRIVE PULLEY/DRIVEN PULLEY/CLUTCH

Apply grease (Shell RETINEX LX2 or NIPPON OIL P/U N6B or equivalent) to a new needle bearing [1].

Set the needle bearing with its sealed side facing up. Press the needle bearing into the driven face until it is flush with the driven face surface as shown.

### TOOLS:

[2] Driver	07749-0010000
[3] Attachment, 28 x 30 mm	07946-1870100
[4] Pilot, 20 mm	07746-0040500

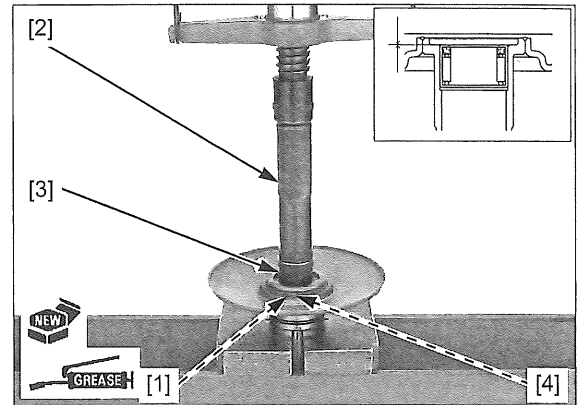

### ASSEMBLY

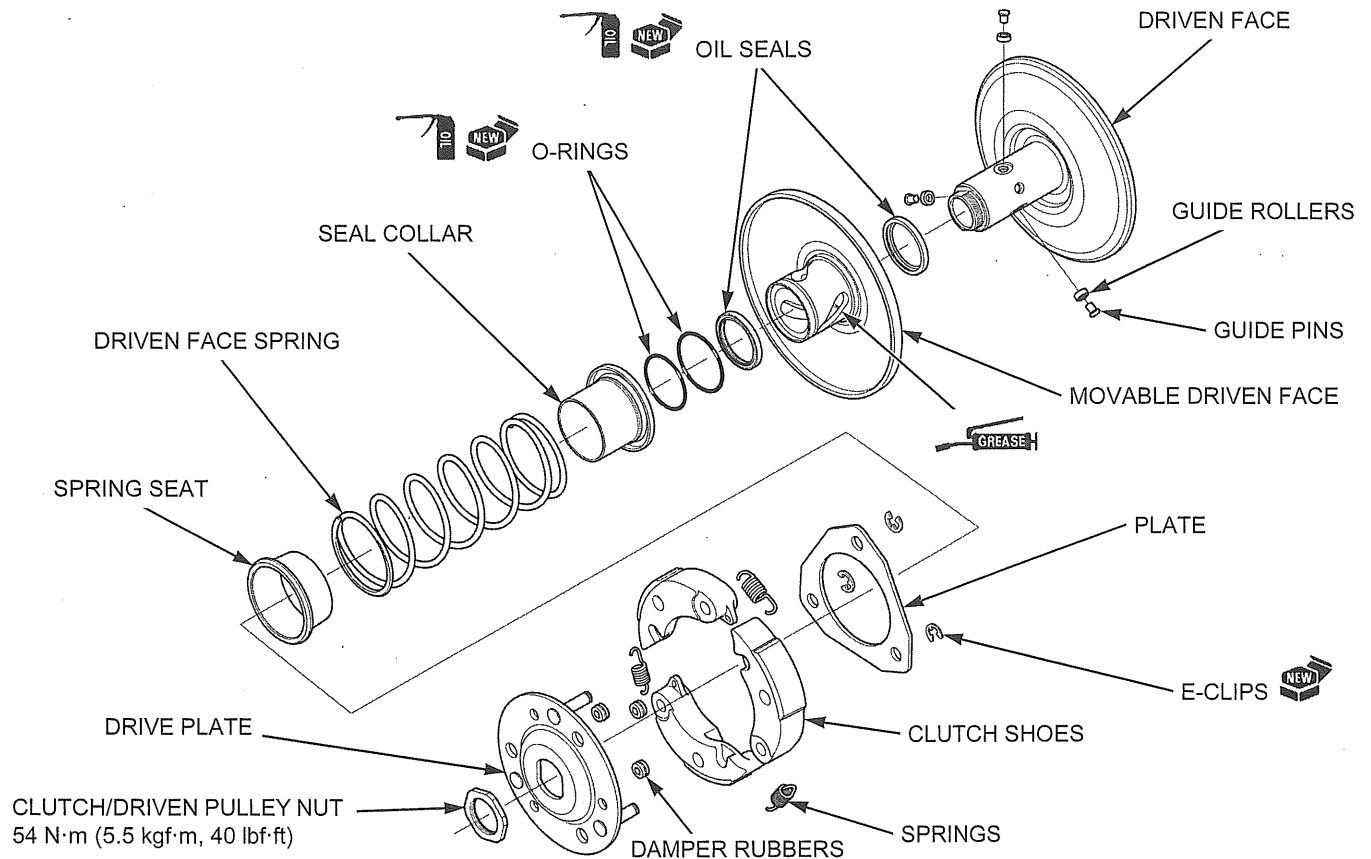

### DRIVEN PULLEY

Apply engine oil to new oil seal [1] lips and install them into the movable driven face.

Apply engine oil to new O-rings [2] and install them into the movable driven face grooves.

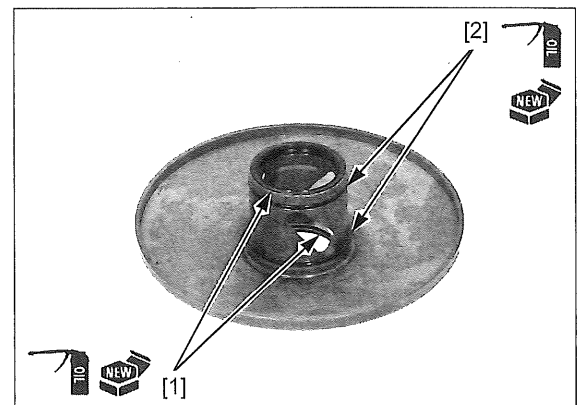

## DRIVE PULLEY/DRIVEN PULLEY/CLUTCH

Clean any oil and grease from the pulley face [1].

Install the movable driven face [2] onto the driven face.  
Install the guide rollers [3] and guide pins [4].

Apply 1.7 – 2.2 g of grease (Shell ALVANIA R3 or IDEMITSU AUTOREX B or NIPPON OIL POWERNOG WB3 or equivalent) to each guide groove.

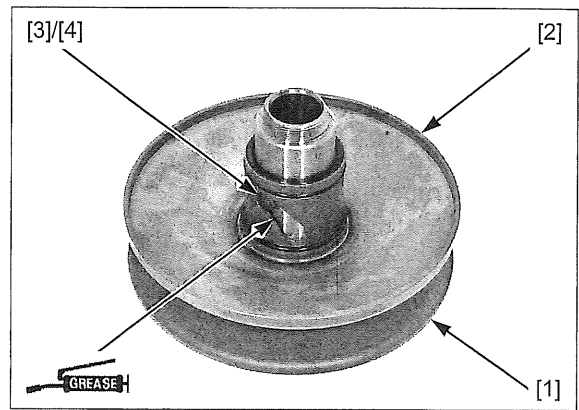

Install the seal collar [1] to the driven pulley.

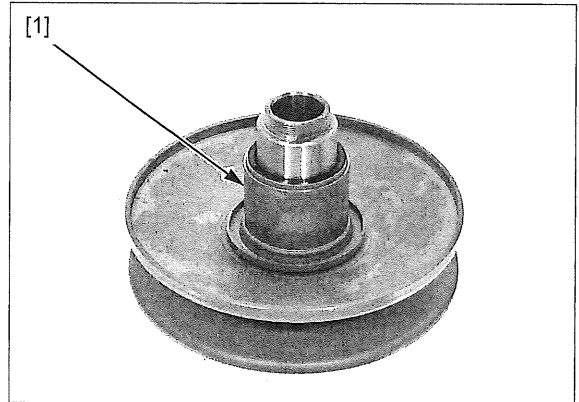

### CLUTCH

Install the damper rubbers [1] onto the drive plate [2].

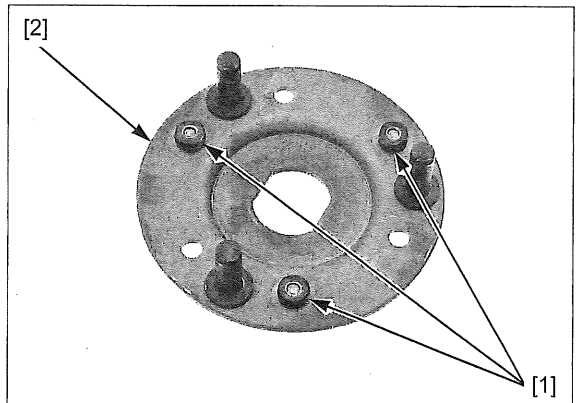

Install the clutch shoes [1] to the drive plate bosses [2].  
Turn the clutch shoes so that the damper rubbers [3] are positioned in the grooves of the clutch shoes.

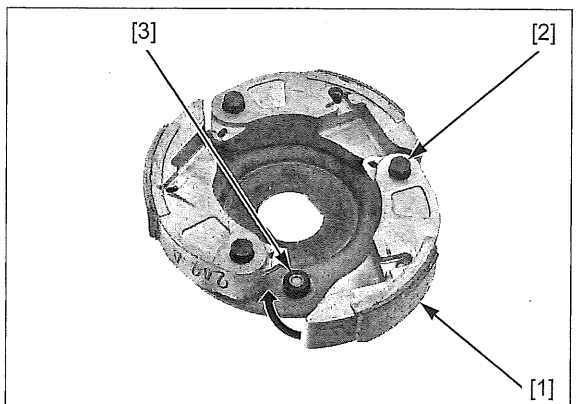

## DRIVE PULLEY/DRIVEN PULLEY/CLUTCH

Hook the shoe spring [1] ends to the clutch shoe holes with their long ends [2] facing the center holes and short ends [3] facing the neighboring shoe holes as shown.

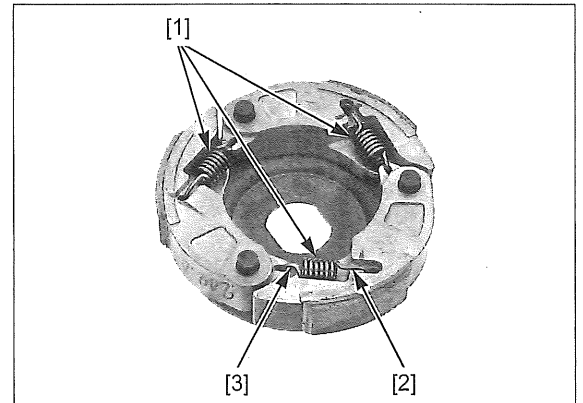

Install the plate [1] and new E-clips [2].  
*Install the E-clips with their open side facing out as shown.*

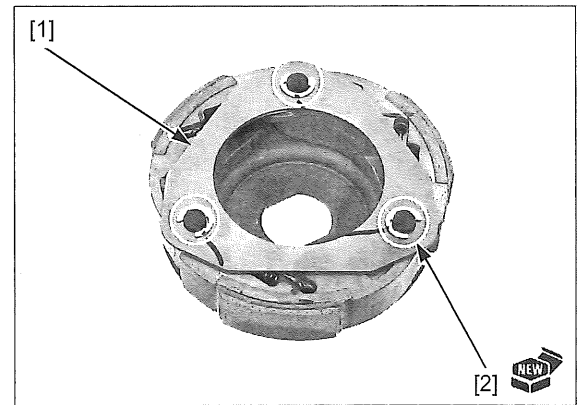

### CLUTCH/DRIVEN PULLEY

Assemble the following:

- Driven pulley assembly [1]
- Driven face spring [2]
- Spring seat [3]
- Clutch assembly [4]

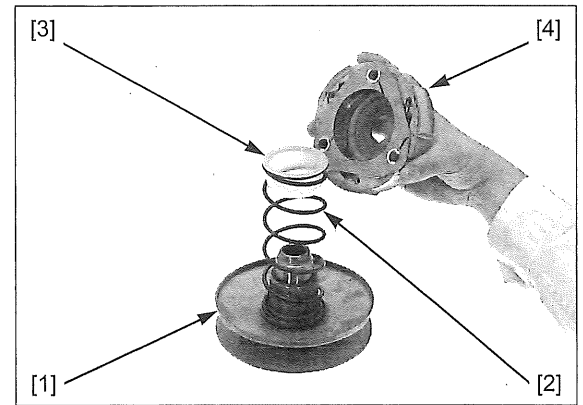

Set the clutch spring compressor [1] over the clutch/driven pulley assembly aligning the bosses of the compressor with the holes of the clutch.

### TOOL:

[1] Clutch spring compressor 07LME-GZ40201 or 07960-KM1000B (U.S.A. only)

*Be careful not to damage the driven face threads.* Compress the driven face spring while aligning the cutout of the driven face threads with the drive plate hole and install the clutch/driven pulley nut.

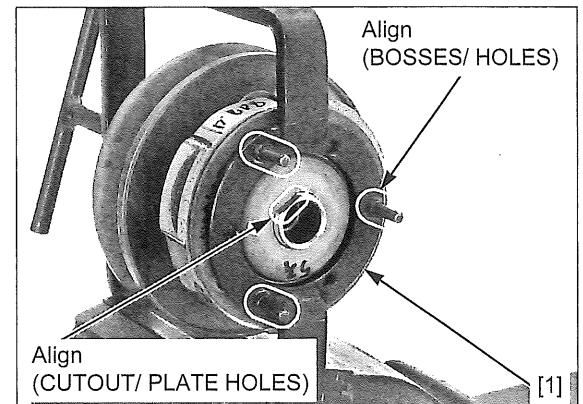

## DRIVE PULLEY/DRIVEN PULLEY/CLUTCH

Hold the spring compressor [1] in a vice.

*Install the nut with its chamfered side facing in.*

Tighten the clutch/driven pulley nut [2] to the specified torque, using the socket wrench [3].

**TOOL:**

**[3] Socket wrench, 39 x 41 mm 07GMA-KS40100 or equivalent commercially available in U.S.A.**

**TORQUE: 54 N·m (5.5 kgf·m, 40 lbf·ft)**

Remove the spring compressor from the clutch/driven pulley assembly.

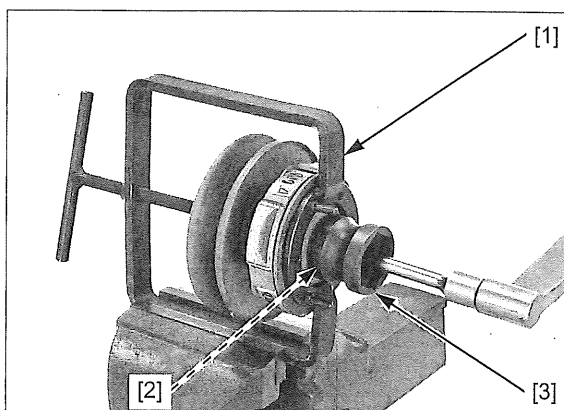

### INSTALLATION

Clean any oil and grease from the driven face and drive belt [1].

Hold the clutch/driven pulley assembly [2] and compress the drive face spring by turning movable driven face [3] clockwise until it stops.

Set the drive belt onto the pulley groove while holding the movable driven face.

*Do not get grease on the drive shaft splines from the driven face inside.*

Install the clutch/driven pulley assembly onto the drive shaft.

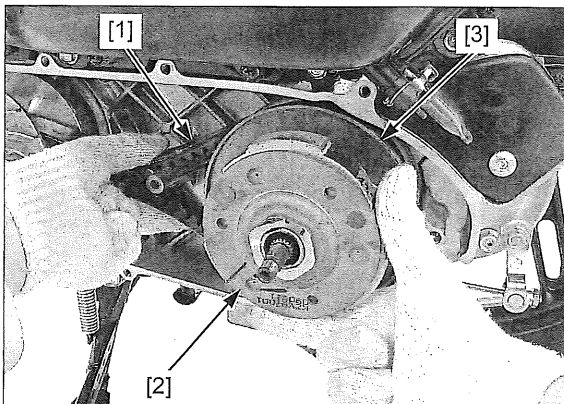

Clean any oil and grease from the clutch outer [1].

Install the clutch outer while aligning its splines with drive shaft splines.

Install the washer [2] and clutch outer nut [3].

Hold the clutch outer with the special tool and tighten the clutch outer nut to the specified torque.

**TOOL:**

**[4] Flywheel holder 07725-0040001**

**TORQUE: 49 N·m (5.0 kgf·m, 36 lbf·ft)**

Install the left crankcase cover (page 12-8).

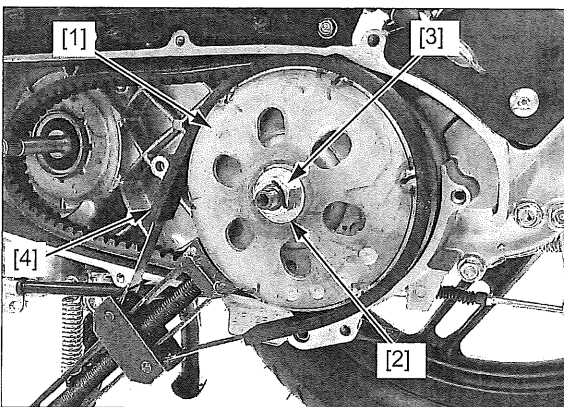

# 13. FINAL REDUCTION

---

COMPONENT LOCATION ..... 13-2

SERVICE INFORMATION ..... 13-3

TROUBLESHOOTING ..... 13-5

FINAL REDUCTION CASE  
SEPARATION ..... 13-6

FINAL REDUCTION INSPECTION ..... 13-6

FINAL REDUCTION BEARING  
REPLACEMENT ..... 13-8

FINAL REDUCTION CASE ASSEMBLY .. 13-12

**FINAL REDUCTION**

**COMPONENT LOCATION**

23 N·m (2.3 kgf·m, 17 lbf·ft)

23 N·m (2.3 kgf·m, 17 lbf·ft)

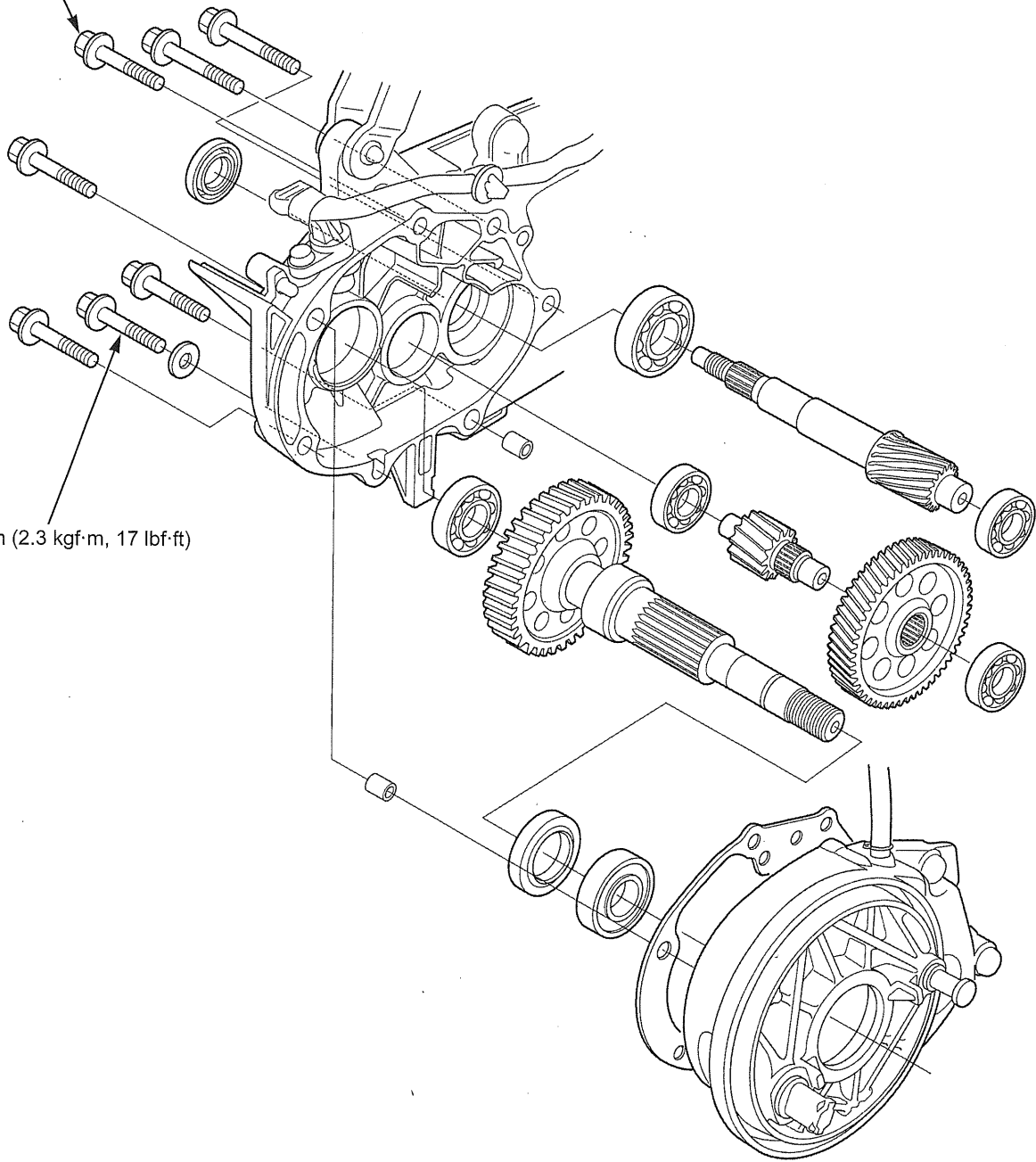

## SERVICE INFORMATION

### GENERAL

- The final reduction can be serviced with the engine installed in the frame.
- When installing the driveshaft, be sure to use the special tools; position the special tools on the bearing inner race and pull the driveshaft into the bearing until it is fully seated.

### SPECIFICATIONS

Unit: mm (in)



ITEM		SPECIFICATIONS
Final reduction oil capacity	After draining	0.12 liter (0.13 US qt, 0.11 Imp qt)
	After disassembly	0.14 liter (0.15 US qt, 0.12 Imp qt)
Recommended final reduction oil		Pro Honda HP4M 4-stroke oil (U.S.A. and Canada) or equivalent motor oil API service classification: SJ or higher JASO T 903 standard: MB Viscosity: SAE 10W-30

### TORQUE VALUES





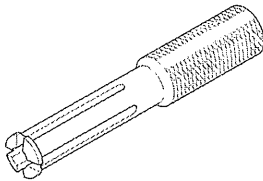
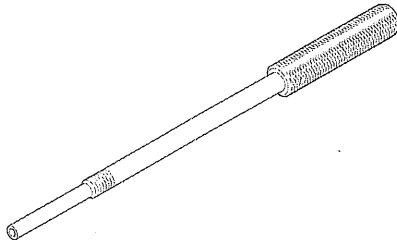
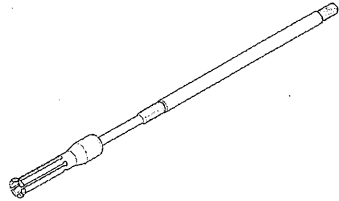
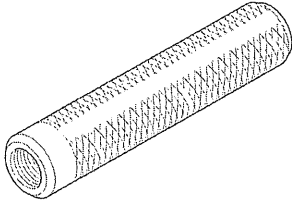
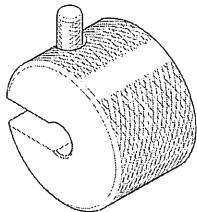
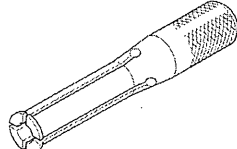
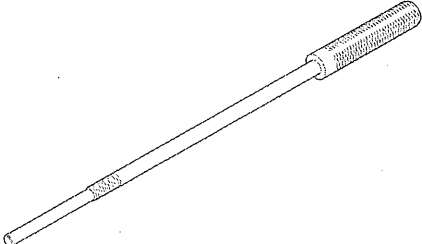
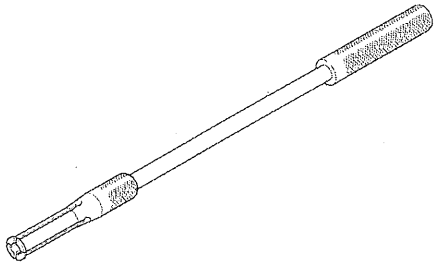
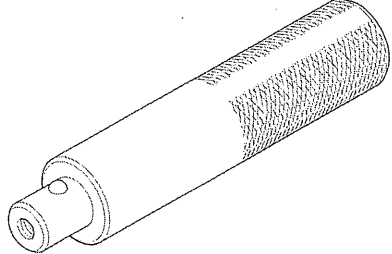
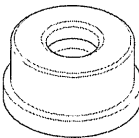

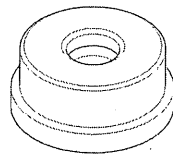
ITEM	Q'TY	THREAD DIA. (mm)	TORQUE N·m (kgf·m, lbf·ft)	REMARKS
Final reduction case bolt	6	8	23 (2.3, 17)	
Final reduction oil drain bolt	1	8	23 (2.3, 17)	

# FINAL REDUCTION

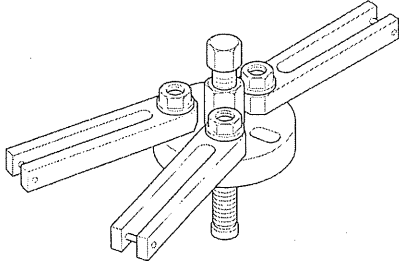
## TOOLS

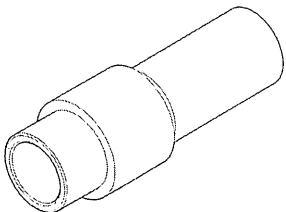
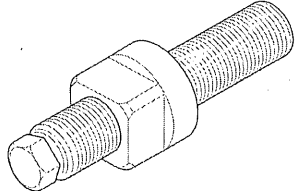
<p>Bearing remover head, 12 mm 07936-1660110</p>  <p>(Not available in U.S.A.)</p>	<p>Bearing remover shaft, 12 mm 07936-1660120</p>  <p>(Not available in U.S.A.)</p>	<p>Bearing remover, 12 mm 07936-166010A (U.S.A. only)</p> 
<p>Remover handle 07936-3710100</p> 	<p>Remover weight 07741-0010201</p>  <p>or 07936-371020A (U.S.A. only)</p>	<p>Bearing remover head, 15 mm 07936-KC10200</p>  <p>(Not available in U.S.A.)</p>
<p>Bearing remover shaft, 15 mm 07936-KC10100</p>  <p>(Not available in U.S.A.)</p>	<p>Bearing remover, 15 mm 07936-KC10500 (U.S.A. only)</p> 	<p>Driver 07749-0010000</p> 
<p>Attachment, 37 x 40 mm 07746-0010200</p> 	<p>Pilot, 12 mm 07746-0040200</p> 	<p>Attachment, 42 x 47 mm 07746-0010300</p> 

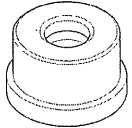
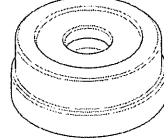

<p>Pilot, 15 mm 07746-0040300</p> 	<p>Case puller 07SMC-0010001</p>  <p>or 07HAC-PK4010B (U.S.A. only)</p>	<p>Pilot, 20 mm 07746-0040500</p> 
<p>Assembly collar 07965-GM00100</p> 	<p>Assembly shaft 07965-1660200</p> 	<p>Assembly collar attachment 07965-GM00200</p> 
<p>Attachment, 32 x 35 mm 07746-0010100</p> 	<p>Attachment, 51.5 mm 07946-3290000</p> 	<p>Pilot, 25 mm 07746-0040600</p> 

## TROUBLESHOOTING

### Engine starts but scooter won't move

- Damaged final reduction
- Seized final reduction
- Faulty drive pulley (page 12-10)
- Faulty driven pulley/clutch (page 12-14)

### Abnormal noise

- Worn, seized or chipped gears
- Worn or damaged final reduction bearing

### Oil leak

- Oil level too high
- Worn or damaged oil seal
- Cracked crankcase and/or final reduction case

## FINAL REDUCTION

### FINAL REDUCTION CASE SEPARATION

#### NOTE:

The final reduction can be serviced with the engine installed in the frame.

Drain the final reduction oil (page 3-16).

Remove the following:

- Clutch/driven pulley (page 12-12)
- Rear wheel (page 18-5)
- Rear brake shoes (page 18-8)
- VS sensor protector (page 21-16)

Remove the final reduction case bolts [1], drain bolt [2], sealing washer [3] and final reduction case [4].

Release the rear brake cable [5] from the case.

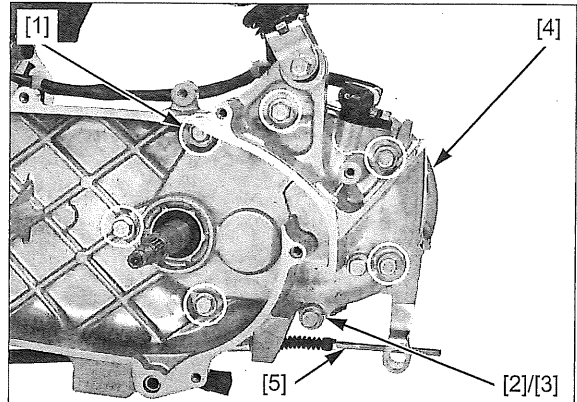

Remove the dowel pins [1] and gasket [2].

Remove the following:

- Counter gear [3]
- Countershaft [4]
- Final gear shaft [5]

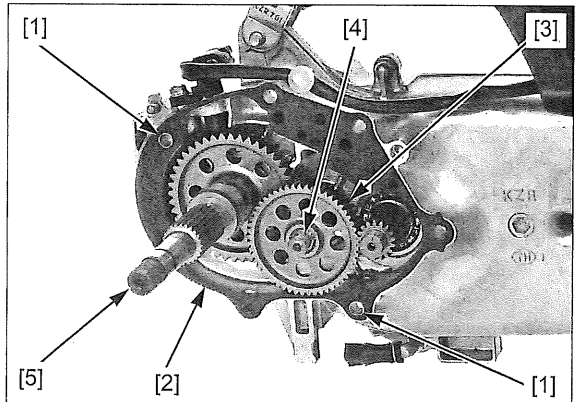

### FINAL REDUCTION INSPECTION

#### BEARING

##### LEFT CRANKCASE

Check each bearing for wear or damage.

Turn the inner race of the countershaft [1] and final gear shaft [2] bearings with your finger. The bearing should turn smoothly and quietly. Also check that the bearing outer race fits tightly in the crankcase.

Replace the bearings if they do not turn smoothly, quietly, or if they fit loosely in the crankcase.

Turn the driveshaft [3] with your hand. The bearing [4] should turn smoothly and quietly. Also check that the bearing outer race fits tightly in the crankcase and bearing inner race fits tightly on the driveshaft.

Replace the bearing if it does not turn smoothly, quietly, or if it fits loosely on the crankcase and driveshaft.

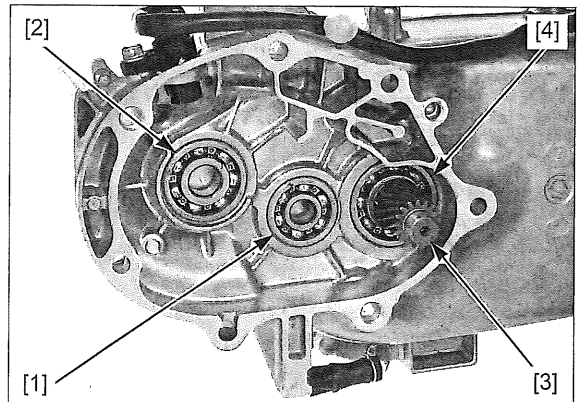

## FINAL REDUCTION CASE

Check the final reduction case bearings [1] and final gear shaft oil seal [2] for wear or damage.

Turn each bearing inner race with your finger. The bearing should turn smoothly without friction. Check that there is no clearance between the outer race and final reduction case.

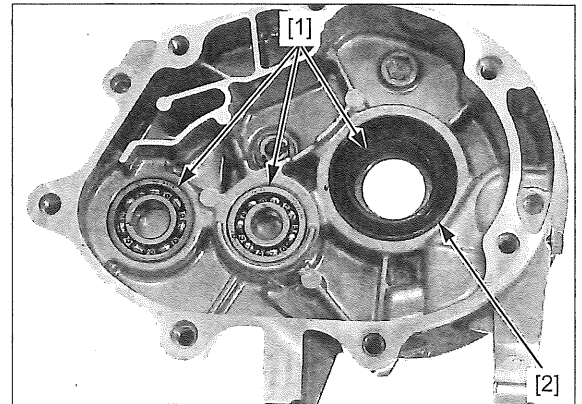

## GEAR/SHAFT

### DRIVESHAFT

Check the driveshaft [1] for bend, wear or damage.

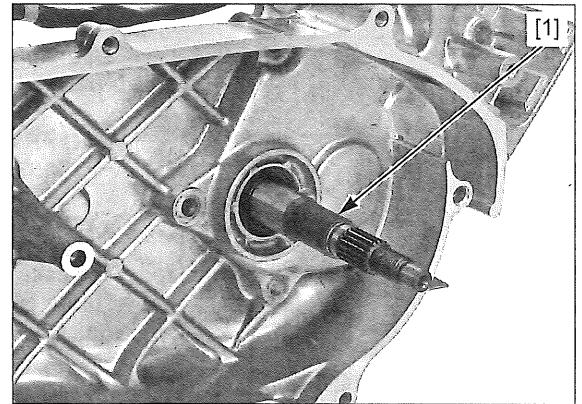

### COUNTER GEAR/COUNTERSHAFT/FINAL GEAR SHAFT

Check the countershaft [1], counter gear [2] and final gear shaft [3] for wear or damage.

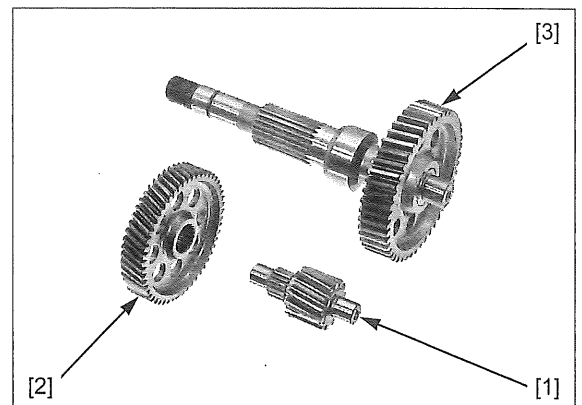

## FINAL REDUCTION

# FINAL REDUCTION BEARING REPLACEMENT

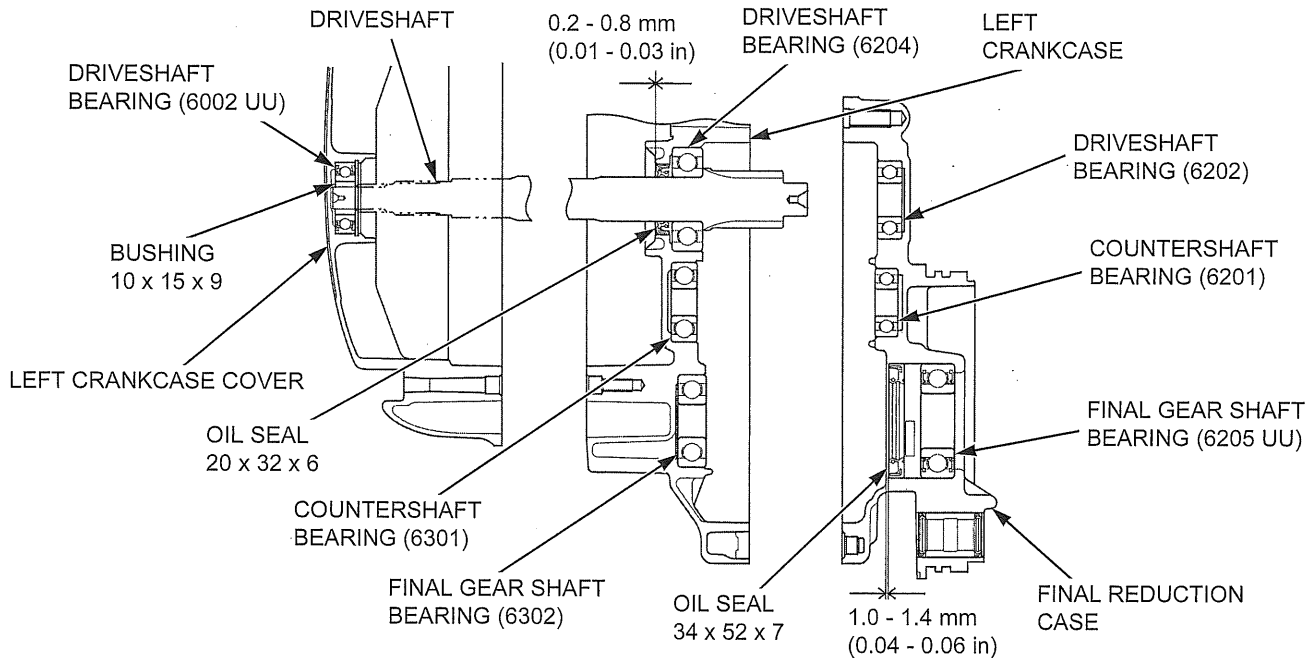

### LEFT CRANKCASE

*Be careful not to damage the final reduction case mating surface.*

Separate the final reduction case (page 13-6).

Remove the countershaft [1] and final gear shaft [2] bearings using the special tools.

#### TOOLS:

##### Countershaft bearing:

- [3] Bearing remover head, 12 mm 07936-1660110
- [4] Bearing remover shaft, 12 mm 07936-1660120
- [5] Remover weight 07741-0010201

##### Final gear shaft bearing:

- Bearing remover head, 15 mm 07936-KC10200
- Bearing remover shaft, 15 mm 07936-KC10100
- Remover weight 07741-0010201

#### U.S.A. TOOLS:

##### Countershaft bearing:

- Bearing remover, 12 mm 07936-166010A
- Remover handle 07936-3710100
- Remover weight 07936-371020A

##### Final gear shaft bearing:

- Bearing remover, 15 mm 07936-KC10500
- Remover weight 07936-371020A

Apply engine oil to each bearing [1] cavity.

*Set the bearings with their marked sides facing up.*

Drive each new bearing into the left crankcase squarely until it is fully seated, using the special tools.

#### TOOLS:

##### Countershaft bearing:

- [2] Driver 07749-0010000
- [3] Attachment, 37 x 40 mm 07746-0010200
- [4] Pilot, 12 mm 07746-0040200

##### Final gear shaft bearing:

- Driver 07749-0010000
- Attachment, 42 x 47 mm 07746-0010300
- Pilot, 15 mm 07746-0040300

Assemble the final reduction case (page 13-12).

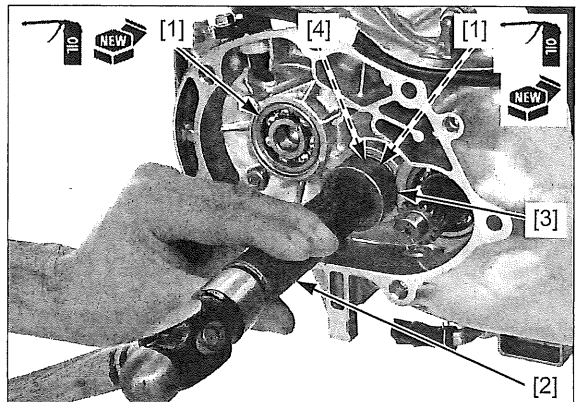
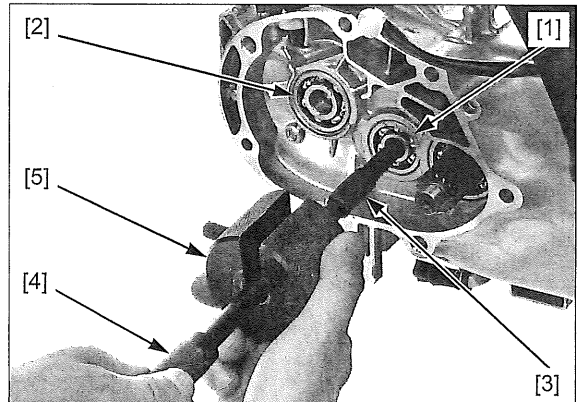

**DRIVESHAFT**

Separate the final reduction case (page 13-6).

Remove the driveshaft [1] using the special tool.

**TOOL:**

[2] Case puller

07SMC-0010001 or  
07HAC-PK4010B  
(U.S.A. only)

- If the driveshaft bearing [3] remains in the left crankcase, drive it out from the left side.
- If the bearing remains on the driveshaft, remove the bearing using a hydraulic press.

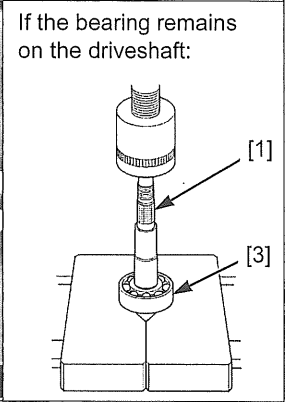
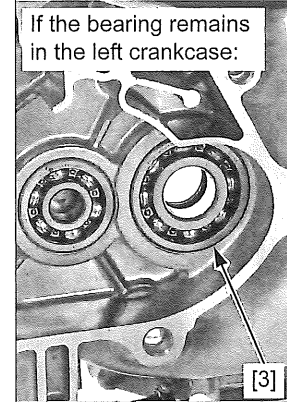
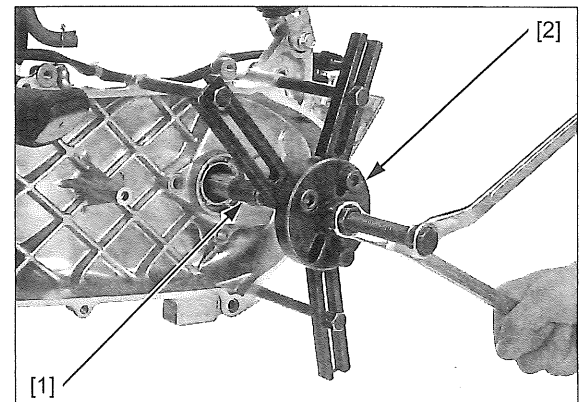

Remove the driveshaft oil seal [1].

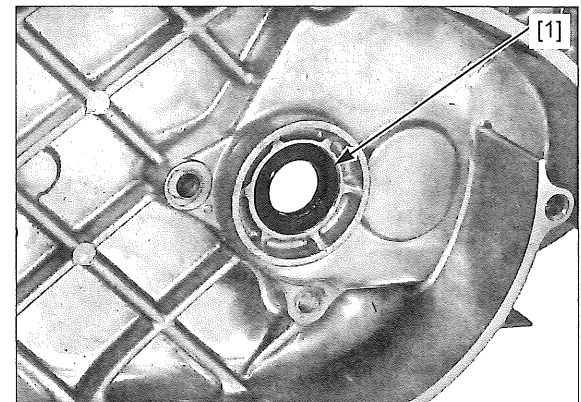

Apply engine oil to the bearing cavity.

*Set the bearing with its marked side facing up.*

Drive a new driveshaft bearing [1] into the left crankcase squarely until it is fully seated, using the special tools.

**TOOLS:**

[2] Driver

07749-0010000

[3] Attachment, 42 x 47 mm

07746-0010300

[4] Pilot, 20 mm

07746-0040500

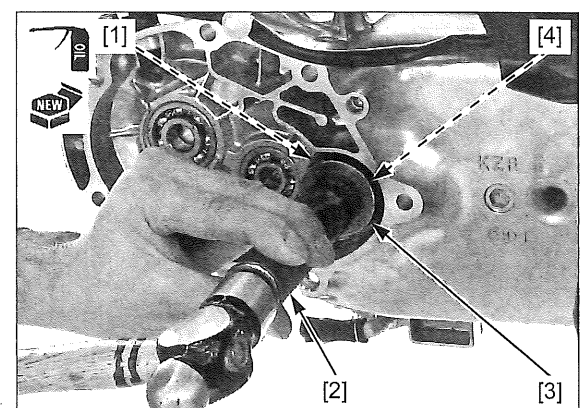

## FINAL REDUCTION

Install the driveshaft [1] into the bearing [2].  
Position the assembly collar [3] on the driveshaft bearing inner race and pull the driveshaft [4] into the bearing until it is fully seated.

**TOOLS:**

[3] Assembly collar	07965-GM00100
[4] Assembly shaft	07965-1660200
[5] Assembly collar attachment	07965-GM00200

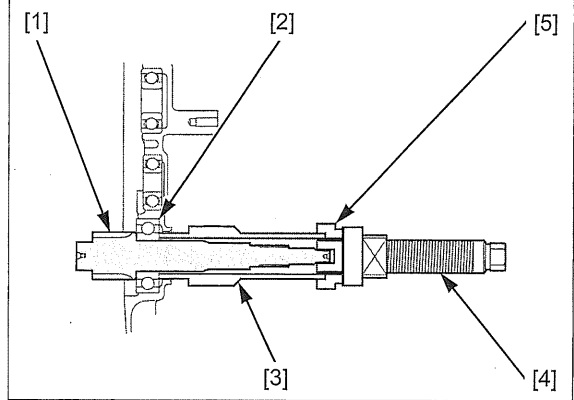
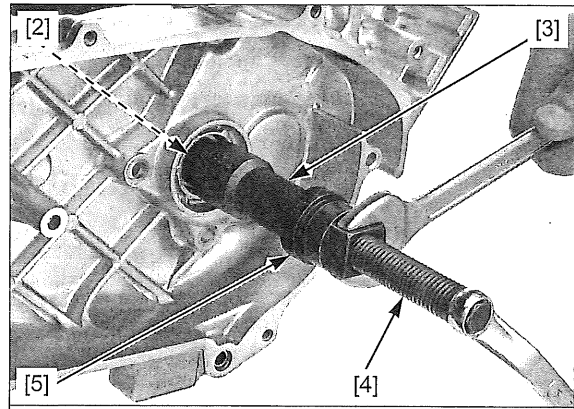

Apply engine oil to a new driveshaft oil seal [1] lip.

*Do not insert the oil seal too far.* Install the driveshaft oil seal so that the depth from the left crankcase surface is 0.2 - 0.8 mm (0.01 - 0.03 in), using the special tools.

**TOOLS:**

[2] Assembly shaft	07965-1660200
[3] Assembly collar	07965-GM00100
[4] Assembly collar attachment	07965-GM00200

Assemble the final reduction case (page 13-12).

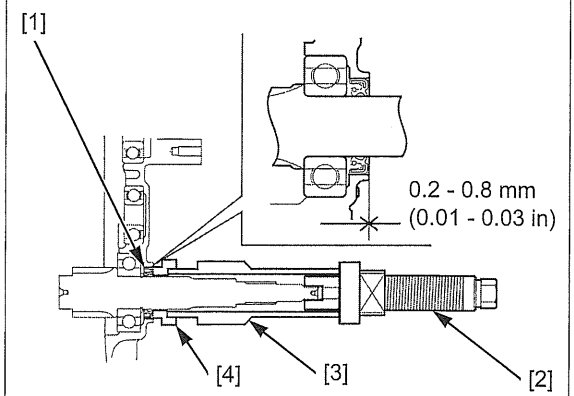
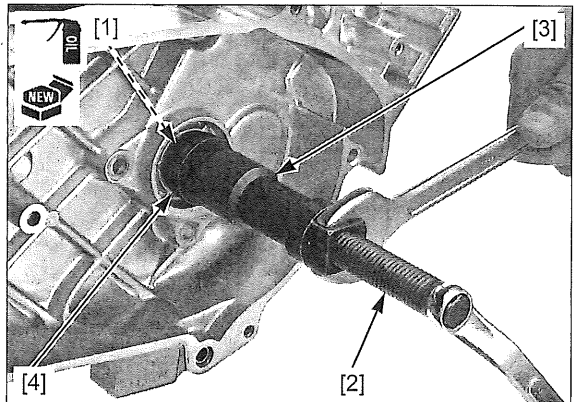

**FINAL REDUCTION CASE**

Separate the final reduction case (page 13-6).

Remove the driveshaft bearing [1] and countershaft bearing [2] using the special tools.

**TOOLS:**

**Driveshaft bearing:**

- [3] Bearing remover head, 15 mm 07936-KC10200
- [4] Bearing remover shaft, 15 mm 07936-KC10100
- [5] Remover weight 07741-0010201

**Countershaft bearing:**

- Bearing remover head, 12 mm 07936-1660110
- Bearing remover shaft, 12 mm 07936-1660120
- Remover weight 07741-0010201

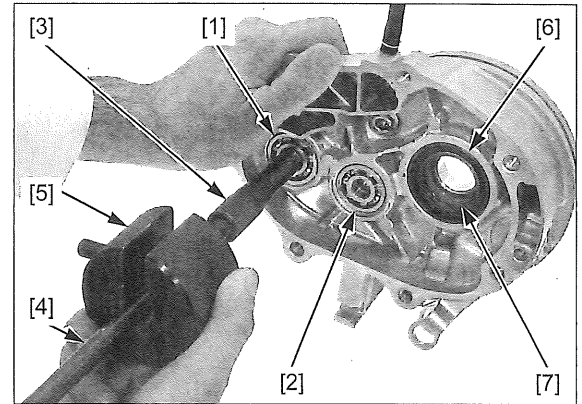

**U.S.A. TOOLS:**

**Driveshaft bearing:**

- Bearing remover, 15 mm 07936-KC10500
- Remover weight 07936-371020A

**Countershaft bearing:**

- Bearing remover, 12 mm 07936-166010A
- Remover handle 07936-3710100
- Remover weight 07936-371020A

Remove the final gear shaft oil seal [6] and bearing [7].

Apply engine oil to the driveshaft bearing [1] and countershaft bearing [2] cavity.

*Set the bearings with their marked sides facing up.*

Drive a new countershaft bearing and driveshaft bearing into the final reduction case squarely until they are fully seated, using the special tools.

**TOOLS:**

**Driveshaft bearing:**

- [3] Driver 07749-0010000
- [4] Attachment, 32 x 35 mm 07746-0010100
- [5] Pilot, 15 mm 07746-0040300

**Countershaft bearing:**

- Driver 07749-0010000
- Attachment, 32 x 35 mm 07746-0010100
- Pilot, 12 mm 07746-0040200

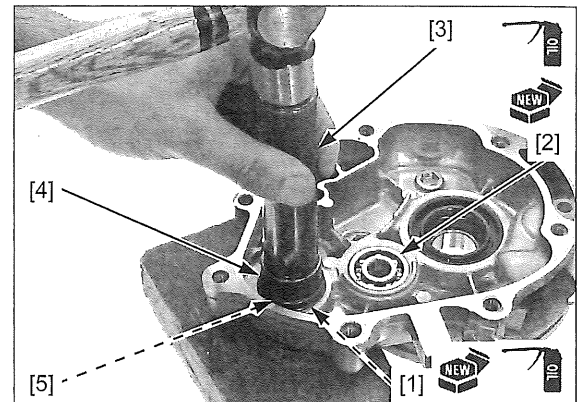

Apply engine oil to the final gear shaft bearing [1] cavity.

*Set the bearing with its marked side facing up.*

Drive a new final gear shaft bearing into the final reduction case squarely until it is fully seated, using the special tools.

**TOOLS:**

- [2] Driver 07749-0010000
- [3] Attachment, 51.5 mm 07946-3290000
- [4] Pilot, 25 mm 07746-0040600

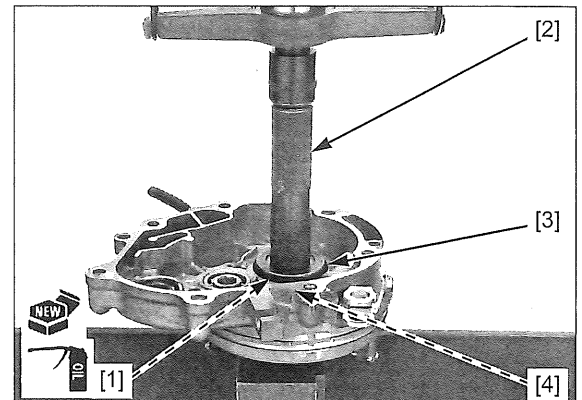

## FINAL REDUCTION

Apply engine oil to a new final gear shaft oil seal [1] lip.

*Do not insert the oil seal too far.*

Install the oil seal with the flat side facing the rear wheel side so that the depth from the final reduction case surface is 1.0 - 1.4 mm (0.04 - 0.06 in) using the special tools.

### TOOLS:

[2] Driver 07749-0010000

[3] Attachment, 51.5 mm 07946-3290000

Assemble the final reduction case (page 13-12).

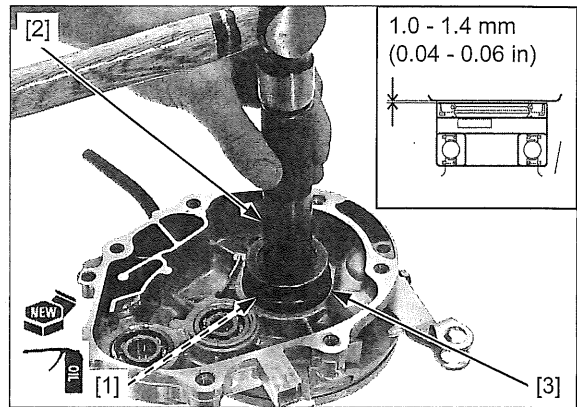

## FINAL REDUCTION CASE ASSEMBLY

Apply engine oil to each gear tooth and each bearing sliding area of shaft.

Install the final gear shaft [1].

Install the countershaft [2] into the counter gear [3] while aligning the countershaft splines with the counter gear splines and install them to the left crankcase.

Install the dowel pins [4] and a new gasket [5].

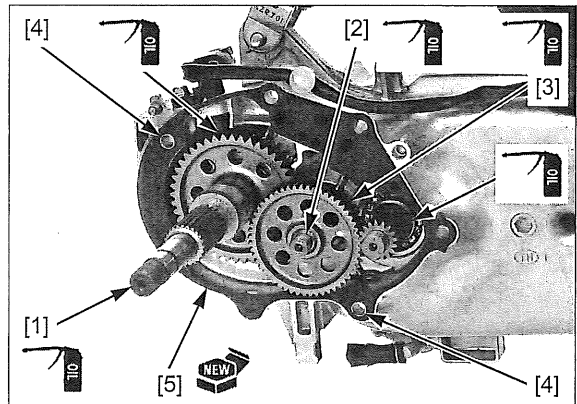

Set the rear brake cable [1] in position.

Install the final reduction case [2], case bolts [3], drain bolt [4] and a new sealing washer [5].

Tighten the final reduction case bolts and drain bolt in a crisscross pattern to the specified torque.

**TORQUE: 23 N·m (2.3 kgf·m, 17 lbf·ft)**

Install the following:

- VS sensor protector (page 21-16)
- Rear brake shoes (page 18-10)
- Rear wheel (page 18-6)
- Clutch/driven pulley (page 12-20)

Fill the final reduction case with the recommended oil (page 3-16).

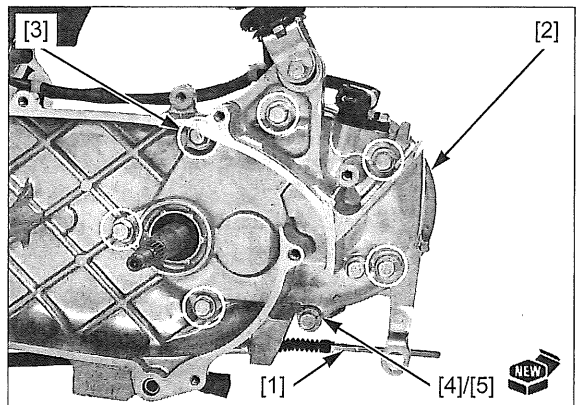



# 14. ALTERNATOR/STARTER

---

COMPONENT LOCATION..... 14-2

ALTERNATOR/STARTER ..... 14-4

SERVICE INFORMATION..... 14-3

# ALTERNATOR/STARTER

## COMPONENT LOCATION

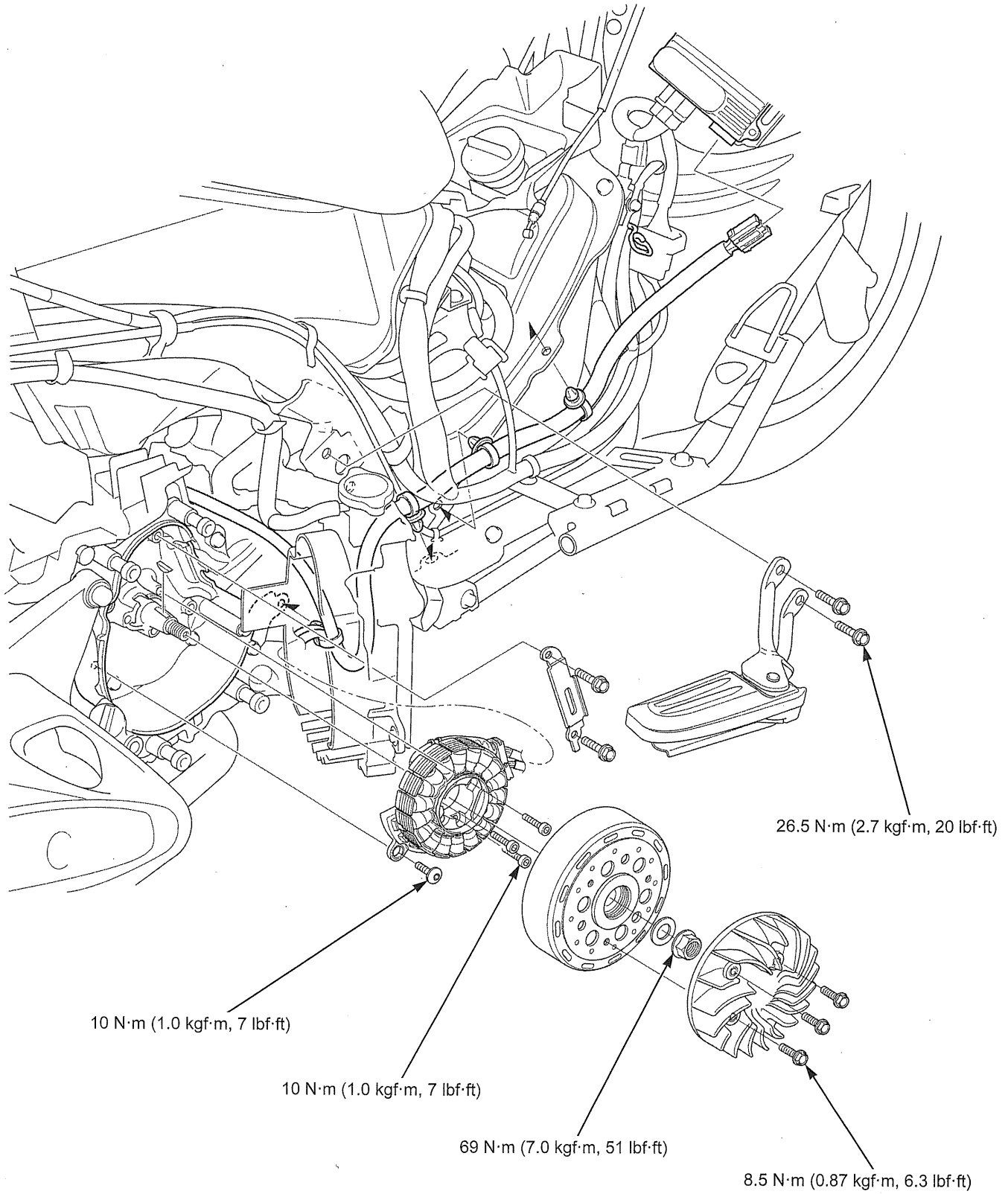

## SERVICE INFORMATION

### GENERAL

- Always turn the ignition switch OFF before servicing the alternator/starter. The alternator/starter could suddenly start when the ignition switch is turned ON, causing serious injury.
- This section covers the removal and installation of the flywheel and alternator/starter. These services can be done with the engine installed in the frame.
- For charging system inspection (page 20-8).
- For starter system inspection (page 6-11).

### TORQUE VALUES

ITEM	Q'TY	THREAD DIA. (mm)	TORQUE N·m (kgf·m, lbf·ft)	REMARKS
Stator mounting socket bolt	3	6	10 (1.0, 7)	
CKP sensor mounting special bolt	1	6	10 (1.0, 7)	
Flywheel nut	1	12	69 (7.0, 51)	
Cooling fan mounting bolt	3	6	8.5 (0.87, 6.3)	
Passenger step mounting bolt	4	8	26.5 (2.7, 20)	

### TOOLS

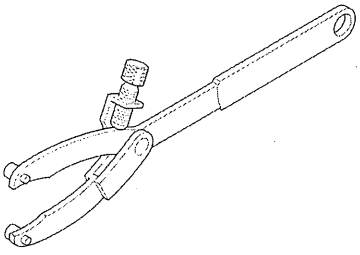
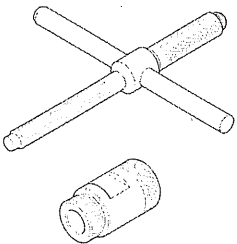
<p>Clutch center holder 07725-0030000</p> 	<p>Flywheel puller 07733-0010000</p>  <p>or 07933-0010000 (U.S.A. only)</p>
--	---

## ALTERNATOR/STARTER

### ALTERNATOR/STARTER

#### REMOVAL

Remove the right floor step (page 2-19).

Remove the mounting bolts [1] and right passenger step [2].

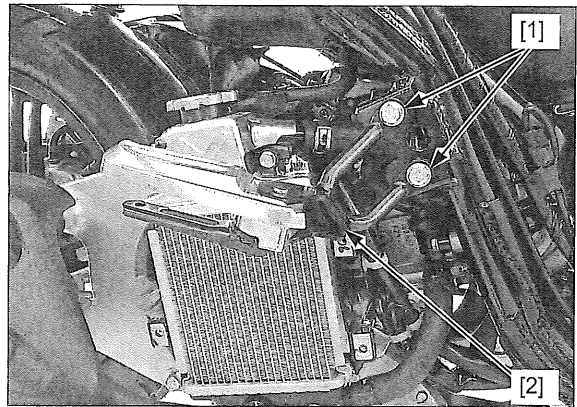

Disconnect the ECM 3P (Black) connector [1].

Release the engine sub harness [2] from the frame clamp [3].

Release the two wire band bosses [4].

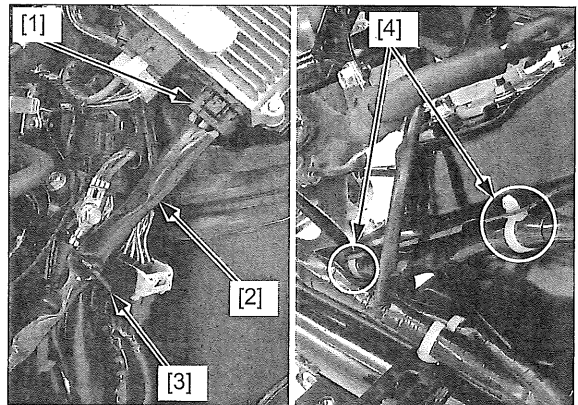

Release the three wire band bosses [1].

Disconnect the CKP sensor 6P (Black) connector [2].

*It is not necessary to disconnect the water hoses from the radiator.*

Remove the four radiator mounting bolts and move the radiator so that the cooling fan is accessible (page 9-7).

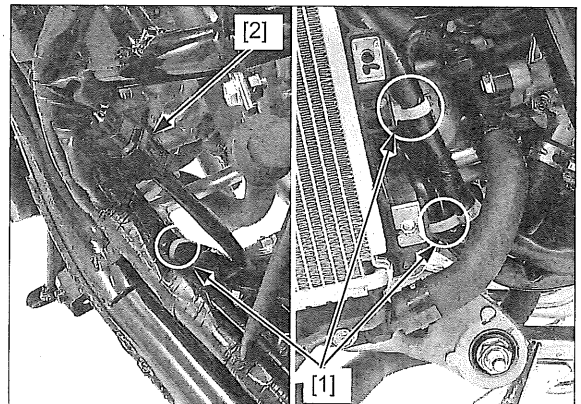

Remove the three bolts [1] and cooling fan [2].

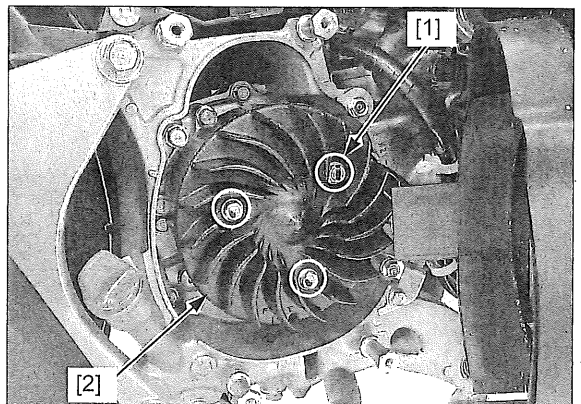

Hold the flywheel with the special tool and loosen the flywheel nut [1].

**TOOL:**  
 [2] Clutch center holder 07725-0030000

Remove the flywheel nut and washer [3].

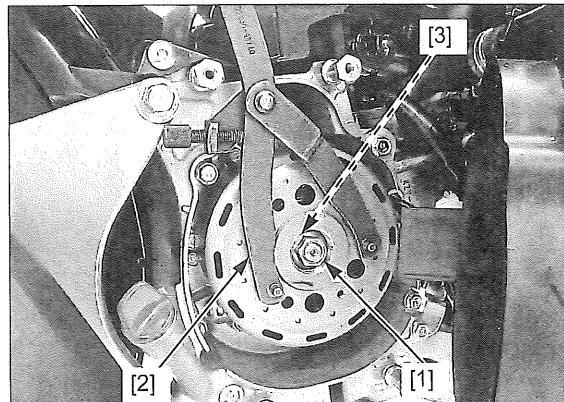

Remove the flywheel [1] using the special tool.

**TOOL:**  
 [2] Flywheel puller 07733-0010000 or 07933-0010000 (U.S.A. only)

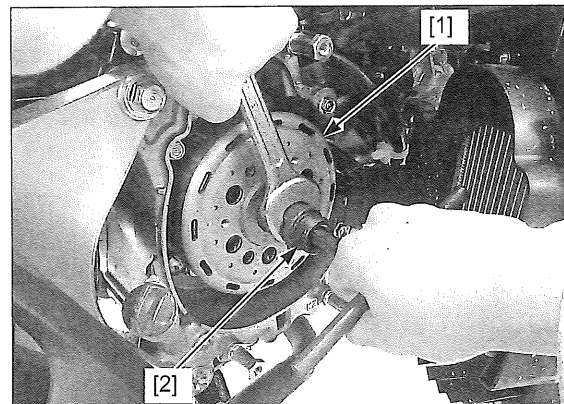

Remove the two bolts [1] and wire holder plate [2]. Release the grommets [3] from the right crankcase groove.

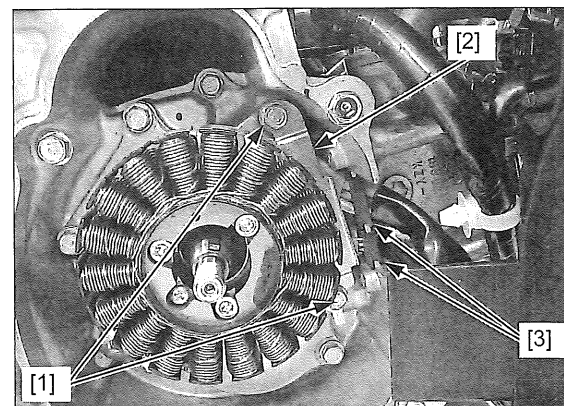

*Do not forget to remove the special bolt.* Remove the three mounting socket bolts [1], CKP sensor mounting special bolt [2] and stator [3] from the stator base.

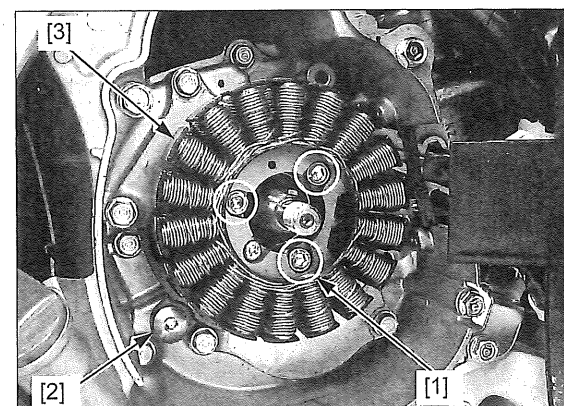

## ALTERNATOR/STARTER

Be careful not to damage the key and groove.  
Remove the woodruff key [1].

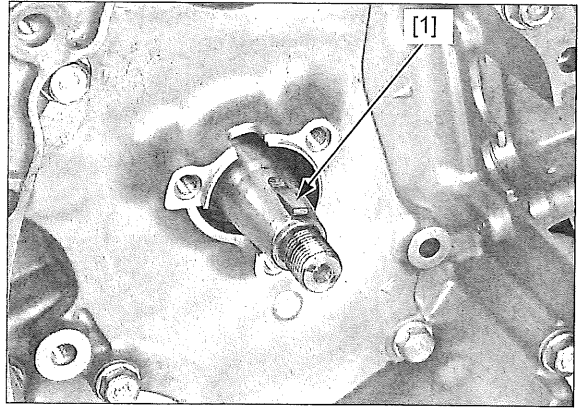

### INSTALLATION

Install the woodruff key [1] into the crankshaft key groove.

Clean any oil and grease from the crankshaft.

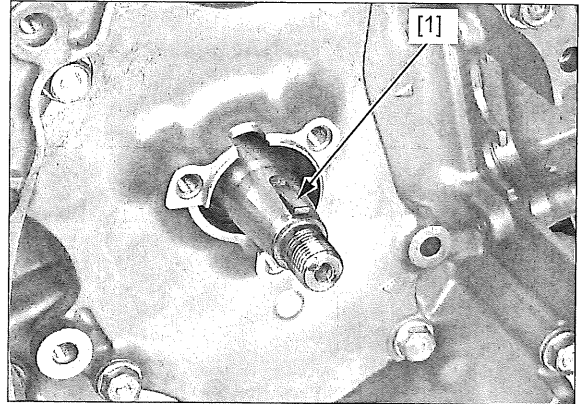

Set the stator assembly [1] onto the stator base.  
Install and tighten the stator mounting socket bolts [2]  
and CKP sensor mounting special bolt [3] to the  
specified torque.

**TORQUE: 10 N·m (1.0 kgf·m, 7 lbf·ft)**

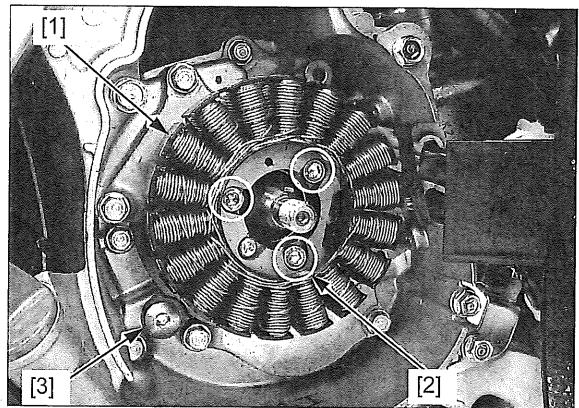

Route the wire properly and set the wire grommets [1]  
into the right crankcase grooves.

Set the wire holder plate [2] as shown and tighten the  
holder plate bolts [3].

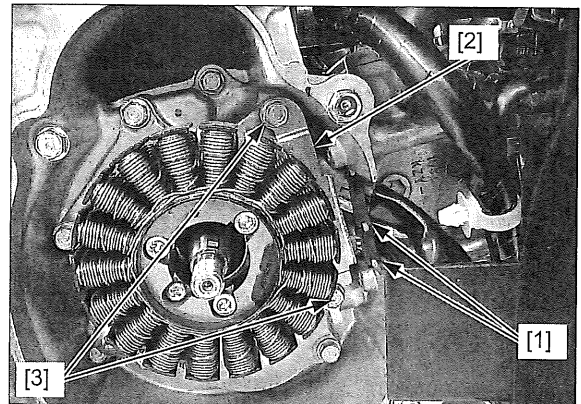

## ALTERNATOR/STARTER

Install the flywheel [1] onto the crankshaft by aligning the key way on the flywheel with the woodruff key.

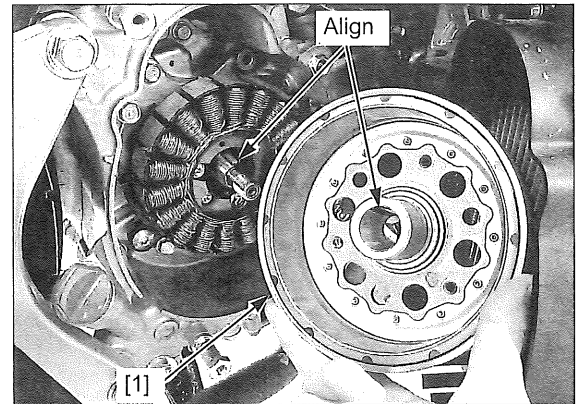

Install the flywheel washer [1] and nut [2].

Hold the flywheel with the special tool and tighten the nut to the specified torque.

**TOOL:**

**[3] Clutch center holder**                      07725-0030000

**TORQUE: 69 N·m (7.0 kgf·m, 51 lbf·ft)**

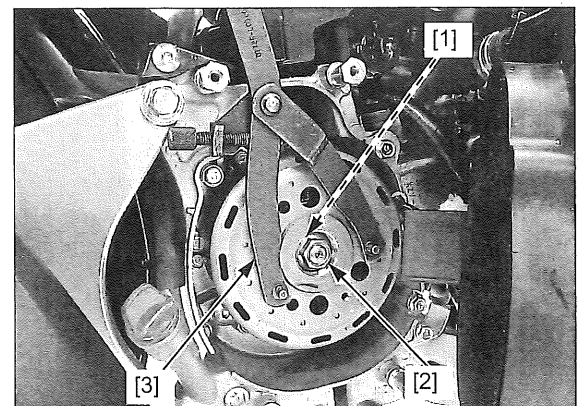

Install the cooling fan [1] while aligning its boss with the hole on the flywheel.

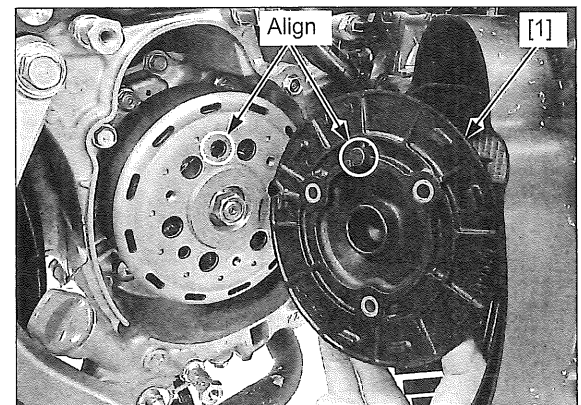

Install the cooling fan mounting bolts [1] and tighten them to the specified torque.

**TORQUE: 8.5 N·m (0.87 kgf·m, 6.3 lbf·ft)**

Install the radiator back in position (page 9-7).

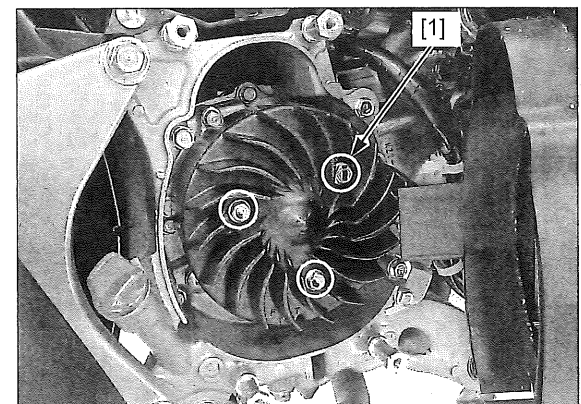



## ALTERNATOR/STARTER

Install the three wire band bosses [1].

Connect the CKP sensor 6P (Black) connector [2].

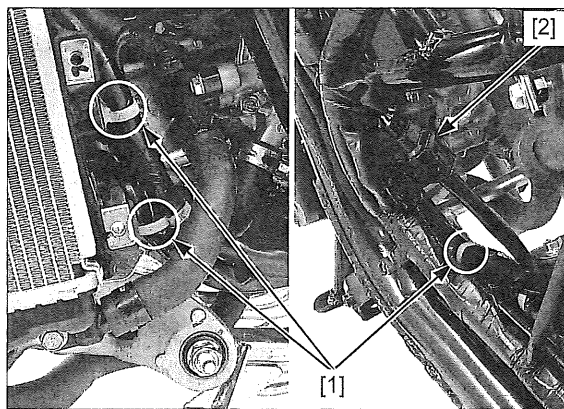

Install the two wire band bosses [1] and secure the engine sub harness [2] into the frame clamp [3].

Connect the ECM 3P (Black) connector [4].

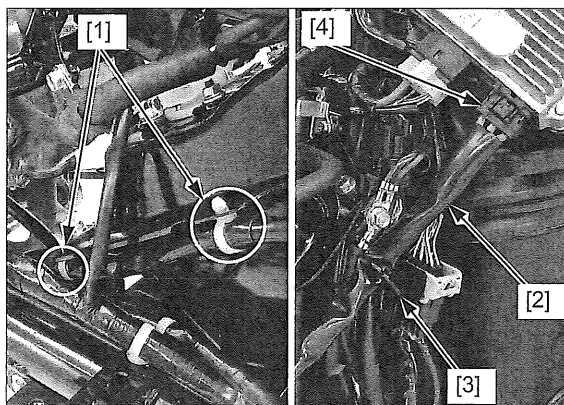

Set the right passenger step [1], then install and tighten the mounting bolts [2] to the specified torque.

**TORQUE: 26.5 N·m (2.7 kgf·m, 20 lbf·ft)**

Install the right floor step (page 2-19).

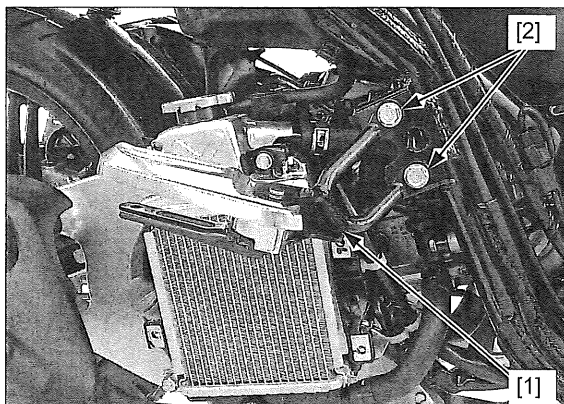



# 15. CRANKCASE/CRANKSHAFT

---

COMPONENT LOCATION .....	15-2	CRANKCASE SEPARATION .....	15-5
SERVICE INFORMATION .....	15-3	CRANKSHAFT INSPECTION .....	15-7
TROUBLESHOOTING .....	15-4	CRANKCASE ASSEMBLY .....	15-8

**CRANKCASE/CRANKSHAFT**  
**COMPONENT LOCATION**

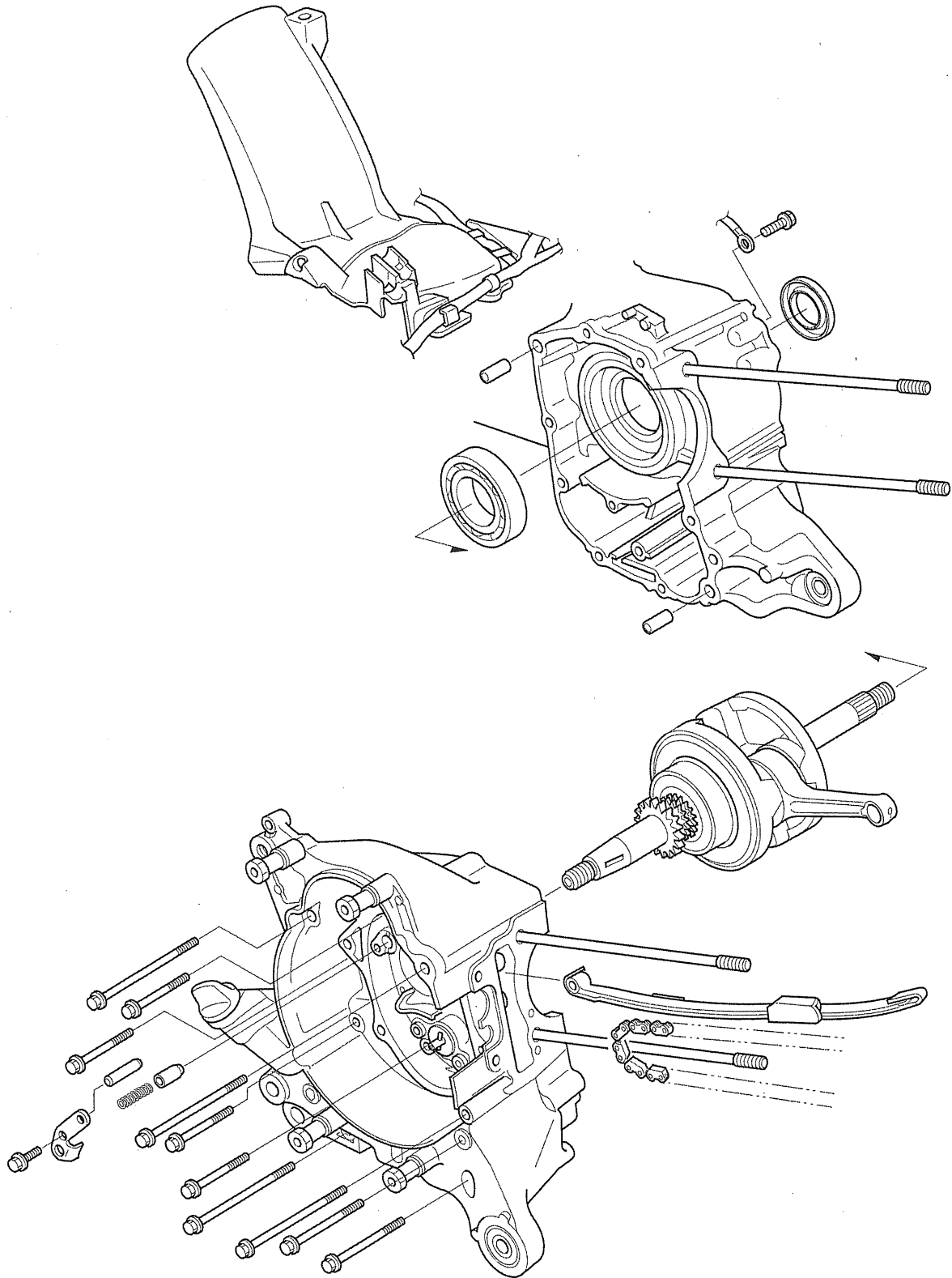

## SERVICE INFORMATION

### GENERAL

- This section covers the crankcase separation to service the crankshaft.
- The following parts must be removed before separating the crankcase.
  - Centerstand (page 2-28)
  - Engine (page 16-4)
  - Cylinder head (page 10-13)
  - Cylinder (page 11-5)
  - Piston (page 11-7)
  - Drive pulley (page 12-9)
  - Clutch/driven pulley (page 12-12)
  - Flywheel/starter (page 14-4)
  - Stator base (page 8-5)
  - Oil pump driven gear (page 8-5)
- In addition to the parts listed above, remove the following parts when the left crankcase must be replaced.
  - Final reduction (page 13-6)
- In addition to the parts listed above, remove the following parts when the right crankcase must be replaced.
  - Oil pump (page 8-5)
- Be careful not to damage the crankcase mating surfaces when separating and assembling the crankcase halves.
- Clean all disassembled parts with clean solvent and dry them using compressed air before inspection.
- When installing the crankshaft, be sure to use the special tools; position the special tools on the bearing inner race and pull the crankshaft into the bearing until it is fully seated.

### SPECIFICATIONS

		Unit: mm (in)	
	ITEM	STANDARD	SERVICE LIMIT
Crankshaft	Connecting rod side clearance	0.10 – 0.35 (0.004 – 0.014)	0.55 (0.022)
	Connecting rod radial clearance	0.004 – 0.016 (0.0002 – 0.0006)	0.05 (0.002)
	Runout	–	0.10 (0.004)

# CRANKCASE/CRANKSHAFT

## TOOLS

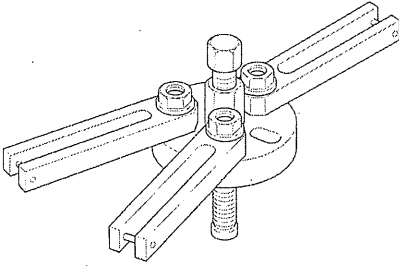
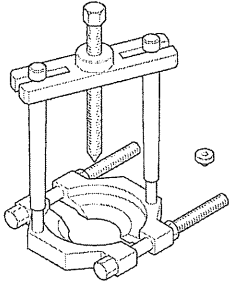
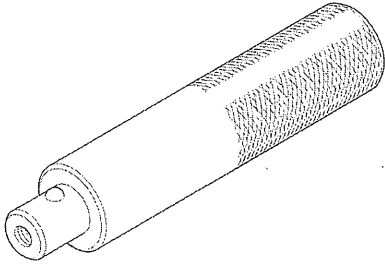
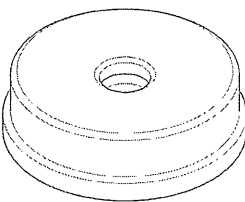
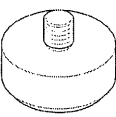
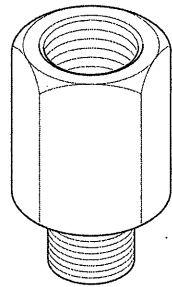
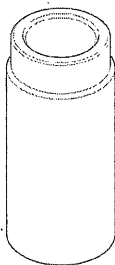
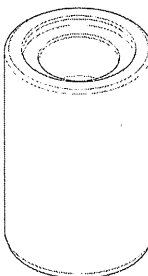
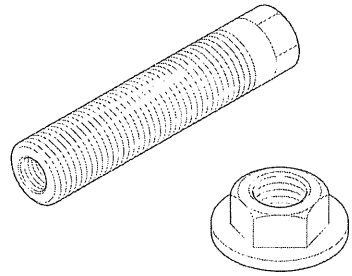
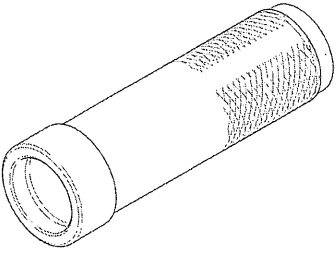
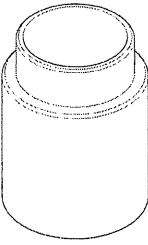
<p>Case puller 07SMC-0010001</p>  A mechanical case puller consisting of two long parallel bars connected by a central bracket with several adjustment screws.	<p>Universal bearing puller 07631-0010000</p>  A universal bearing puller with a central threaded rod, a base plate, and two vertical support arms with adjustable clamps. <p>or equivalent commercially available in U.S.A.</p>	<p>Driver 07749-0010000</p>  A long, cylindrical driver tool with a textured grip section in the middle and a smooth section at the end.
<p>Attachment, 72 x 75 mm 07746-0010600</p>  A circular metal attachment with a central hole and a raised outer rim.	<p>Pilot, 35 mm 07746-0040800</p>  A small, circular metal pilot with a central hole.	<p>Assembly shaft adaptor 07WMF-KFF0200</p>  A hexagonal shaft adaptor with a threaded end and a smooth end.
<p>Assembly collar A 07965-VM00100</p>  A cylindrical assembly collar with a smooth outer surface and a slightly raised top edge.	<p>Assembly collar B 07931-KF00100</p>  A cylindrical assembly collar with a smooth outer surface and a slightly raised top edge.	<p>Assembly shaft 07965-VM00200</p>  A threaded assembly shaft with a hexagonal nut and a washer.
<p>Driver, 40 mm 07746-0030100</p>  A cylindrical driver tool with a textured grip section and a smooth section at the end.	<p>Driver attachment, 35 mm 07HMD-MR70100</p>  A cylindrical driver attachment with a smooth outer surface and a slightly raised top edge.	

## TROUBLESHOOTING

### Abnormal noise

- Worn crankshaft bearing
- Worn connecting rod big end bearing
- Worn connecting rod small end (page 11-8)

## CRANKCASE SEPARATION

Refer to service information (page 15-3) for the parts which must be removed before separating the crankcase.

Remove the bolt [1] and stay [2].

Remove the bolt [3] and ground cable [4].

Remove the rear inner fender [5] from the crankcase.

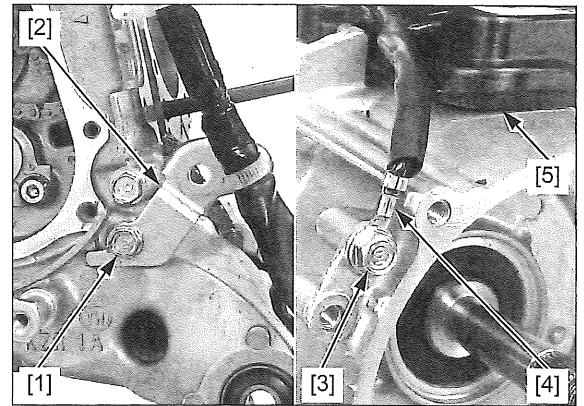

Remove the bolt [1] and set plate [2].

Remove the pivot [3] and cam chain tensioner slider [4].

Remove the spring [5] and plunger [6] from the right crankcase.

Remove the cam chain [7] from the crankshaft.

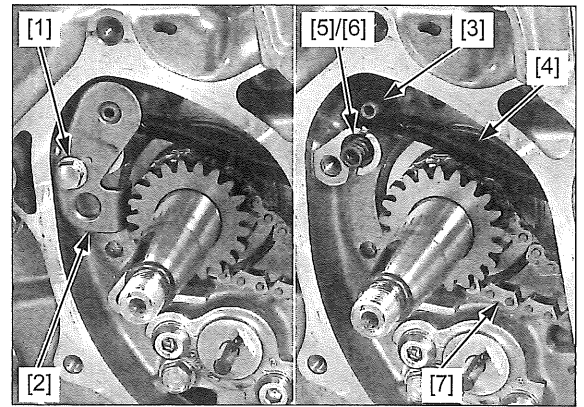

Remove the crankcase bolts [1] from the right crankcase.

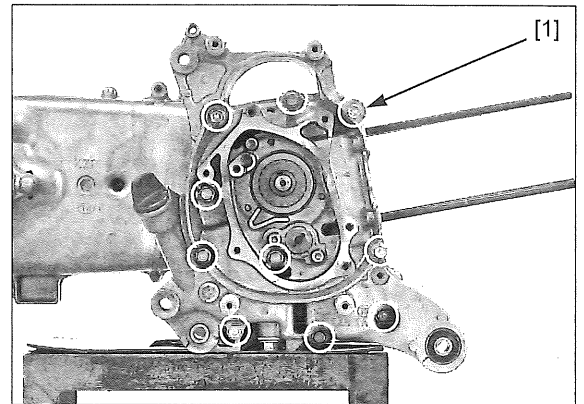

*Be careful not to damage the crankcase mating surface.* Place the crankcase with the left crankcase [1] facing down and separate the left and right [2] crankcase.

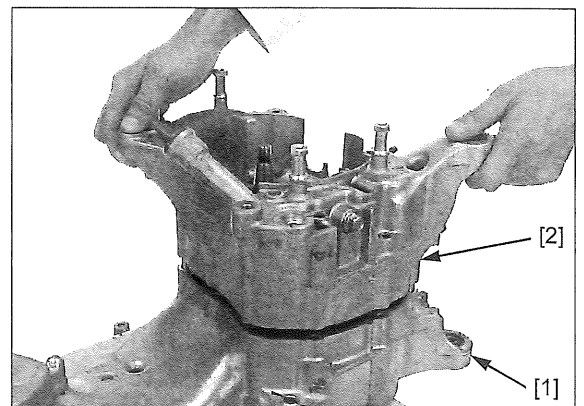

## CRANKCASE/CRANKSHAFT

Remove the dowel pins [1] from the left crankcase.

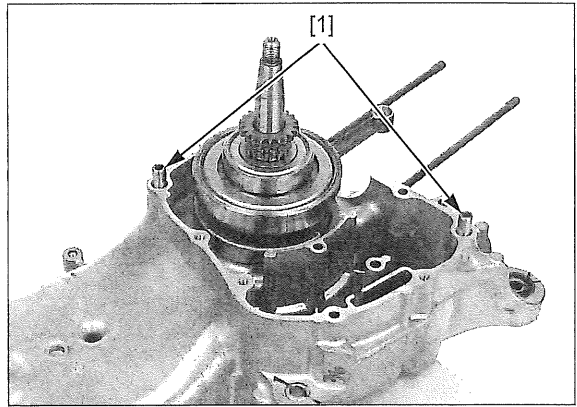

Remove the crankshaft [1] from the left crankcase using the special tool.

**TOOL:**

[2] Case puller

07SMC-0010001

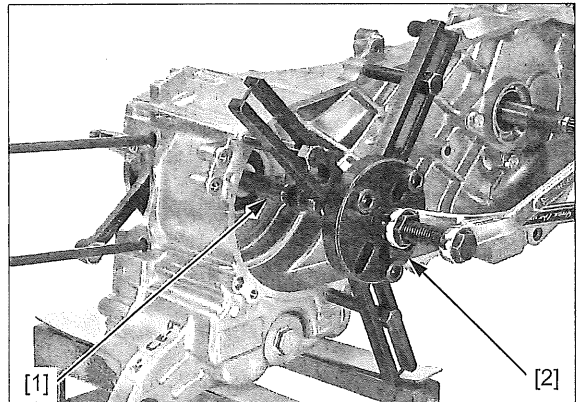

Remove the left crankshaft bearing [1] using the special tool.

**TOOL:**

[2] Universal bearing puller

07631-0010000 or  
equivalent  
commercially  
available in U.S.A.

– If the left crankshaft bearing remains in the crankcase, drive it out to the right side.

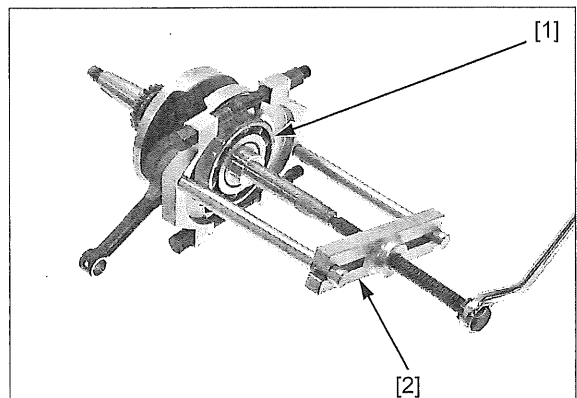

If the left crankshaft bearing remains in the crankcase:

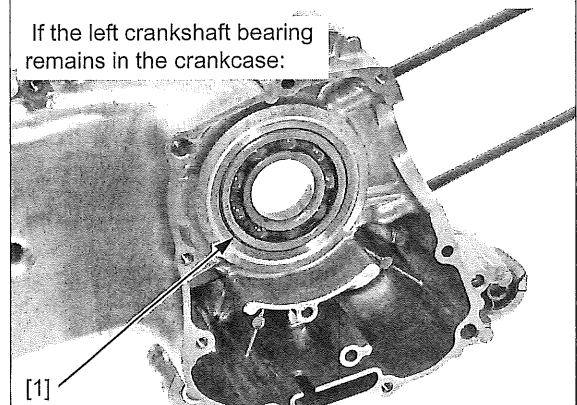

Remove the oil seal [1] from the left crankcase.

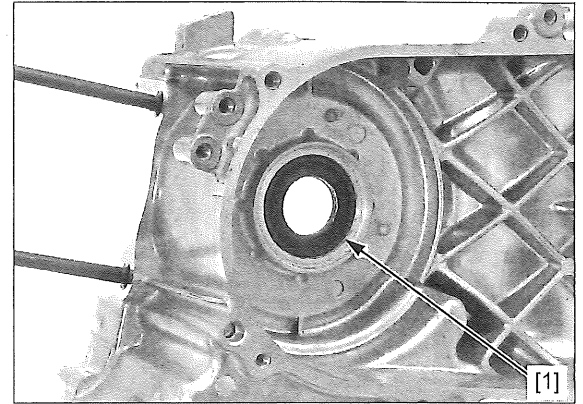

## CRANKSHAFT INSPECTION

Remove the crankshaft (page 15-5).

Turn the outer race of the right crankshaft bearing [1] with your finger. The bearing should turn smoothly and quietly. Also check that the bearing inner race fits tightly on the right crankshaft.

Replace the crankshaft as an assembly if the bearing does not turn smoothly, quietly, or if it fits loosely on the right crankshaft.

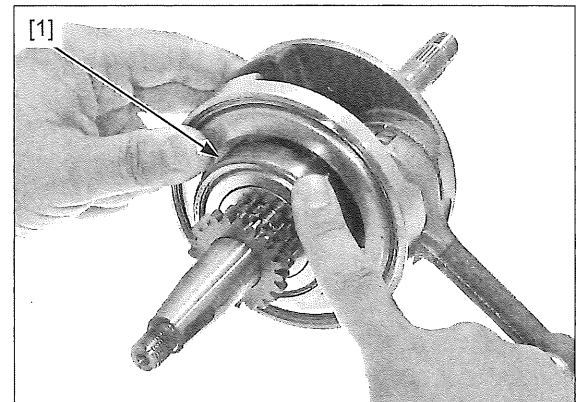

*If the timing sprocket teeth are worn or damaged, check the cam chain, tensioner, and cam sprocket.*

Check the oil pump drive gear [1] and timing sprocket [2] teeth for wear or damage.

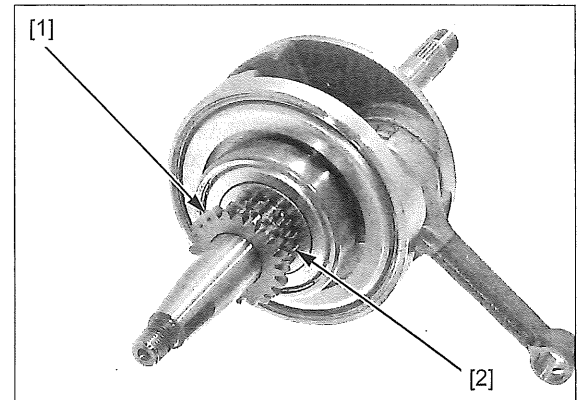

Measure the connecting rod big end side clearance with a feeler gauge [1].

**SERVICE LIMIT: 0.55 mm (0.022 in)**

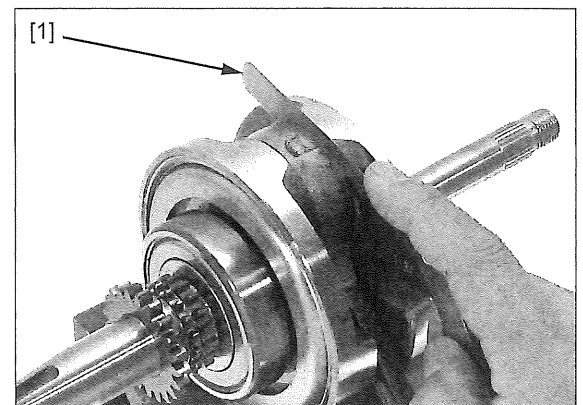

## CRANKCASE/CRANKSHAFT

Set the crankshaft on V-blocks and measure the connecting rod big end radial clearance.

**SERVICE LIMIT: 0.05 mm (0.002 in)**

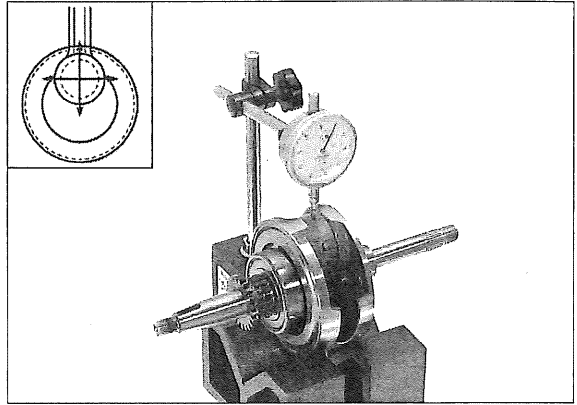

Set the crankshaft on V-blocks and measure the runout using a dial indicator. Actual runout is 1/2 of total indicator reading.

**SERVICE LIMIT: 0.10 mm (0.004 in)**

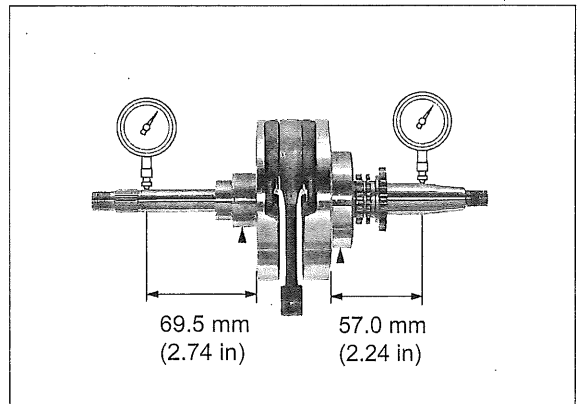

## CAM CHAIN TENSIONER SLIDER INSPECTION

Check the cam chain tensioner slider [1] for excessive wear or damage. Replace if necessary.

If the cam chain tensioner slider is worn or damaged, also check the condition of cam chain guide.

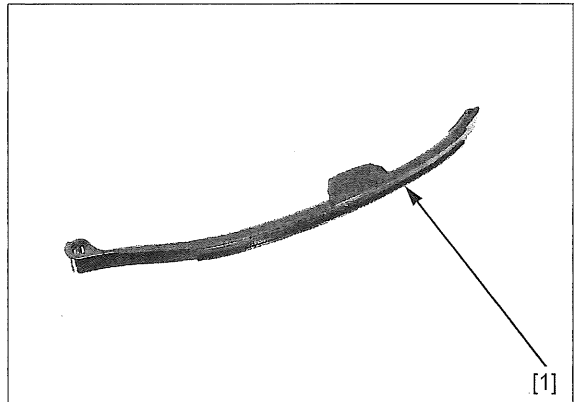

## CRANKCASE ASSEMBLY

*Be careful not to damage the crankcase mating surface.* Clean the insides and mating surface [1] of the crankcases. Check for cracks or other damage. Remove any roughness or irregularities with an oil stone.

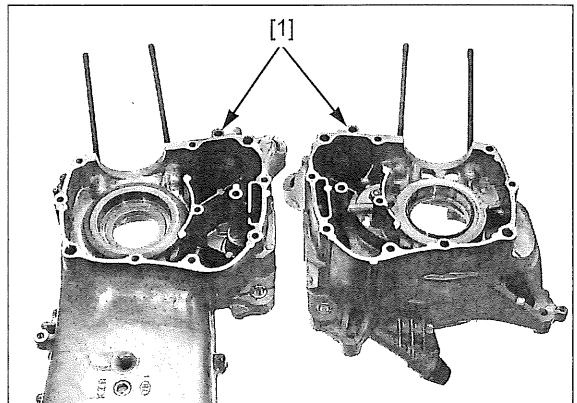



## CRANKCASE/CRANKSHAFT

Apply engine oil to the bearing cavity.

Drive the left crankshaft bearing [1] into the left crankcase squarely until it is fully seated, using the special tool.

**TOOLS:**

[2] Driver	07749-0010000
[3] Attachment, 72 x 75 mm	07746-0010600
[4] Pilot, 35 mm	07746-0040800

Apply 2 cm<sup>3</sup> minimum of engine oil to a new left crankshaft bearing.

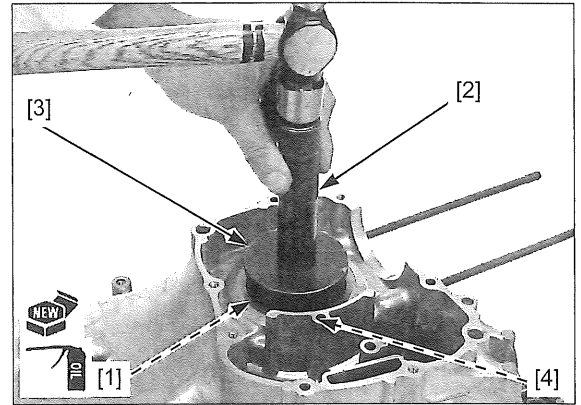

Install the crankshaft into the left crankshaft bearing as follows:

Install the assembly shaft adaptor [1] to the left crankshaft.

Position the assembly collar A [2] on the left crankshaft bearing inner race and set the assembly collar B [3] to the assembly collar A.

Install the assembly shaft [4] to the assembly collar B and screw it onto the assembly shaft adaptor while aligning the center of the assembly collar B with the assembly shaft.

**NOTE:**

When pulling the crankshaft into the bearing, be careful not to damage the connecting rod [5].

Pull the crankshaft into the bearing until it is fully seated while positioning the connecting rod in the cylinder sleeve opening on the left crankcase.

**TOOLS:**

[1] Assembly shaft adaptor	07WMF-KFF0200
[2] Assembly collar A	07965-VM00100
[3] Assembly collar B	07931-KF00100
[4] Assembly shaft	07965-VM00200

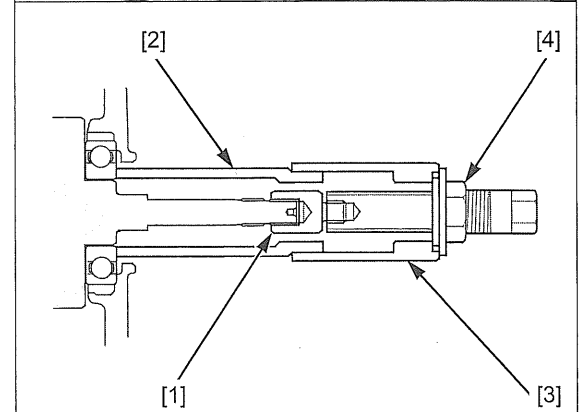
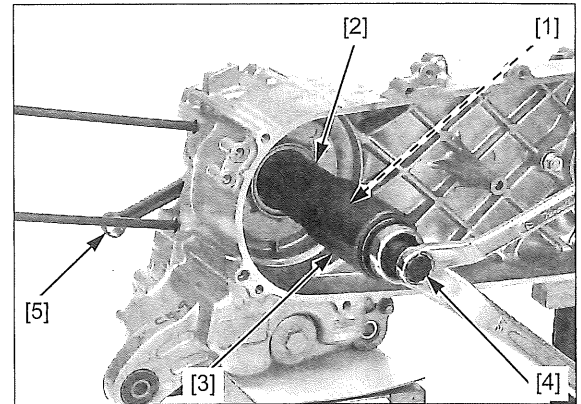

Apply engine oil to a new oil seal [1] lip.

*Do not insert the oil seal too far.* Install the oil seal to the left crankcase squarely so that the depth from the left crankcase surface is 0.4 - 1.0 mm (0.02 - 0.04 in), using the special tools.

**TOOLS:**

[2] Driver, 40 mm	07746-0030100
[3] Driver attachment, 35 mm	07HMD-MR70100

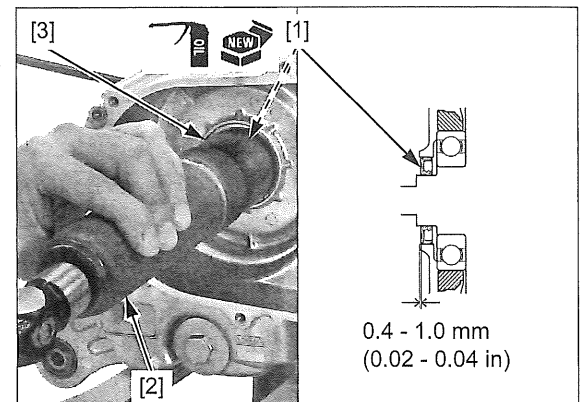

## CRANKCASE/CRANKSHAFT

Apply sealant (Three bond 1207B or Three bond 1215 or LOCTITE 5060S or 5020 or equivalent) to the right crankcase mating surface.

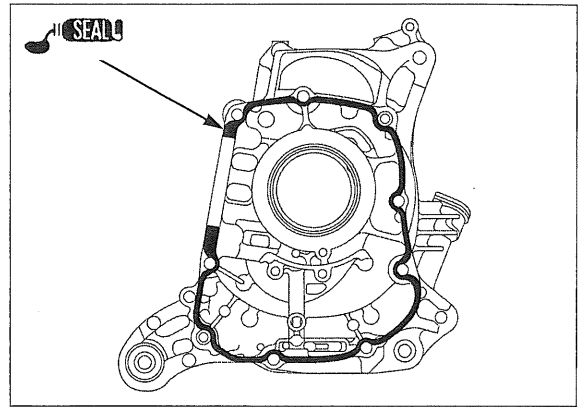

Inject minimum 3 cm<sup>3</sup> of engine oil to the connecting rod big end bearing [1].

Apply 2 cm<sup>3</sup> minimum of engine oil to right crankshaft bearing [2].

Install the dowel pins [3] to the left crankcase.

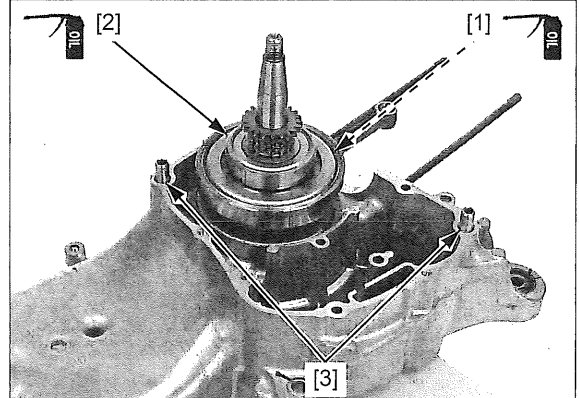

Assemble the left [1] and right [2] crankcase.

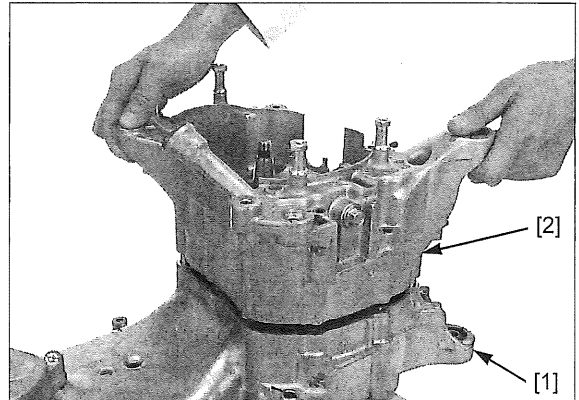

Install the crankcase bolts [1] and tighten them in a crisscross pattern in 2 - 3 steps.

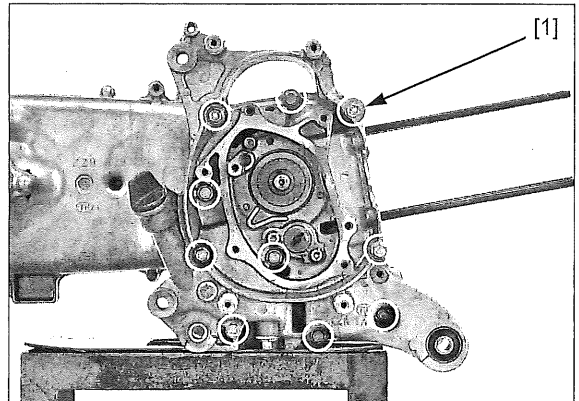

## CRANKCASE/CRANKSHAFT

Apply engine oil to the plunger [1] sliding surface and install the plunger and spring [2] into the right crankcase.

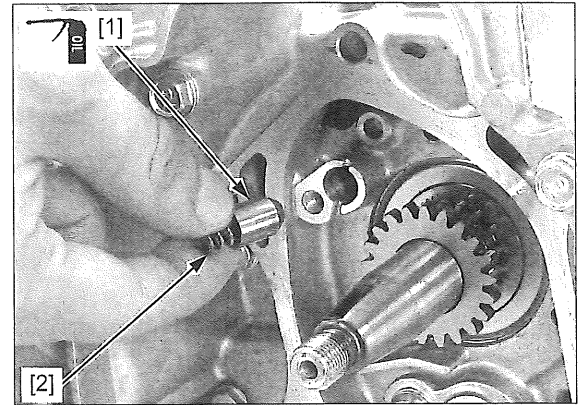

Apply engine oil to the timing sprocket teeth [1] and the entire cam chain [2] surface.

Install the cam chain to the timing sprocket.

Install the cam chain tensioner slider [3], pivot [4] and set plate [5].

Install and tighten the bolt [6].

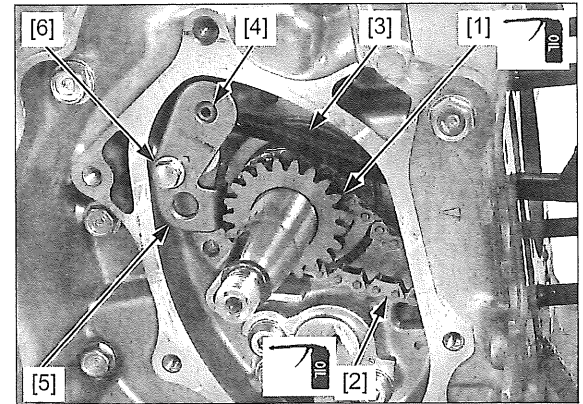

Install the rear inner fender [1] to the crankcase.

Set the ground cable [2] against the crankcase, then install and tighten the bolt [3].

Install the stay [4] and tighten the bolt [5].

Refer to service information (page 15-3) for installation of parts removed to perform crankcase service.

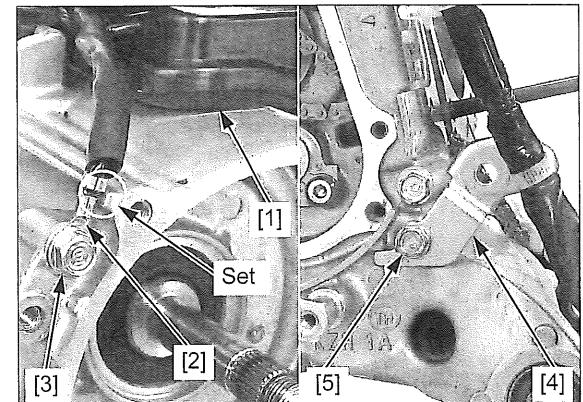

---

**MEMO**

---

# 16. ENGINE REMOVAL/INSTALLATION

---

COMPONENT LOCATION .....	16-2	ENGINE HANGER LINK.....	16-6
SERVICE INFORMATION.....	16-3	ENGINE INSTALLATION .....	16-7
ENGINE REMOVAL .....	16-4		

# ENGINE REMOVAL/INSTALLATION

## COMPONENT LOCATION

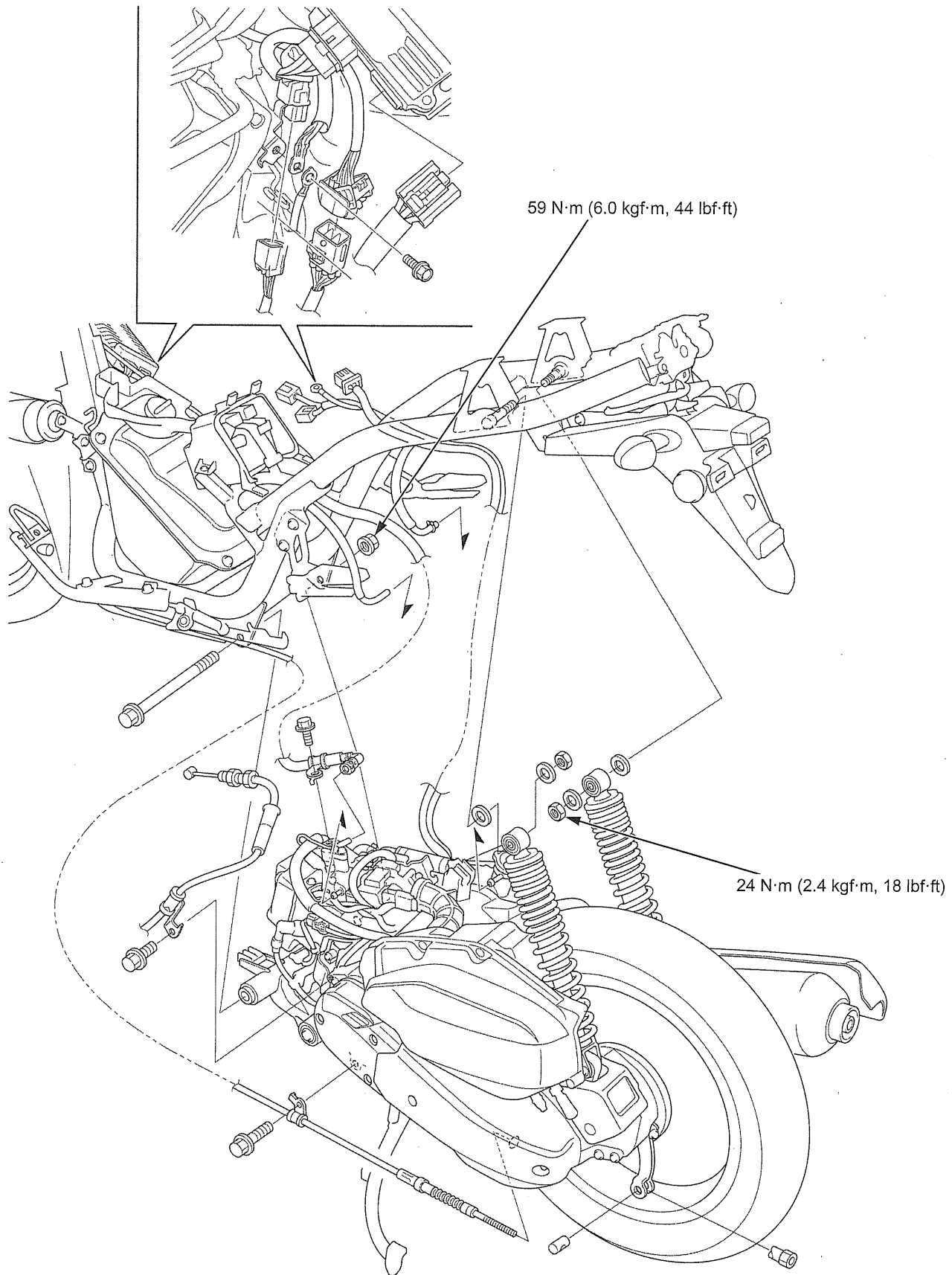

## SERVICE INFORMATION

### GENERAL

- Support the frame using a hoist to ease engine mounting bolt removal.
- When removing/installing the engine, tape the frame around the engine beforehand for frame protection.
- The following components require engine removal for service.
  - Cylinder head/valves (page 10-3)
  - Cylinder/piston (page 11-3)
  - Crankcase/crankshaft (page 15-3)
- The following components can be serviced with the engine installed in the frame.
  - Drive pulley/driven pulley/clutch (page 12-3)
  - Final reduction (page 13-3)
  - Alternator/starter (page 14-4)
  - Camshaft (page 10-8)
  - Water pump (page 9-8)
  - Throttle body (page 7-15)
  - Oil pump (page 8-5)

### SPECIFICATIONS

ITEM		SPECIFICATIONS
Engine dry weight		30.1 kg (66.4 lbs)
Coolant capacity	Radiator and engine	0.48 liter (0.51 US qt, 0.42 Imp qt)
Engine oil capacity	After draining	0.8 liter (0.8 US qt, 0.7 Imp qt)
	After disassembly	0.9 liter (1.0 US qt, 0.8 Imp qt)
	After oil strainer removal	0.9 liter (1.0 US qt, 0.8 Imp qt)

### TORQUE VALUES

ITEM	Q'TY	THREAD DIA. (mm)	TORQUE N·m (kgf·m, lbf·ft)	REMARKS
Engine hanger link pivot nut				
- Frame side	1	10	59 (6.0, 44)	U-nut
- Engine side	1	10	49 (5.0, 36)	U-nut
Shock absorber upper mounting nut	2	10	24 (2.4, 18)	

## ENGINE REMOVAL/INSTALLATION

### ENGINE REMOVAL

Place the scooter on its centerstand.

Remove the following:

- Floor step (page 2-19)
- Luggage box (page 2-25)

Relieve the fuel pressure and disconnect the fuel injector side quick connect fitting (page 7-6).

Remove the bolt [1] and cable clamp [2].

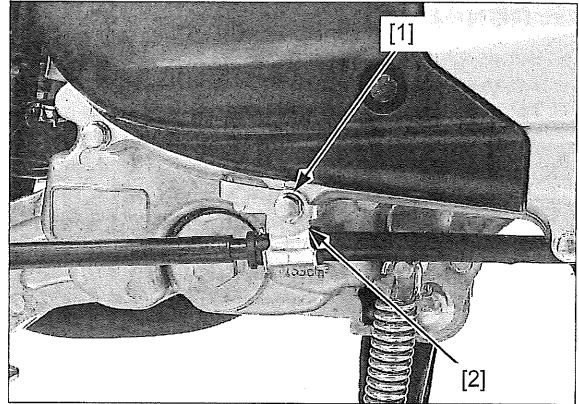

Remove the rear brake adjusting nut [1].  
Pull out the brake cable [2] from the joint pin [3] and cable holder [4].  
Remove the joint pin from the brake arm.

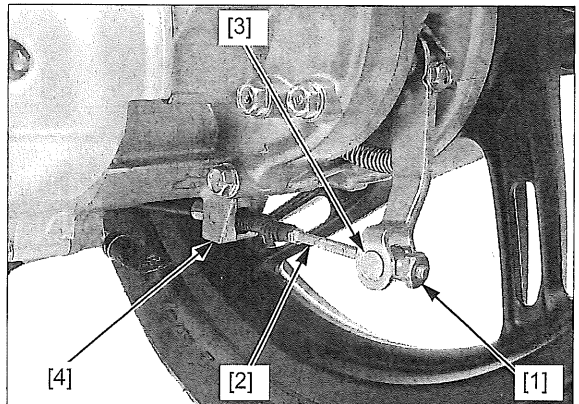

*EXCEPT After '13 model CM type:* Disconnect the EVAP canister-to-intake pipe hose [1] from the intake pipe joint and pull it out from the clamps [2].

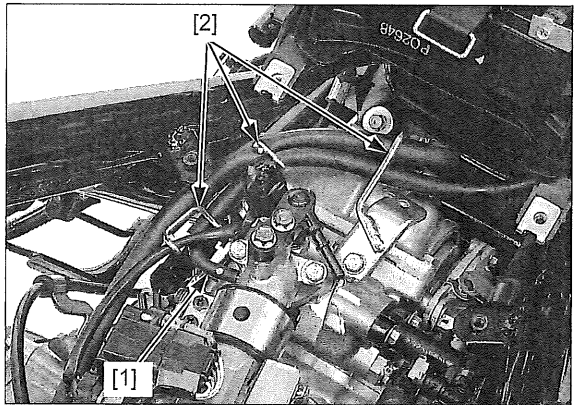

Loosen the throttle cable lock nut [1].  
Disconnect the throttle cable [2] from the cable bracket [3] and throttle drum [4].

Remove the bolt [5] and cable clamp [6].

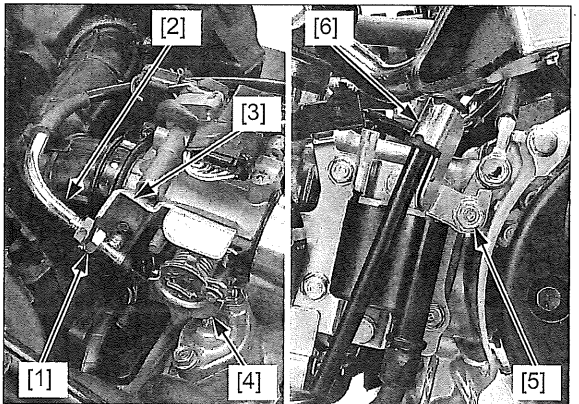



## ENGINE REMOVAL/INSTALLATION

Pinch the siphon hose [1] using a hose clamp [2] and disconnect the hose from the radiator.

Release the siphon hose from the hose guide [3].

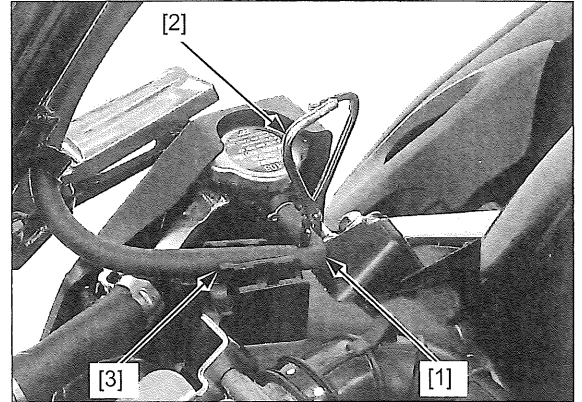

Disconnect the following:

- ECM 3P (Black) connector [1]
- Engine sub harness 10P connector [2]
- Engine sub harness 6P (Black) connector [3]

Release the engine sub harness [4] from the frame clamp [5].

Remove the bolt [6] and ground cables.

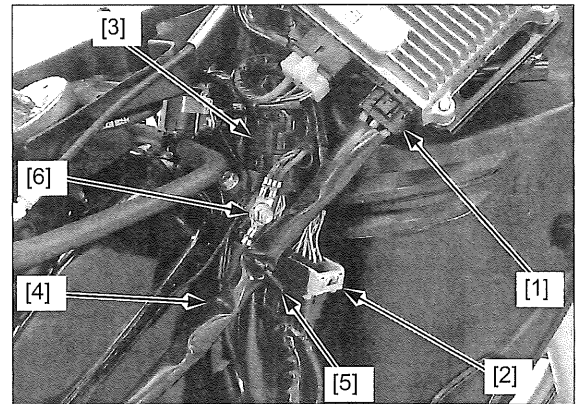

Release the four wire band bosses [1].

Disconnect the CKP sensor 6P (Black) connector [2].

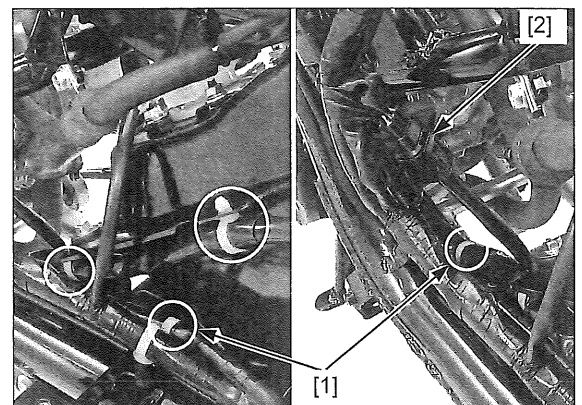

Support the frame in upright position.  
Hold the front wheel.

Remove the both rear shock absorber upper mounting nuts [1] and washers [2].

Release the both rear shock absorber upper mount from the frame.

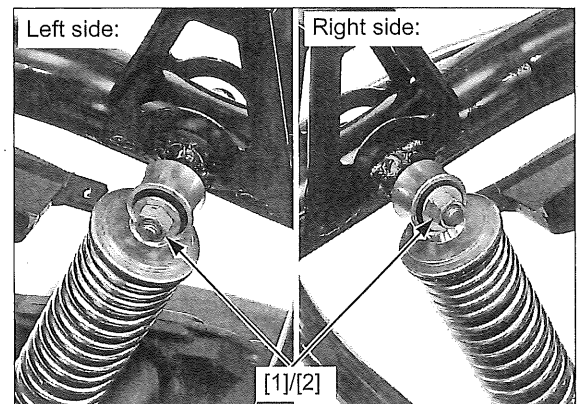

## ENGINE REMOVAL/INSTALLATION

Remove the engine hanger link nut [1] and pull out the bolt [2].

Slightly pull the engine straight back to release it from the frame and remove the engine, being careful not to damage the rear fender.

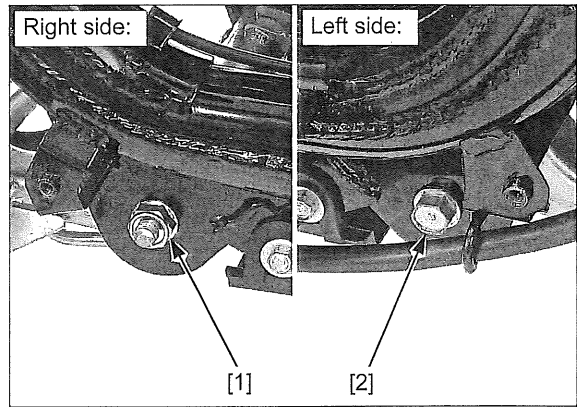

## ENGINE HANGER LINK

### REMOVAL/INSTALLATION

Remove the following:

- Engine (page 16-4)
- Exhaust pipe/muffler (page 2-28)

Remove the engine hanger link nut [1], bolt [2] and engine hanger link [3].

Install the engine hanger link, bolt and nut, then temporarily tighten the nut.

Install the removed parts in the reverse order of removal.

#### NOTE:

- After installing the engine to the frame, tighten the engine hanger link nut to the specified torque (page 16-7).

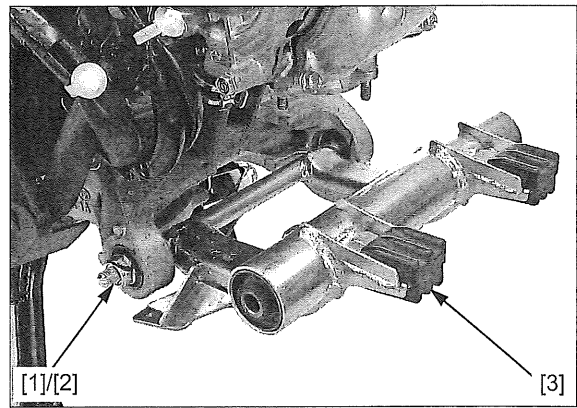

### INSPECTION

Check the hanger link bushings [1] and stopper rubbers [2] for wear or damage.

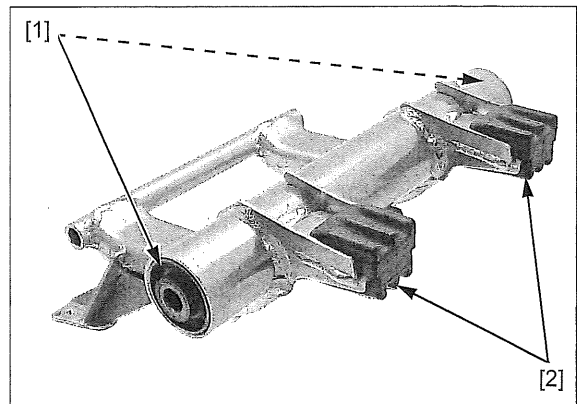

Check the engine mount bushings [1] for wear or damage.

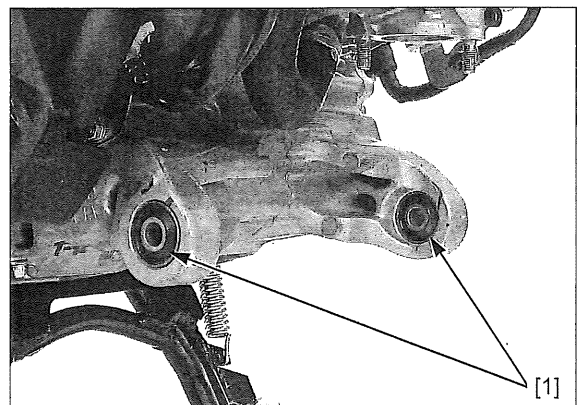

## ENGINE INSTALLATION

Support the frame in upright position.  
Hold the front wheel.

Set the engine to the frame by aligning the frame grooves and engine hanger link bosses.

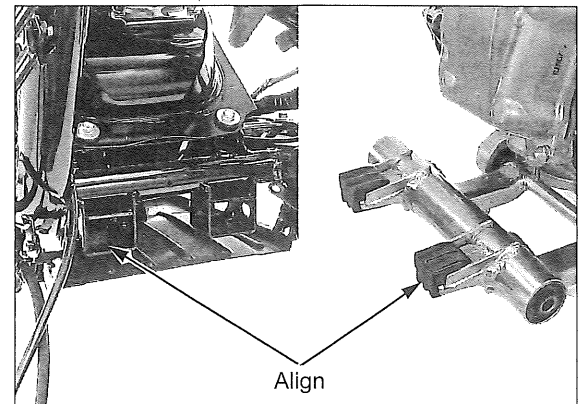

Install the engine hanger link bolt (frame side) [1] and nut [2], then tighten it to the specified torque.

**TORQUE: 59 N·m (6.0 kgf·m, 44 lbf·ft)**

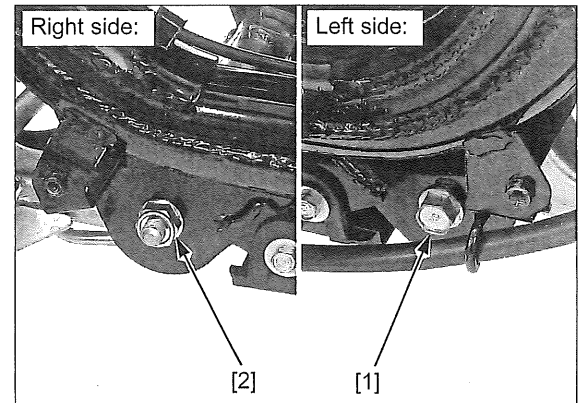

Install the inside washers [1], then set the both rear shock absorber upper mount to the frame.

Install the outside washers [2] and both rear shock absorber upper mounting nuts [3], then tighten them to the specified torque.

**TORQUE: 24 N·m (2.4 kgf·m, 18 lbf·ft)**

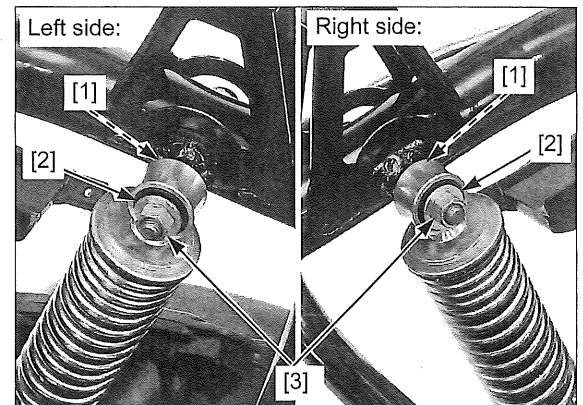

When you replace or remove the engine hanger linkage, tighten the engine hanger link pivot nut (engine side) [1] to the specified torque while holding the pivot bolt [2].

**TORQUE: 49 N·m (5.0 kgf·m, 36 lbf·ft)**

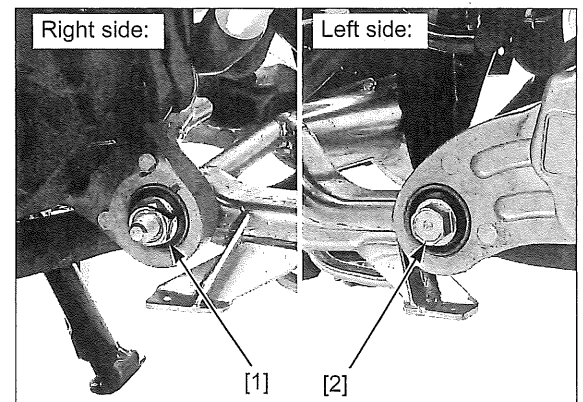

## ENGINE REMOVAL/INSTALLATION

Install the four wire band bosses [1].

Connect the CKP sensor 6P (Black) connector [2].

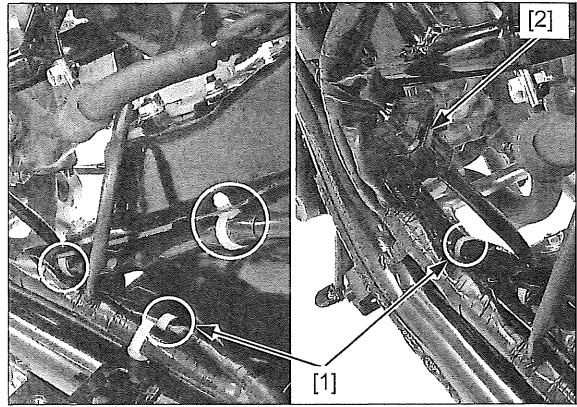

Secure the engine sub harness [1] to the frame clamp [2].

Connect the following:

- ECM 3P (Black) connector [3]
- Engine sub harness 10P connector [4]
- Engine sub harness 6P (Black) connector [5]

Set the ground terminals, then install and tighten the bolt [6].

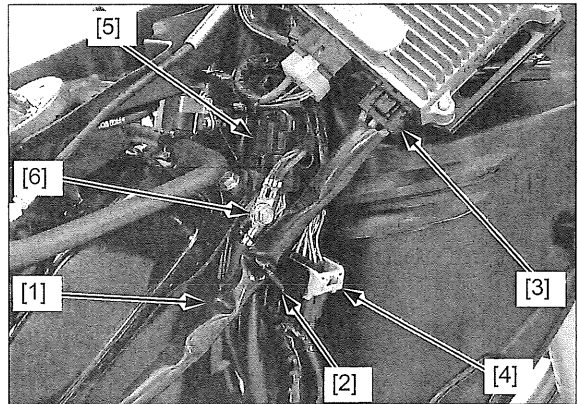

Connect the siphon hose [1] to the radiator and remove the clamp [2].

Install the siphon hose to the hose guide [3].

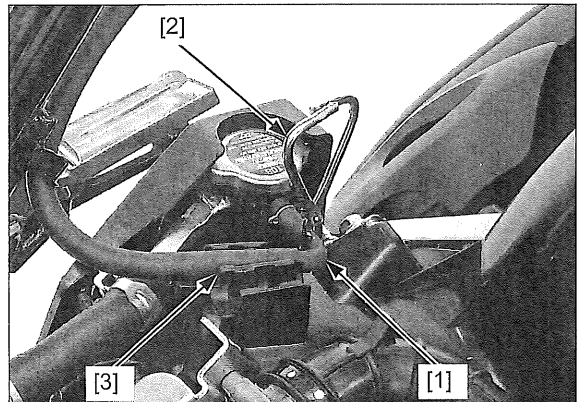

Install the cable clamp [1], then install and tighten the bolt [2].

Connect the throttle cable [3] to the throttle drum [4] and cable bracket [5], then adjust the throttle grip freeplay (page 3-6).

- Set the throttle cable against the connecting hose.

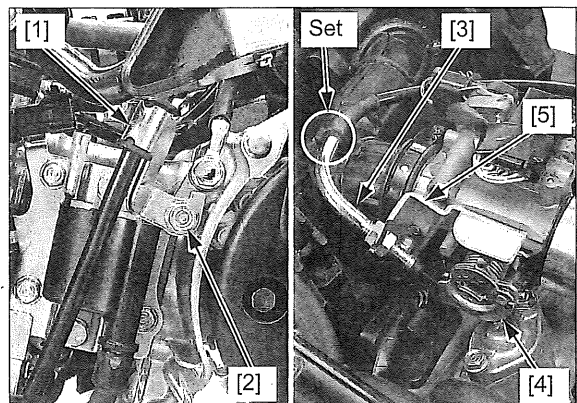

## ENGINE REMOVAL/INSTALLATION

*EXCEPT After '13 model CM type:* Route the EVAP canister-to-intake pipe hose [1] into the clamps [2] and connect it to the intake pipe joint.

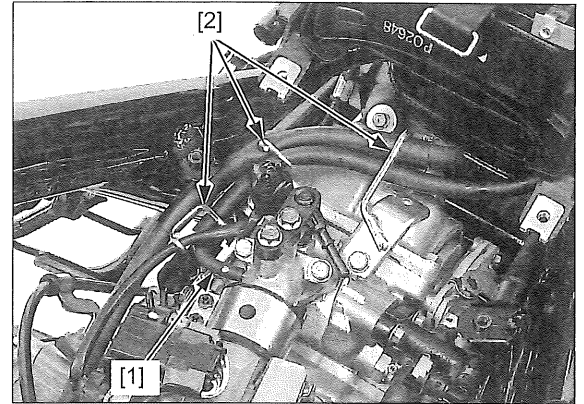

Install the joint pin [1] into the brake arm.  
Route the 2nd rear brake cable [2] into the cable holder [3] and joint pin, then install the adjusting nut [4].

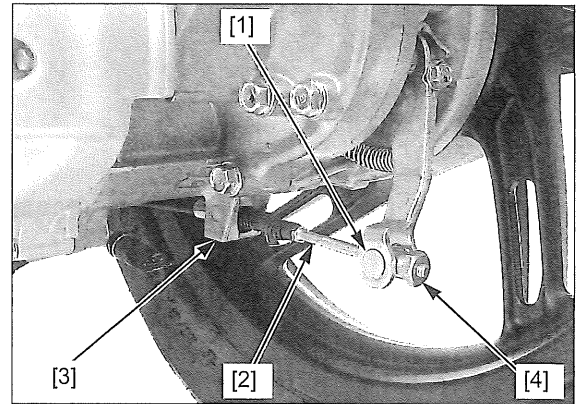

Install the cable clamp [1] and tighten the bolt [2].  
Adjust the rear brake lever freeplay (page 3-18).  
Connect the fuel injector side quick connect fitting and normalize the fuel pressure (page 7-7).

Install the following:

- Floor step (page 2-19)
- Luggage box (page 2-25)

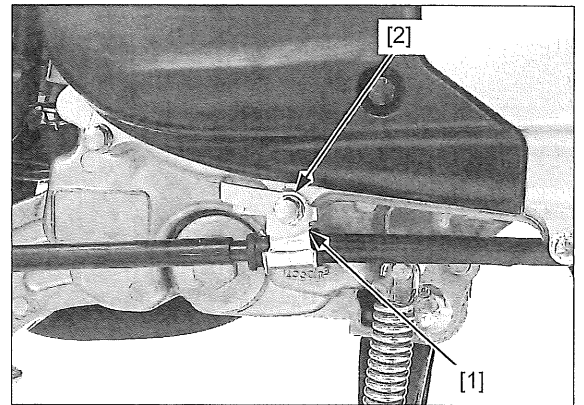

---

**MEMO**

---

# 17. FRONT WHEEL/SUSPENSION/STEERING

---

COMPONENT LOCATION .....	17-2	FORK .....	17-8
SERVICE INFORMATION .....	17-3	HANDLEBAR .....	17-17
TROUBLESHOOTING .....	17-5	HANDLEBAR POST .....	17-23
FRONT WHEEL .....	17-6	STEERING STEM .....	17-24

# FRONT WHEEL/SUSPENSION/STEERING

## COMPONENT LOCATION

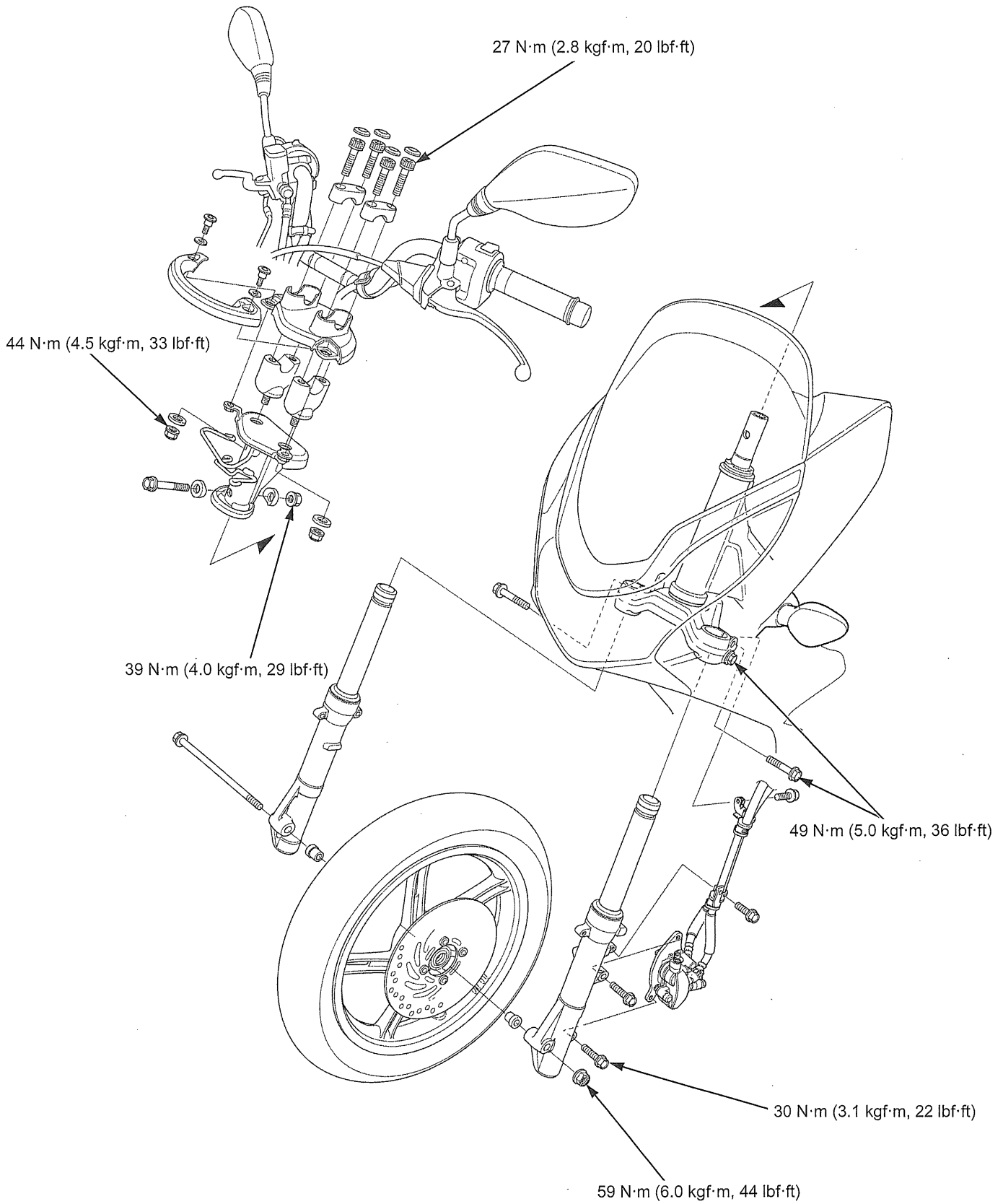



## SERVICE INFORMATION

## GENERAL

**⚠ WARNING**

Frequent inhalation of brake pad dust, regardless of material composition could be hazardous to your health.

- Avoid breathing dust particles.
- Never use an air hose or brush to clean brake assemblies. Use an OSHA-approved vacuum cleaner.

- This section covers the front wheel, fork, handlebar and steering stem.
- When servicing the front wheel, fork or steering stem, support the scooter using a jack or other support.
- A contaminated brake disc or pad reduces stopping power. Discard contaminated pads and clean a contaminated disc with a high quality brake degreasing agent.
- After the front wheel installation, check the brake operation by applying the brake lever.
- For brake system service (page 19-3).

## SPECIFICATIONS

Unit: mm (in)



ITEM		STANDARD	SERVICE LIMIT
Minimum tire tread depth		–	1.5 (0.06)
Cold tire pressure	Up to 90 kg (200 lbs) load	200 kPa (2.00 kgf/cm <sup>2</sup> , 29 psi)	–
	Up to maximum weight capacity	200 kPa (2.00 kgf/cm <sup>2</sup> , 29 psi)	–
Axle runout		–	0.2 (0.01)
Wheel rim runout	Radial	–	2.0 (0.08)
	Axial	–	2.0 (0.08)
Fork	Spring free length	291.8 (11.49)	–
	Pipe runout	–	0.2 (0.01)
	Recommended fluid	Pro Honda Suspension Fluid SS-8 (10W) or equivalent	–
	Fluid level	75 (2.95)	–
	Fluid capacity	122.0 ± 2.5 cm <sup>3</sup> (4.13 ± 0.05 US oz, 4.29 ± 0.05 Imp oz)	–

## TORQUE VALUES

ITEM	Q'TY	THREAD DIA. (mm)	TORQUE N·m (kgf·m, lbf·ft)	REMARKS
Front brake disc socket bolt	4	8	42 (4.3, 31)	ALOC bolt: replace with new ones.
Front axle nut	1	12	59 (6.0, 44)	U-nut
Fork socket bolt	2	8	20 (2.0, 15)	Apply locking agent to the threads.
Bottom bridge pinch bolt	4	10	49 (5.0, 36)	
Brake caliper mounting bolt	2	8	30 (3.1, 22)	ALOC bolt: replace with new ones.
Handlebar upper holder socket bolt	4	8	27 (2.8, 20)	For tightening sequence; See page 17-20
Right/left handlebar switch housing screw	4	5	2.5 (0.26, 1.8)	
Handlebar weight screw	2	6	9 (0.9, 7)	Apply locking agent to the threads.
Front master cylinder holder socket bolt	2	6	12 (1.2, 9)	
Rear brake lever bracket socket bolt	2	6	12 (1.2, 9)	
Rearview mirror lock nut	2	10	34 (3.5, 25)	Left hand threads.
Handlebar lower holder nut	2	10	44 (4.5, 33)	U-nut
Handlebar post nut	1	10	39 (4.0, 29)	U-nut
Rearview mirror adapter bolt	2	10	34 (3.5, 25)	
Steering stem top thread	1	26	–	See page 17-28
Steering stem lock nut	1	26	–	See page 17-28
Throttle cable lock nut (handlebar side)	1	10	1.5 (0.15, 1.1)	
Rear brake lever pivot bolt	1	5	1 (0.1, 0.7)	
Rear brake lever pivot nut	1	5	4.5 (0.46, 3.3)	U-nut

# FRONT WHEEL/SUSPENSION/STEERING

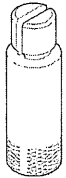
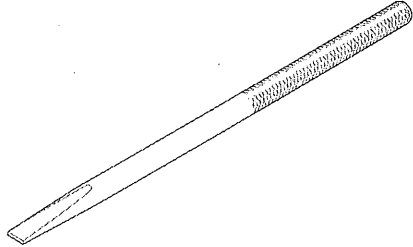
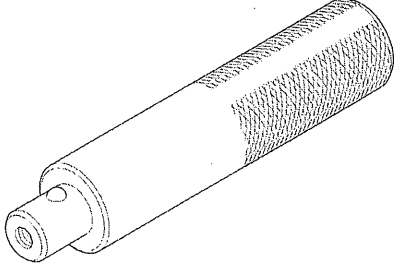
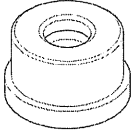
## TOOLS

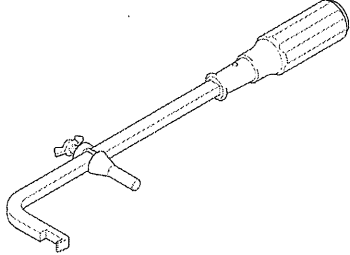
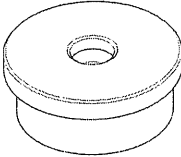
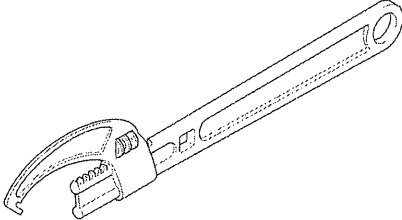
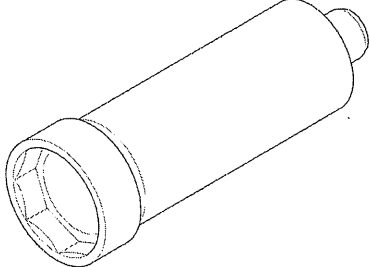
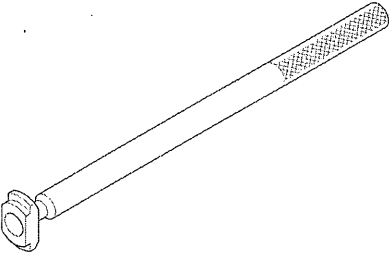
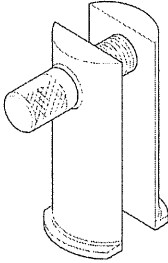
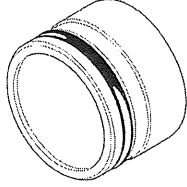
<p>Remover head, 12 mm 07746-0050300</p> 	<p>Bearing remover shaft 07746-0050100</p> 	<p>Driver 07749-0010000</p> 
<p>Attachment, 32 x 35 mm 07746-0010100</p> 	<p>Pilot, 12 mm 07746-0040200</p> 	<p>Oil seal remover 07748-0010001</p>  <p>or equivalent commercially available in U.S.A.</p>
<p>Attachment, 45 x 50 mm 07946-6920100</p> 	<p>Pin spanner 07702-0020001</p> 	<p>Socket wrench 07916-KM10000</p> 
<p>Ball race remover shaft 07GMD-KS40100</p> 	<p>Ball race remover, 34.5 mm 07948-4630100</p>  <p>or 07736-A01000B (U.S.A. only) and a 3/8 x 16 thread slide hammer commercially available in U.S.A.</p>	<p>Attachment, 35.2 mm I.D. 07947-KA20200</p>  <p>(Not available in U.S.A.)</p>

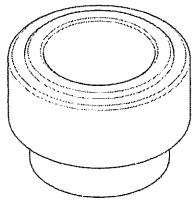
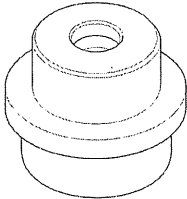
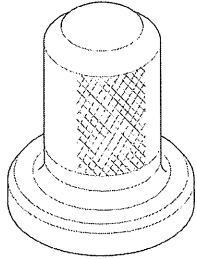
<p>Attachment, 35 mm I.D. 07746-0030400</p> 	<p>Bearing driver attachment 07946-3710701</p> 	<p>Oil seal driver, 53.5 mm 07947-SB00200</p> 
---	--	---

## TROUBLESHOOTING

### Hard steering

- Insufficient tire pressure
- Faulty tire
- Steering stem lock nut too tight
- Faulty steering head bearing
- Faulty steering head bearing race
- Bent steering stem

### Steers to one side or does not track straight

- Bent front axle
- Wheel installed incorrectly
- Worn or damaged front wheel bearings
- Bent fork
- Worn or damaged engine mounting bushings
- Bent frame
- Faulty steering head bearing

### Front wheel wobbles

- Loose front axle fasteners
- Bent rim
- Worn or damaged front wheel bearings

### Front wheel turns hard

- Front brake drag
- Bent front axle
- Faulty front wheel bearings

### Soft suspension

- Low tire pressure
- Deteriorated fork fluid
- Incorrect fork fluid weight
- Insufficient fluid in fork
- Weak fork spring

### Hard suspension

- High tire pressure
- Too much fluid in fork
- Incorrect fork fluid weight
- Bent fork pipes
- Clogged fork fluid passage

### Suspension noisy

- Bent fork slider
- Insufficient fluid in fork
- Loose fork fasteners

## FRONT WHEEL/SUSPENSION/STEERING

### FRONT WHEEL

#### REMOVAL

Loosen the front axle nut [1].

Support the scooter securely using a hoist or equivalent and raise the front wheel off the ground.

Remove the front axle nut.

Remove the front axle out and remove the front wheel.

*Do not operate the brake lever after removing the front wheel.*

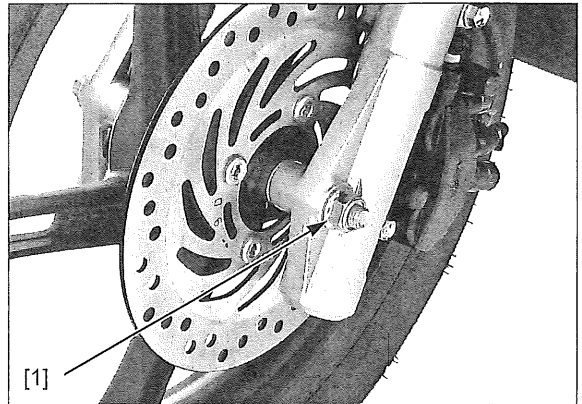

Remove the side collars [1] from both side of the wheel.

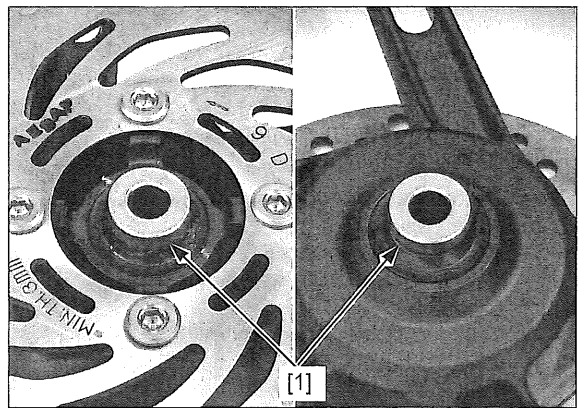

#### INSPECTION

##### AXLE

Place the axle on V-blocks and measure the runout with a dial indicator.

**SERVICE LIMIT: 0.2 mm (0.01 in)**

Actual runout is 1/2 of the total indicator reading.

##### WHEEL BEARING

Turn the inner race of each bearing with your finger, the bearing should turn smoothly and quietly. Also check that the bearing outer race fits tightly in the hub.

*Replace the bearings in pairs.*

Remove and discard the bearings if the races do not turn smoothly, quietly, or if they fit loosely in the hub.

##### WHEEL RIM

Check the wheel rim runout by placing the wheel on a turning stand.

Spin the wheel by hand and read the runout using a dial indicator.

Actual runout is 1/2 the total indicator reading.

**SERVICE LIMIT:**

**Axial: 2.0 mm (0.08 in)**

**Radial: 2.0 mm (0.08 in)**

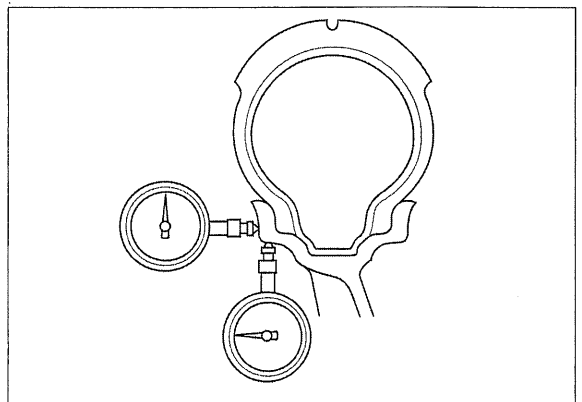

**DISASSEMBLY/ASSEMBLY**

**NOTE:**

Refer to LUBRICATION & SEAL POINTS (page 1-17).

For wheel bearing replacement (page 17-7).

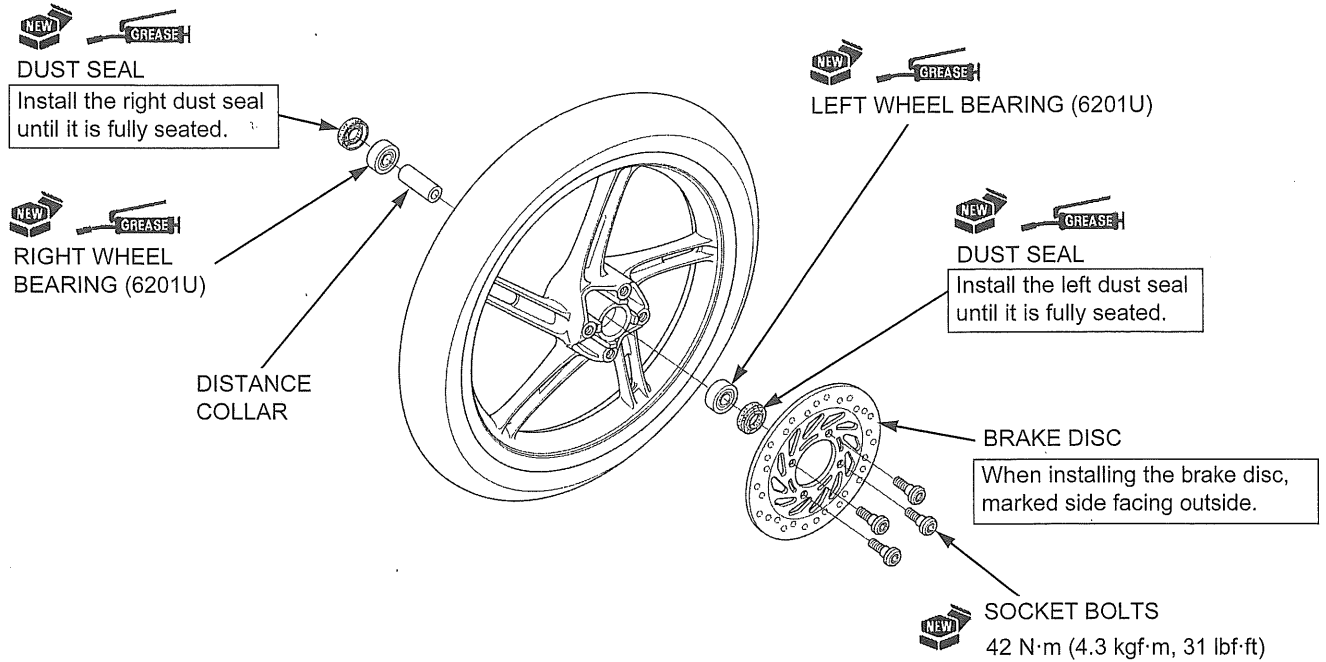

**WHEEL BEARING REPLACEMENT**

Install the bearing remover head [1] into the bearing. From the opposite side, install the bearing remover shaft [2] and drive the bearing out of the wheel hub. Remove the distance collar and drive out the other bearing.

**TOOLS:**

- [1] Remover head, 12 mm                    07746-0050300
- [2] Bearing remover shaft                07746-0050100

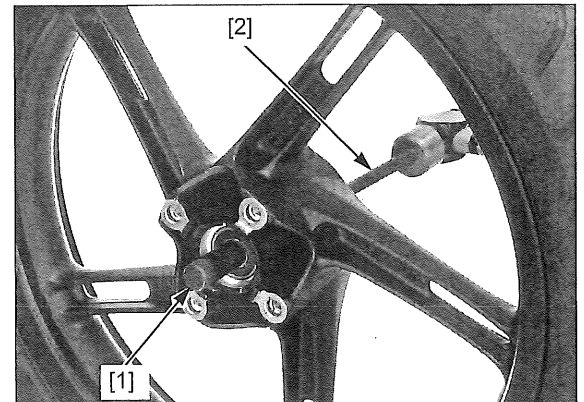

Pack all bearing cavities with grease.

*Never install the old bearings. Once the bearings have been removed, the bearings must be replaced with new ones.*

Drive in a new left bearing [1] squarely with its sealed side facing up until it is fully seated.

**TOOLS:**

- [2] Driver    07749-0010000
- [3] Attachment, 32 x 35 mm                07746-0010100
- [4] Pilot, 12 mm                                07746-0040200

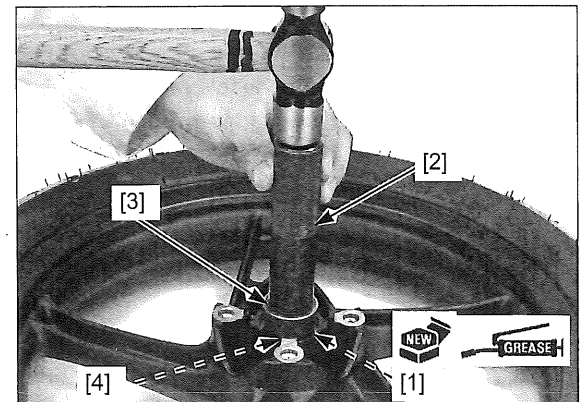

## FRONT WHEEL/SUSPENSION/STEERING

Install the distance collar [1].

Drive in a new right bearing [2] squarely with its sealed side facing up until its inner race is seated on the distance collar.

### TOOLS:

Driver	07749-0010000
Attachment, 32 x 35 mm	07746-0010100
Pilot, 12 mm	07746-0040200

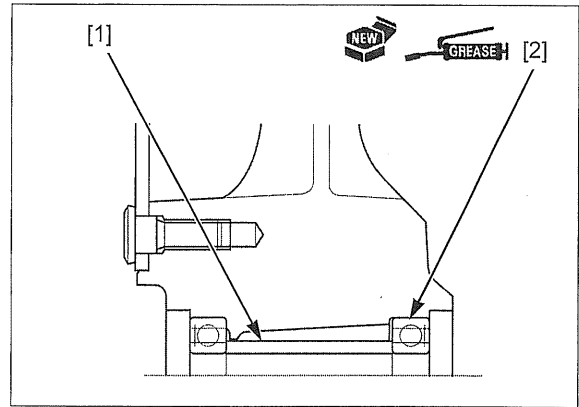

## INSTALLATION

Install the side collars [1] to both side of the wheel.

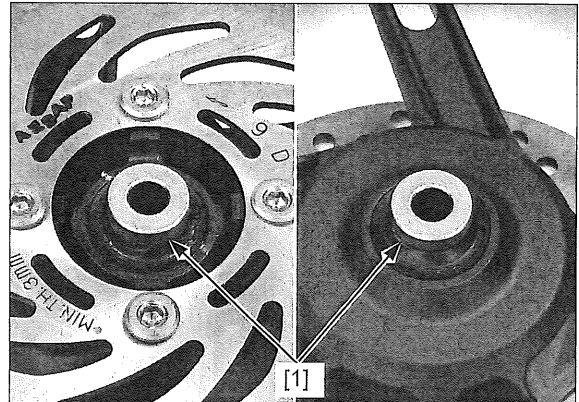

Install the front wheel between the fork legs while inserting the disc between the pads.

Apply thin coat of grease to the front axle [1] sliding surface and install it from the right side.

Install the axle nut [2] and tighten it to the specified torque.

**TORQUE: 59 N·m (6.0 kgf·m, 44 lbf·ft)**

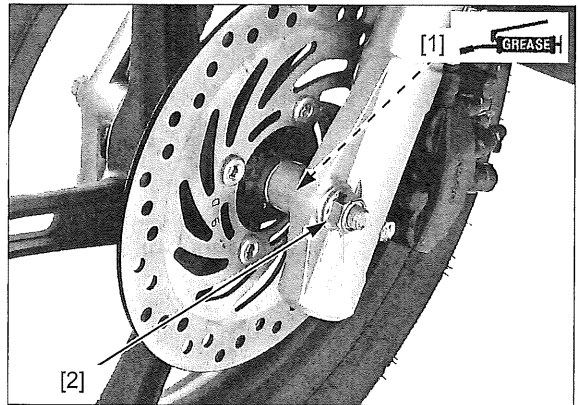

## FORK

### REMOVAL

Remove the following:

- Front fender (page 2-5)
- Front wheel (page 17-6)

*Support the front brake caliper with a piece of wire so that it does not hang from the front brake hose.*

*Do not twist the brake hose.*

Remove the mounting bolts [1] and front brake caliper [2] from the left fork leg.

Remove the clamp bolt [3] and brake hose clamp from the left fork leg.

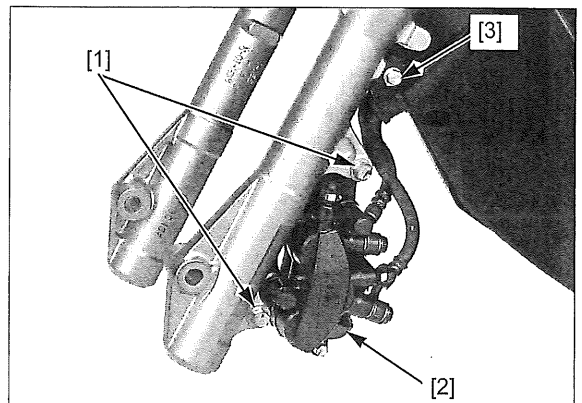

Remove the clamp bolt [1] and brake hose clamp [2] from the steering stem.

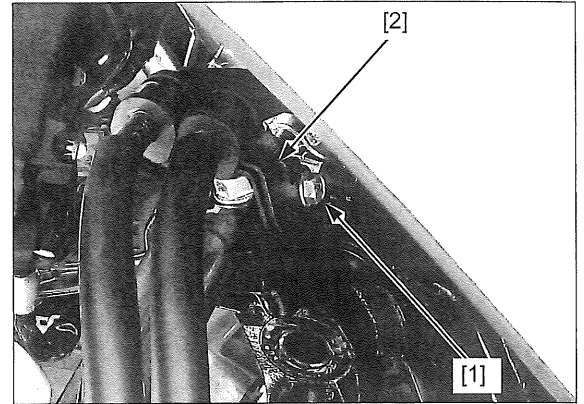

Remove the upper fork pinch bolt [1].  
Loosen the lower fork pinch bolt [2] and remove the fork pipe from the steering stem.

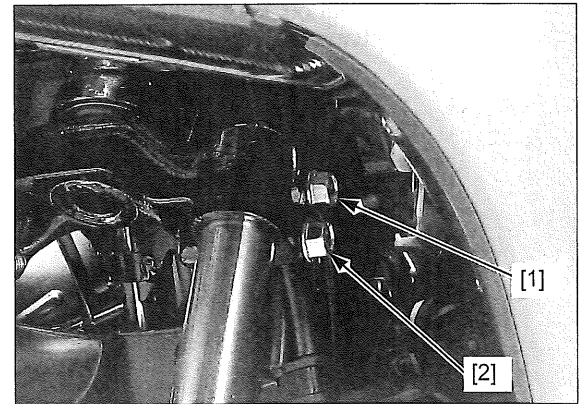

## DISASSEMBLY

Hold the fork slider [1] in a vice with soft jaws or a shop towel.

Loosen the fork socket bolt [2].

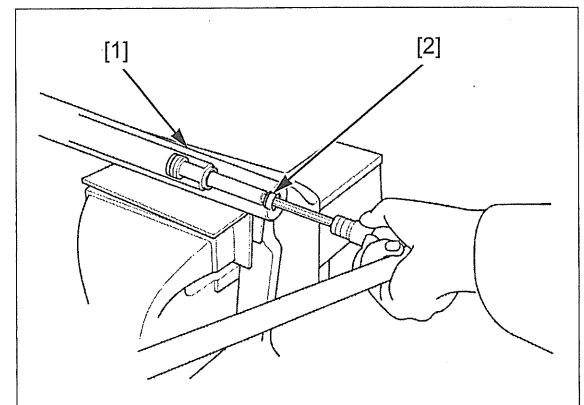

*To prevent loss of tension, do not compress the fork spring more than necessary. The spring seat is under spring pressure. Use care when removing the fork assembly from the hydraulic press.*

Put a suitable tool [1] on the spring seat [2].

Press the spring seat into the fork pipe using a suitable tool and hydraulic press, then remove the stopper ring [3] using a small screwdriver.

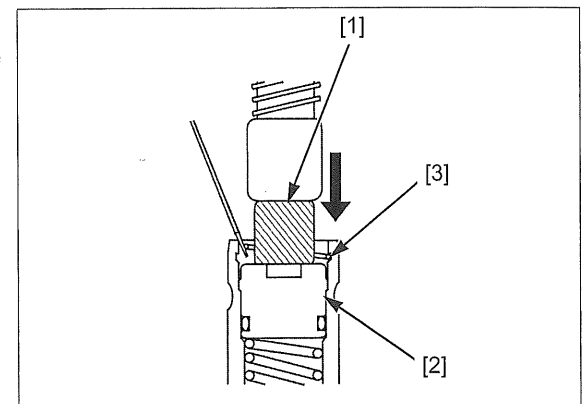

## FRONT WHEEL/SUSPENSION/STEERING

Remove the spring seat [1] and fork spring [2] from the fork pipe [3].

Remove the O-ring [4] from the spring seat.

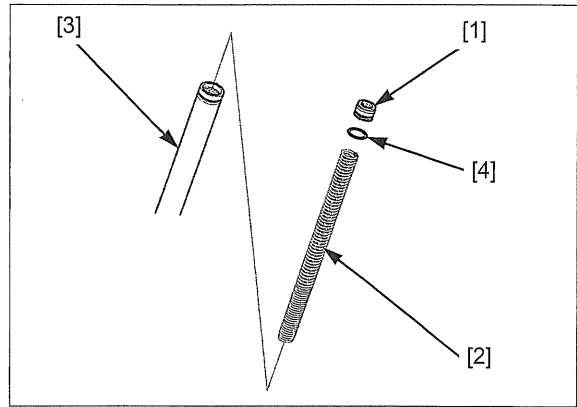

Pour out the fork fluid by pumping the fork pipe several times.

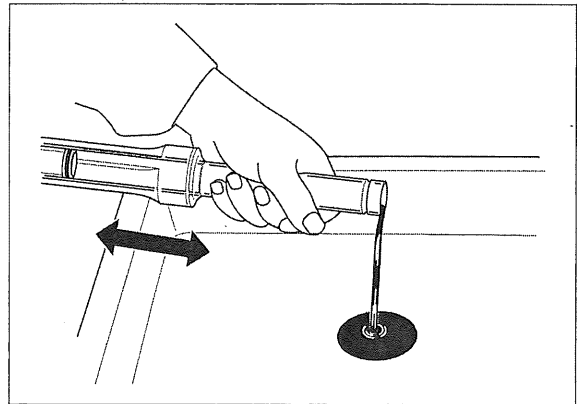

Remove the socket bolt [1] and sealing washer [2].

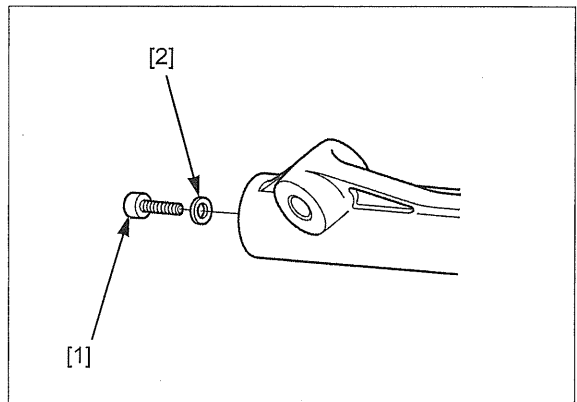

Remove the fork piston [1] and rebound spring [2] from the fork pipe.

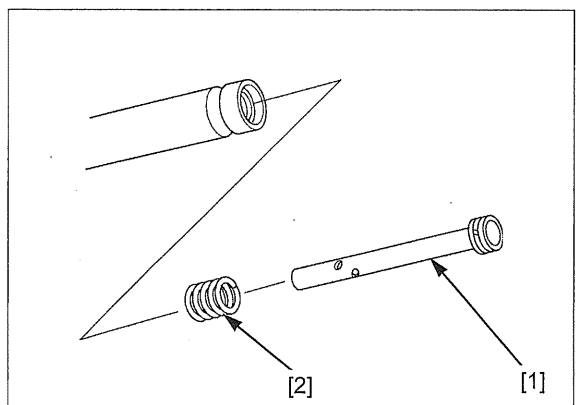



## FRONT WHEEL/SUSPENSION/STEERING

Pull the fork pipe [1] out from the fork slider [2].

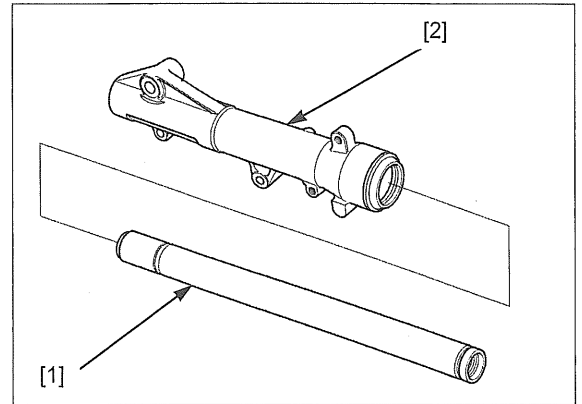

Remove the dust seal [1].

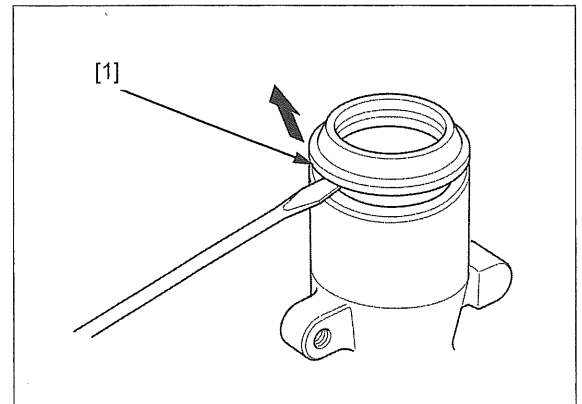

Remove the oil seal stopper ring [1].

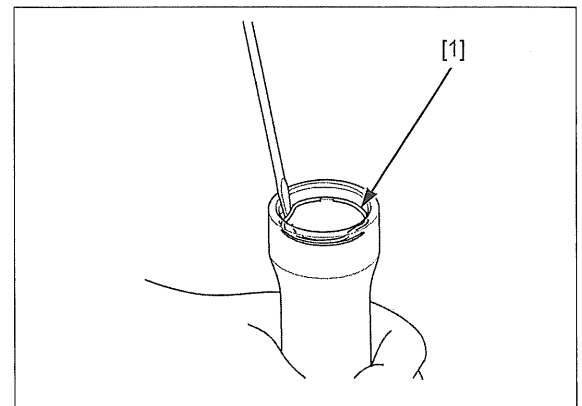

Remove the oil seal [1] using the special tool.

**TOOL:**  
[2] Oil seal remover

07748-0010001 or  
equivalent  
commercially  
available in U.S.A.

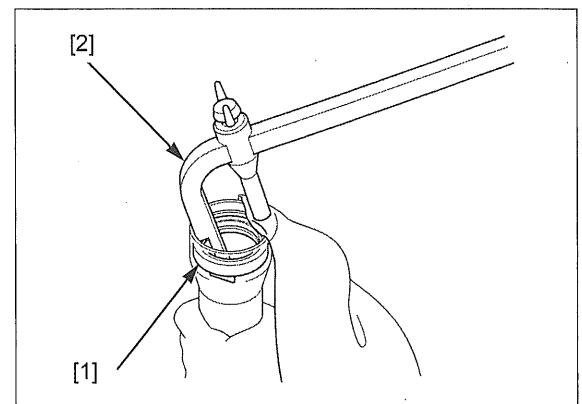

## FRONT WHEEL/SUSPENSION/STEERING

Remove the back-up ring [1] from the fork slider [2].

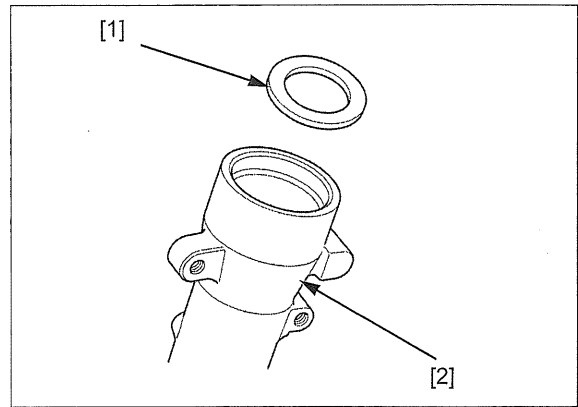

### INSPECTION

#### FORK SPRING

Measure the fork spring [1] free length.

**STANDARD: 291.8 mm (11.49 in)**

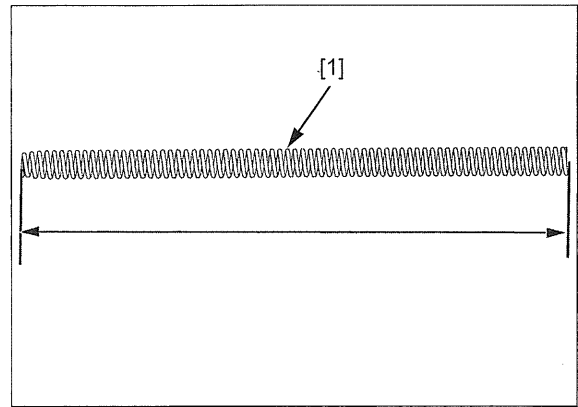

#### FORK PIPE/SLIDER/PISTON

Check the fork pipe [1], fork slider [2], and fork piston [3] for score marks and excessive or abnormal wear.

Check the fork piston ring [4] for wear or damage.  
Check the rebound spring [5] for fatigue or damage.

Replace the components if necessary.

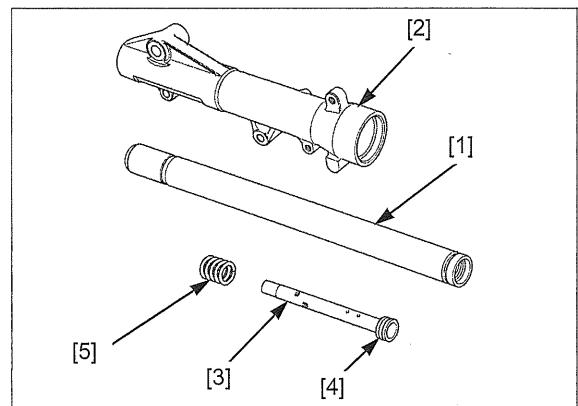

Place the fork pipe on V-block and measure the runout.

Actual runout is 1/2 the total indicator reading.

**SERVICE LIMIT: 0.2 mm (0.01 in)**

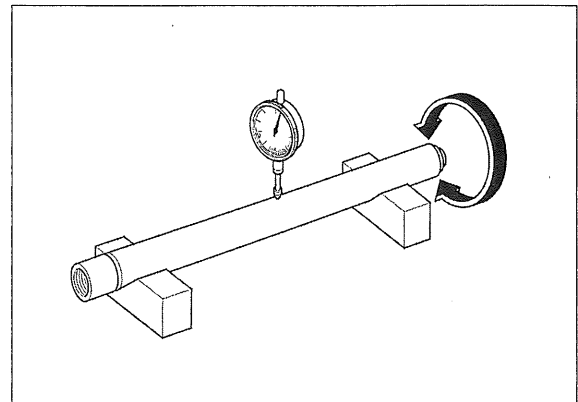

**FORK PIPE BUSHING/BACK-UP RING**

Visually inspect the guide bushing [1] in the fork slider. Replace the fork slider as an assembly if there is excessive scoring or scratching, or if the teflon is worn so that the copper surface appears on more than 3/4 of the entire surface.

Check the back-up ring [2] and replace it if there is any distortion at the points indicated by arrows on the figure.

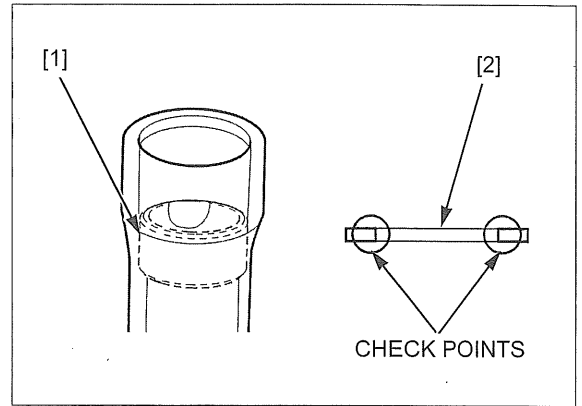

**ASSEMBLY**

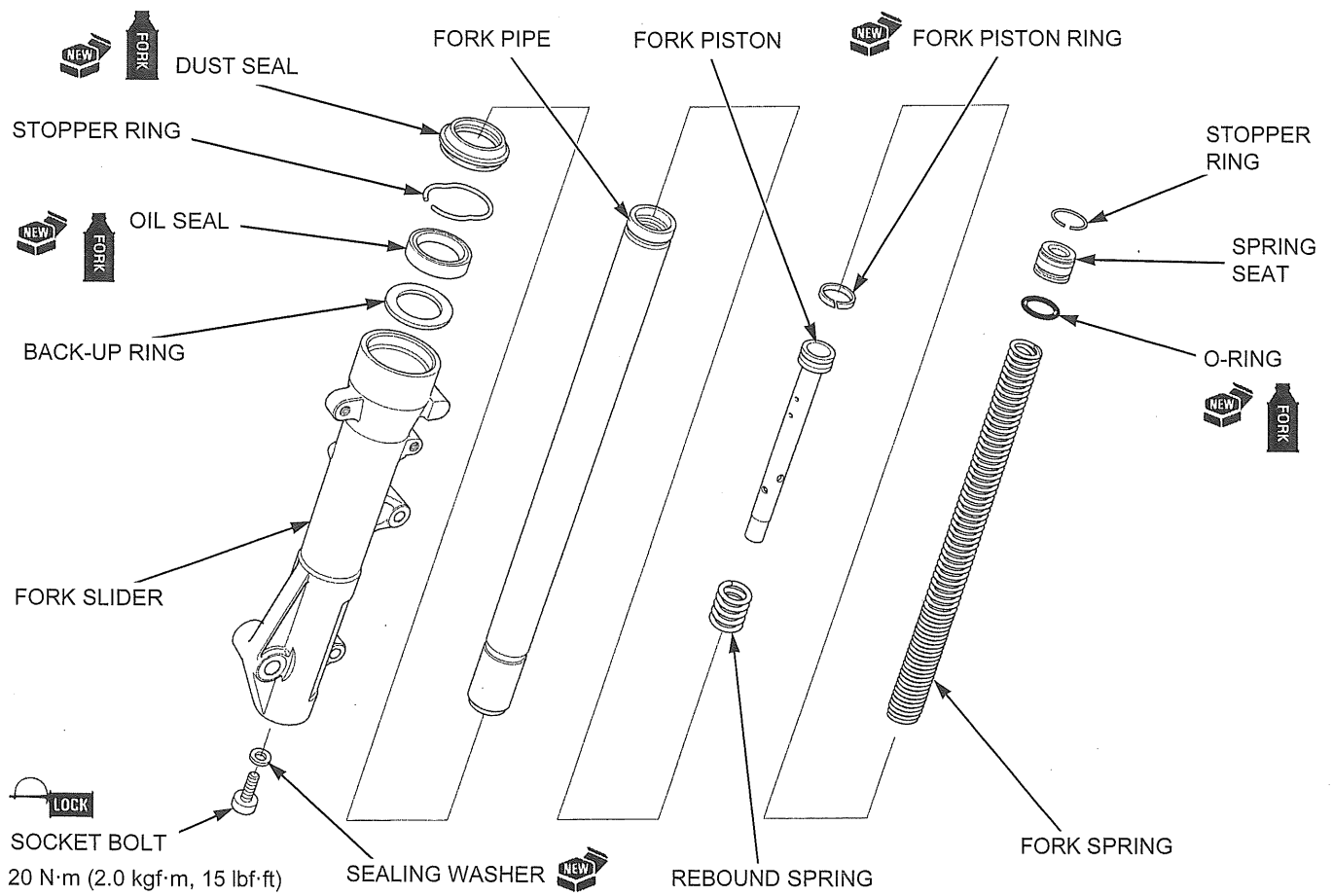

Before assembly, wash all parts with high flash point or non-flammable solvent and wipe them dry.

Install the back-up ring [1] into the fork slider [2].

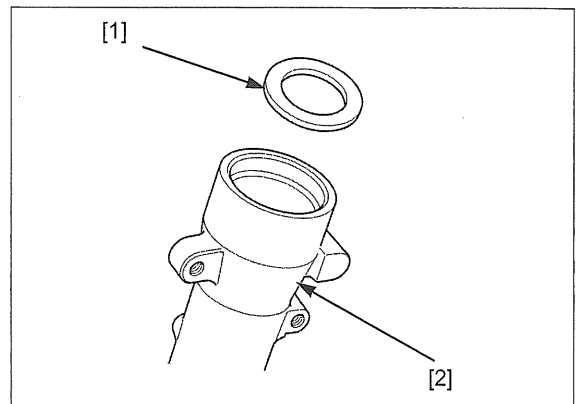

# FRONT WHEEL/SUSPENSION/STEERING

Apply fork fluid to the lip of a new oil seal [1].

*Install the oil seal with its marked side facing up.*

Drive the oil seal into the fork slider using the special tools.

**TOOLS:**

[2] Driver

07749-0010000

[3] Attachment, 45 x 50 mm

07946-6920100

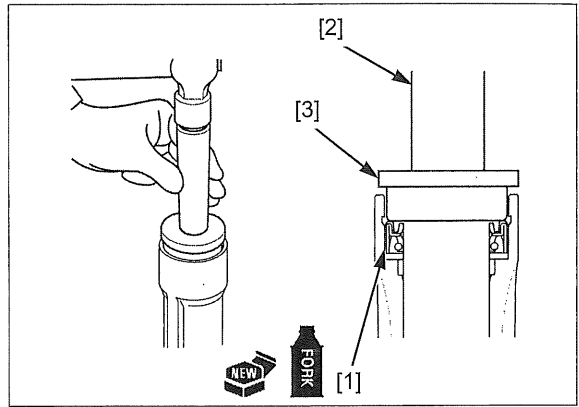

Install the oil seal stopper ring [1] into the stopper ring groove on the fork slider.

Apply fork fluid to a new dust seal [2] lip.

*Do not tap the dust seal lip too hard.*

Install the dust seal until it is fully seated.

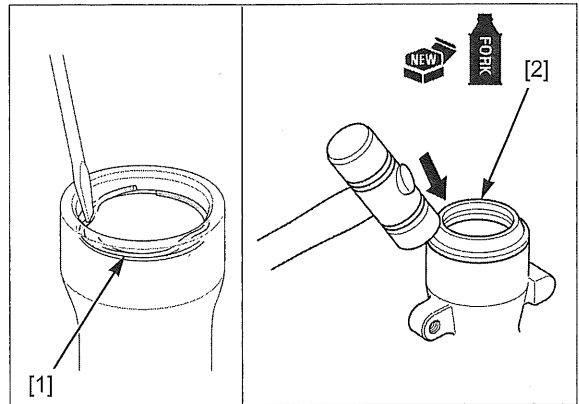

Install the fork pipe [1] into the fork slider [2].

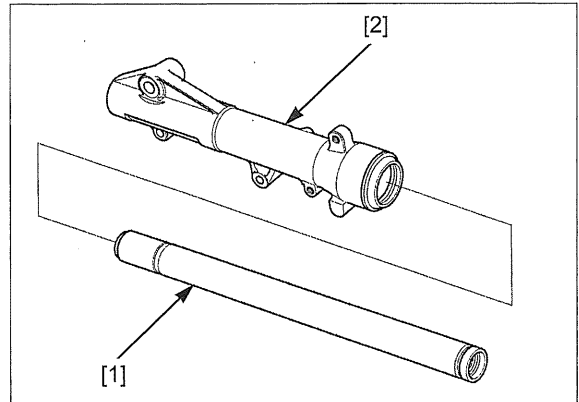

If removing the fork piston ring [1] from the fork piston [2], install a new fork piston ring to the fork piston groove.

*Make sure that the fork piston ring is seated in the groove.*

Install the rebound spring [3] and fork piston into the fork pipe.

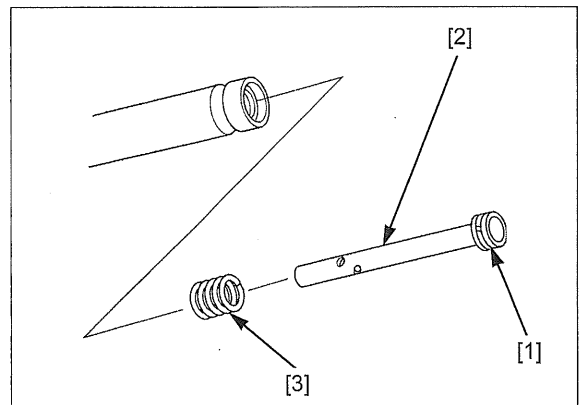

## FRONT WHEEL/SUSPENSION/STEERING

Clean the socket bolt threads and apply locking agent to the socket bolt [1] threads.

Install and temporarily tighten the socket bolt with a new sealing washer [2] to the fork piston.

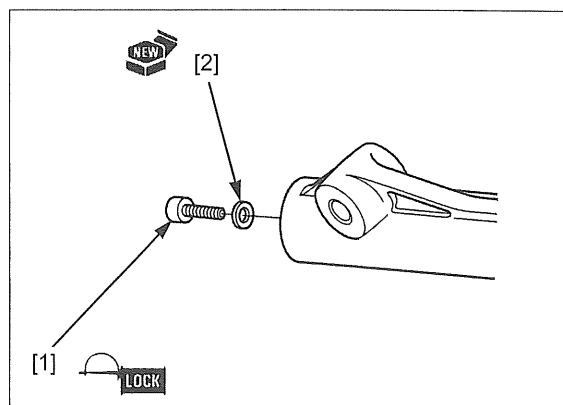

Pour the specified amount of recommended fork fluid into the fork pipe.

### RECOMMENDED FORK FLUID:

**Pro Honda Suspension Fluid SS-8 (10W) or equivalent**

### FORK FLUID CAPACITY:

**$122.0 \pm 2.5 \text{ cm}^3$**

**$(4.13 \pm 0.05 \text{ US oz, } 4.29 \pm 0.05 \text{ Imp oz})$**

Pump the fork pipe several times to remove trapped air from the lower portion of the fork pipe.

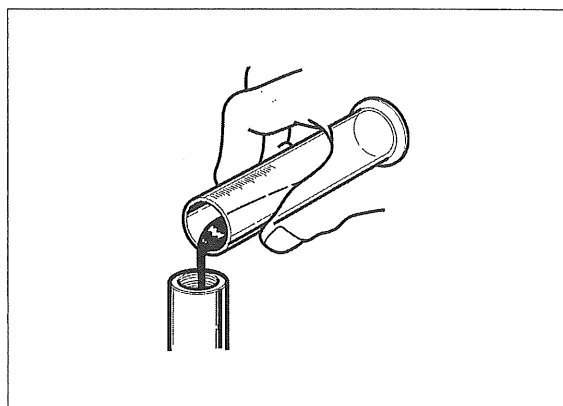

*Be sure the oil level is same in the both forks.*

Compress the fork leg fully and measure the fluid level from the top of the fork pipe.

**FORK FLUID LEVEL: 75 mm (2.95 in)**

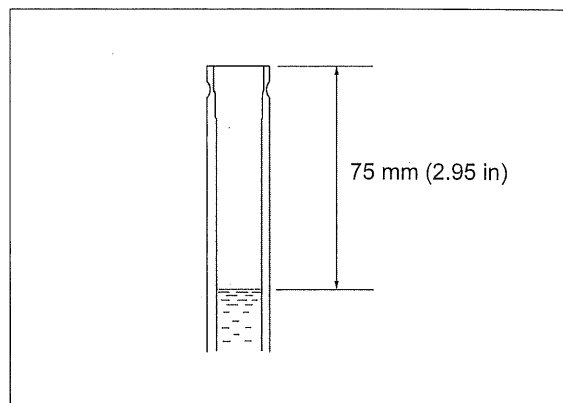

Pull the fork pipe [1] up and install the fork spring [2] with its tapered side facing down.

Coat a new O-ring [3] with fork fluid and install it into the groove in the spring seat [4].

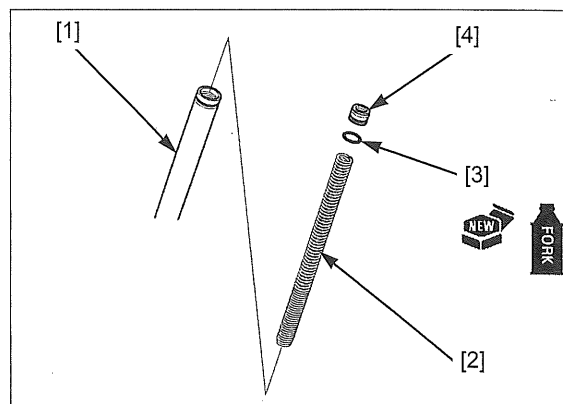

## FRONT WHEEL/SUSPENSION/STEERING

Set the fork assembly, spring seat [1] and stopper ring [2] onto the hydraulic press.  
Put the suitable tool [3] on the spring seat.  
Install the stopper ring into the stopper ring groove of the fork pipe.

*To prevent loss of tension, do not compress the fork spring more than necessary.*

Press the spring seat into the fork pipe until the stopper ring groove is visible.

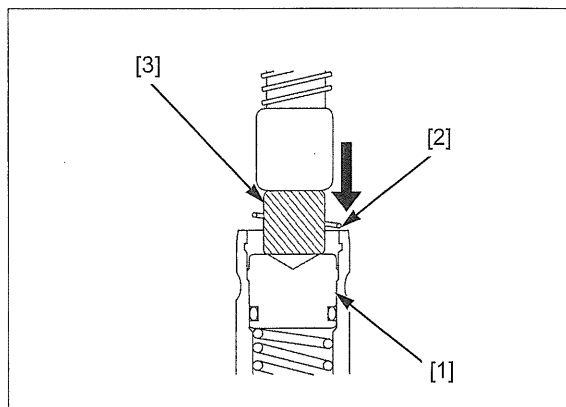

Hold the fork slider [1] in a vise with soft jaws or a shop towel.

Tighten the fork socket bolt [2] to the specified torque.

**TORQUE: 20 N·m (2.0 kgf·m, 15 lbf·ft)**

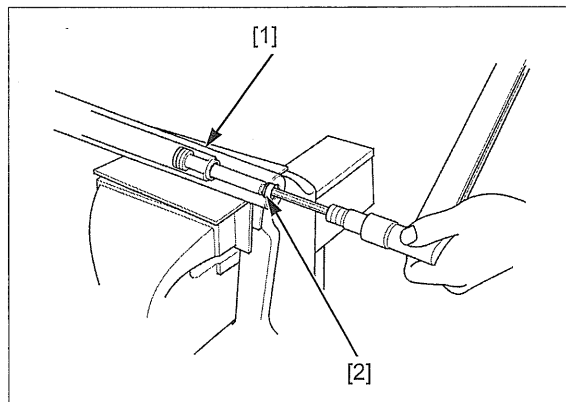

## INSTALLATION

Install the fork into the steering stem and align the groove of the fork pipe with the upper bolt hole of the stem, then install the upper bottom bridge pinch bolt [1].

Tighten the upper and lower bottom bridge pinch bolt [2] to the specified torque.

**TORQUE: 49 N·m (5.0 kgf·m, 36 lbf·ft)**

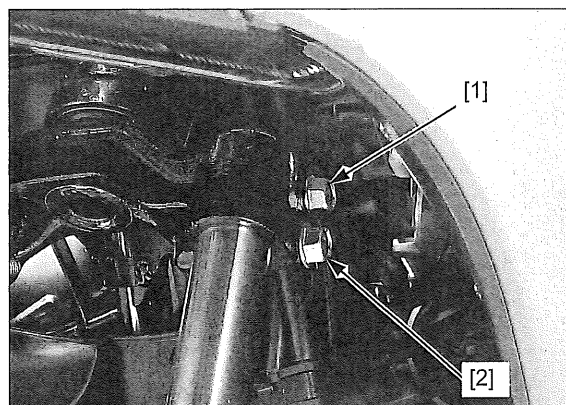

Set the brake hose clamp [1] to the steering stem and install and tighten the clamp bolt [2].

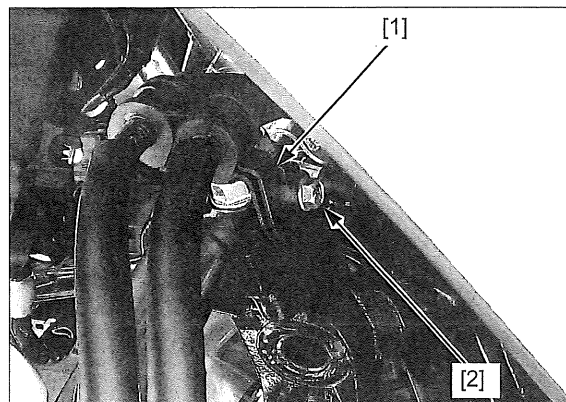

Install the front brake caliper [1] and new mounting bolts [2] to the left fork leg, then tighten them to the specified torque.

**TORQUE: 30 N·m (3.1 kgf·m, 22 lbf·ft)**

Install the brake hose clamp and bolt [3] to the left fork leg.

Install the following:

- Front wheel (page 17-8)
- Front fender (page 2-5)

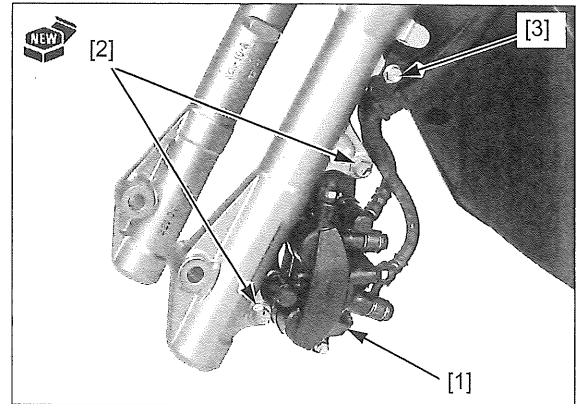

## HANDLEBAR

### REMOVAL

*The rearview mirror lock nuts have left hand threads.* Remove the rearview mirrors [1].  
Remove the wire bands [2].

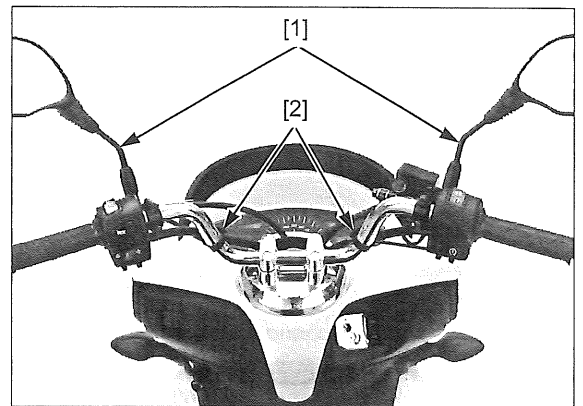

Remove the two socket bolts [1], holder [2] and rear brake lever bracket [3].

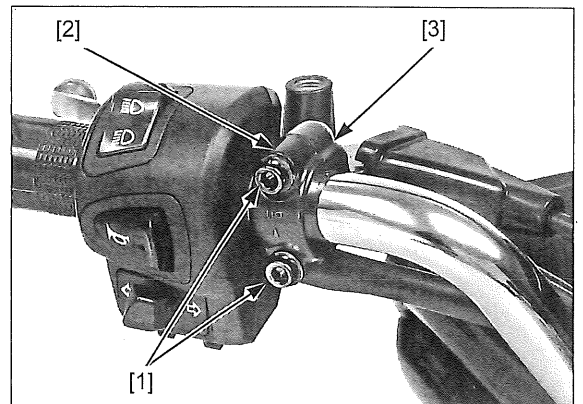

Remove the two screws [1] from the left handlebar switch housing [2].

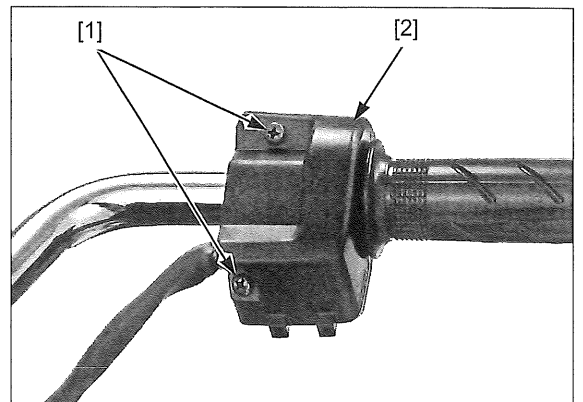

## FRONT WHEEL/SUSPENSION/STEERING

Separate the left handlebar switch [1] and remove it from the handlebar.

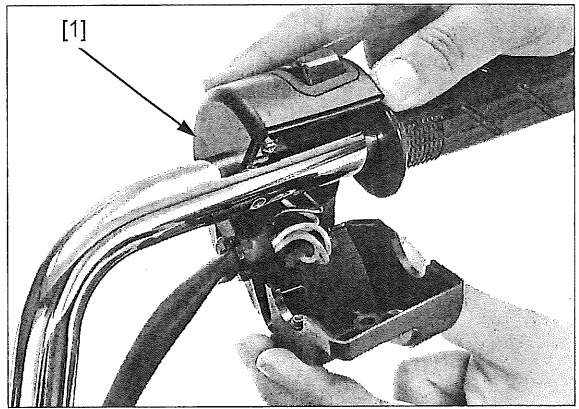

Remove the screw [1], left handlebar weight [2] and left handlebar grip [3].

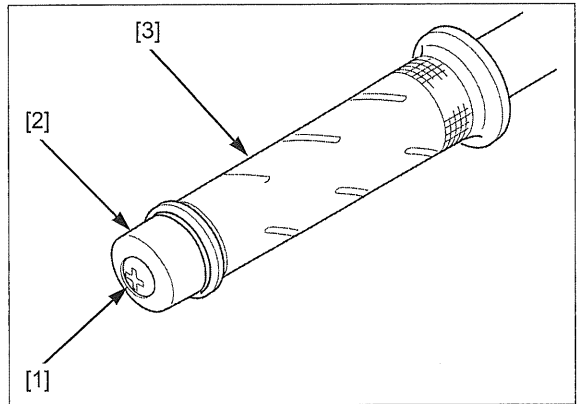

Disconnect the front brake light switch connectors [1].  
Remove the two socket bolts [2], holder [3] and front master cylinder [4].

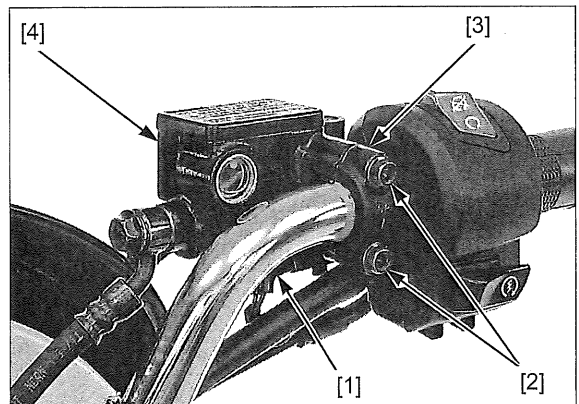

Remove the screw [1] and right handlebar weight [2].

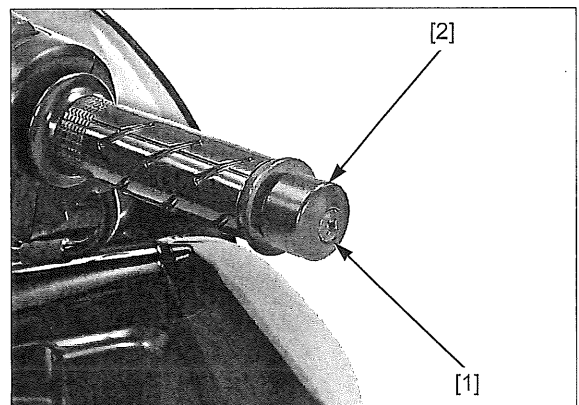



## FRONT WHEEL/SUSPENSION/STEERING

Remove the two screws [1] from the right handlebar switch housing [2].

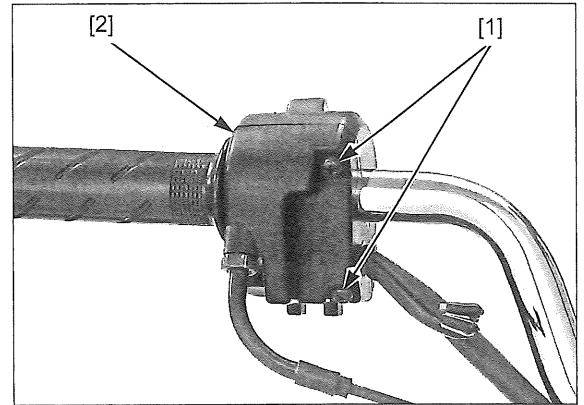

Separate the right handlebar switch [1] and disconnect the throttle cable [2] from the throttle grip [3].

Remove the right handlebar switch and throttle grip.

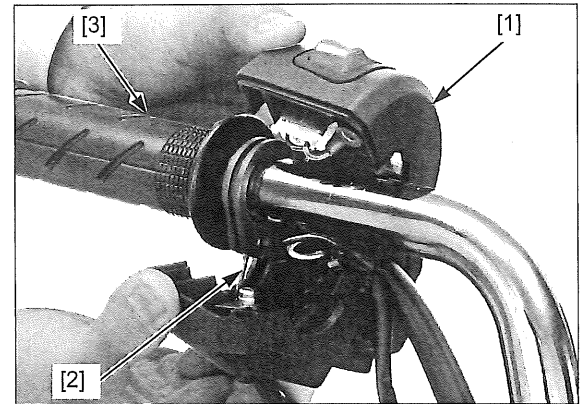

Remove the four caps [1].

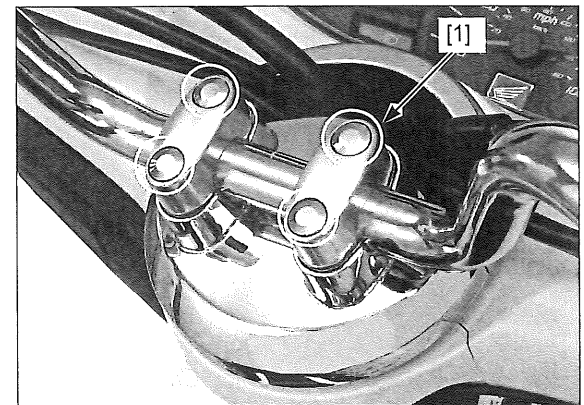

Remove the four socket bolts [1], upper holders [2] and handlebar [3].

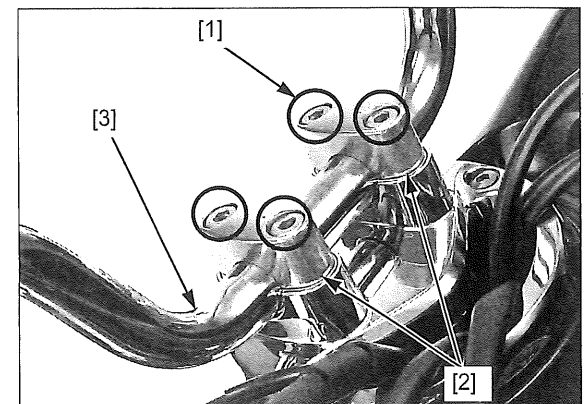

## FRONT WHEEL/SUSPENSION/STEERING

### INSTALLATION

Install the handlebar [1] onto the lower holders by aligning the punch mark [2] on the handlebar with the top edge of the lower holder.

Install the upper holders [3] with the punch marks [4] facing forward.

Install the socket bolts [5] and tighten them to the specified torque in the specified sequence as shown.

**TORQUE: 27 N·m (2.8 kgf·m, 20 lbf·ft)**

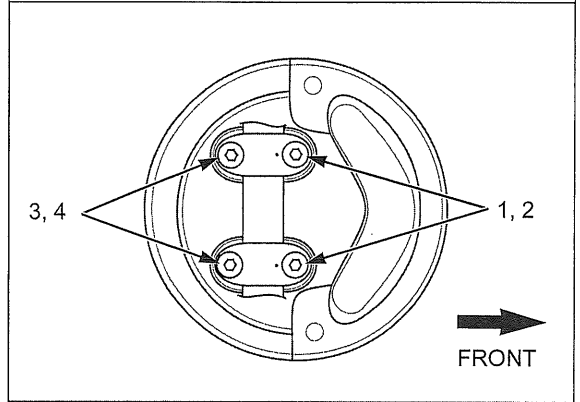
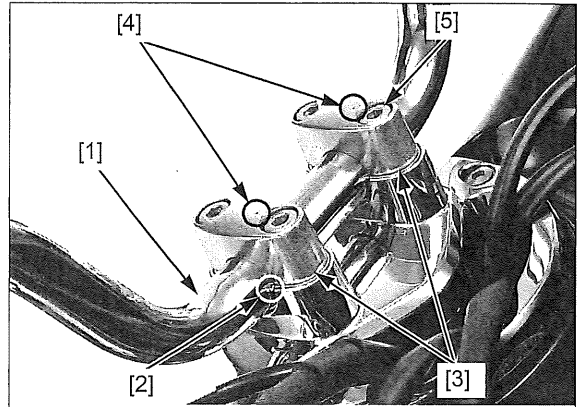

Install the four caps [1].

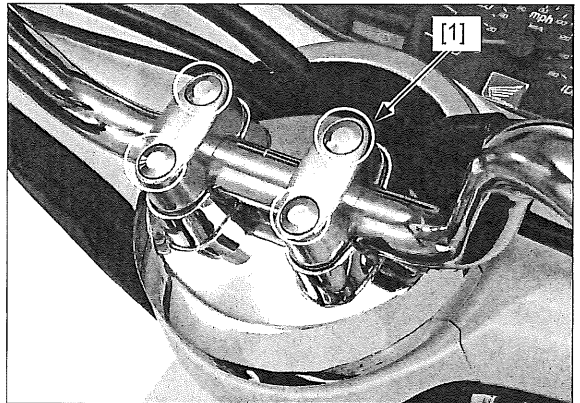

Install the throttle grip [1] onto the handlebar. Apply 0.1 – 0.2 g of grease to the cable end and cable rolling area. Connect the throttle cable [2] to the throttle grip.

Install the right handlebar switch [3] by aligning the locating pin with the hole on the handlebar.

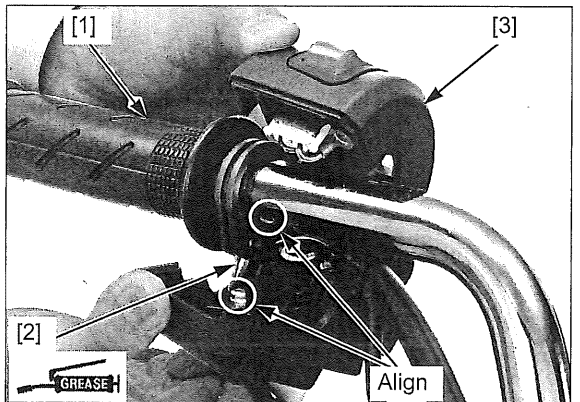

## FRONT WHEEL/SUSPENSION/STEERING

Install the two screws [1] and tighten the front side screw first to the specified torque, then tighten the rear side screw to the specified torque.

**TORQUE: 2.5 N·m (0.26 kgf·m, 1.8 lbf·ft)**

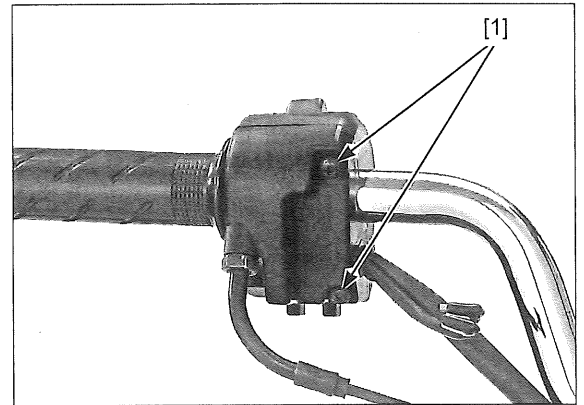

Apply locking agent to the handlebar weight screw [1] threads.

Install the right handlebar weight [2] and handlebar weight screw, then tighten it to the specified torque.

**TORQUE: 9 N·m (0.9 kgf·m, 7 lbf·ft)**

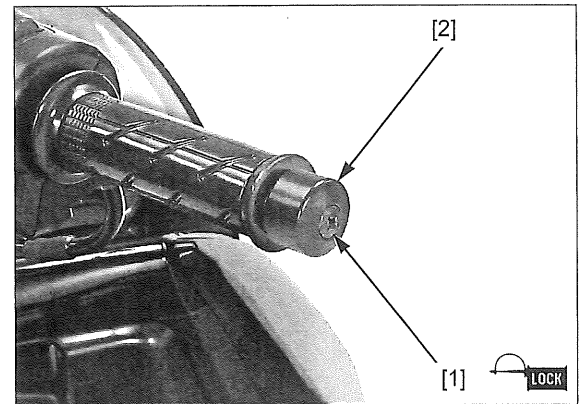

Install the brake master cylinder [1] and holder [2] with the "UP" mark [3] facing up.

Align the edge of the master cylinder with the punch mark [4] on the handlebar and tighten the upper bolt [5] first to the specified torque, then tighten the lower bolt [6] to the specified torque.

**TORQUE: 12 N·m (1.2 kgf·m, 9 lbf·ft)**

Connect the front brake light switch connectors [7].

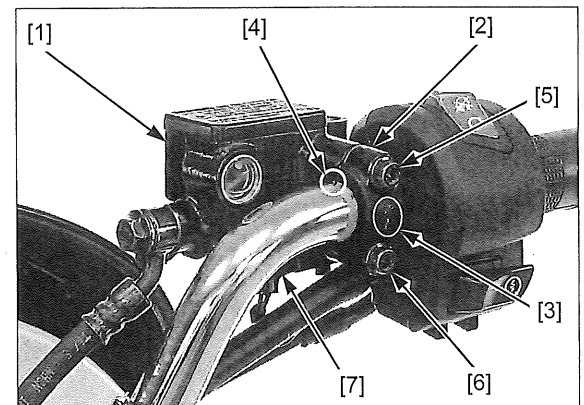

If the handlebar grip [1] was removed, apply Honda Bond A or Honda Handgrip Cement (U.S.A. only) to the inside of the grip and to the clean surfaces of the left handlebar [2].

Wait 3 – 5 minutes and install the grip.

*Allow the adhesive to dry for 1 hour before using.*

Rotate the grip for even application of the adhesive.

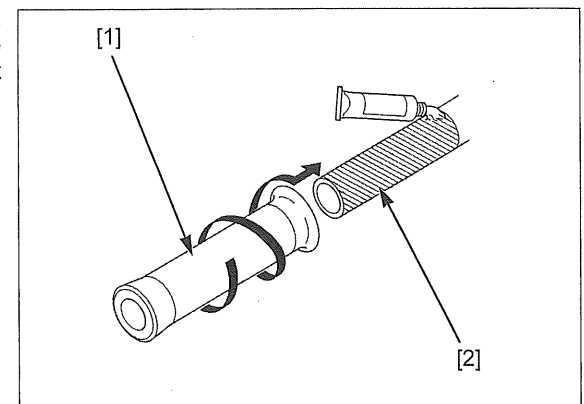

## FRONT WHEEL/SUSPENSION/STEERING

Apply locking agent to the handlebar weight screw [1] threads.

Install the left handlebar weight [2] and handlebar weight screw, then tighten it to the specified torque.

**TORQUE: 9 N·m (0.9 kgf·m, 7 lbf·ft)**

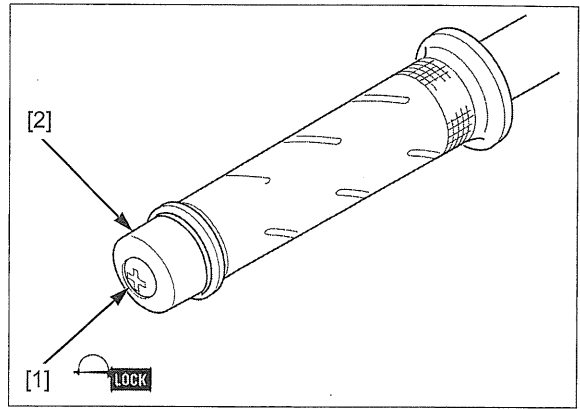

Install the left handlebar switch [1] by aligning the locating pin with the hole on the handlebar.

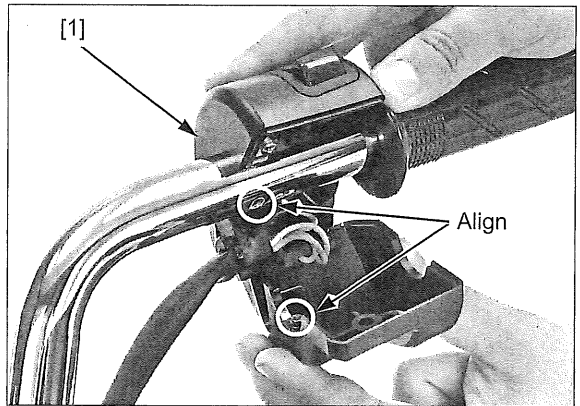

Install the two screws [1] and tighten the front side screw first to the specified torque, then tighten the rear side screw to the specified torque.

**TORQUE: 2.5 N·m (0.26 kgf·m, 1.8 lbf·ft)**

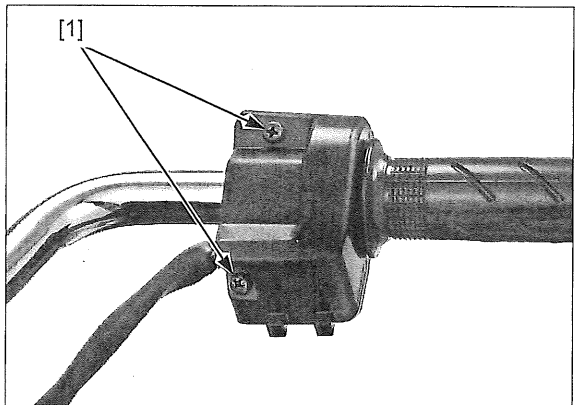

Install the rear brake lever bracket [1] and holder [2] with the "UP" mark [3] facing up.

Align the edge of the rear brake lever bracket with the punch mark [4] on the handlebar and tighten the upper bolt [5] first to the specified torque, then tighten the lower bolt [6] to the specified torque.

**TORQUE: 12 N·m (1.2 kgf·m, 9 lbf·ft)**

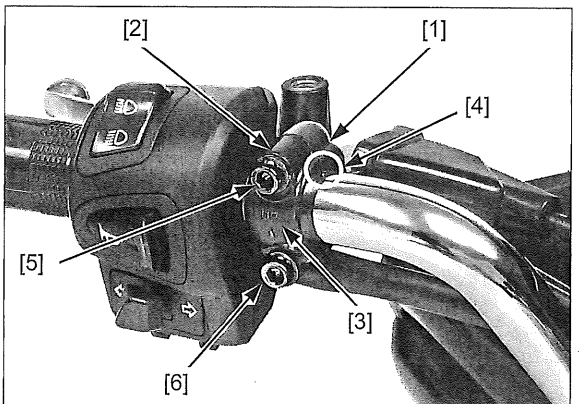

Install the wire bands [1].

*The rearview mirror lock nuts have left hand threads.*

Install the rearview mirrors [2] and tighten the lock nuts to the specified torque.

**TORQUE: 34 N·m (3.5 kgf·m, 25 lbf·ft)**

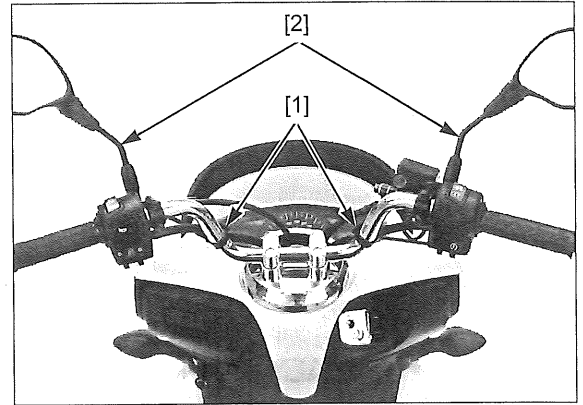

## HANDLEBAR POST

### REMOVAL/INSTALLATION

Remove the following:

- Handlebar (page 17-17)
- Inner cover (page 2-13)
- Socket bolts [1]
- Plastic washers [2]
- Handlebar front cover [3]
- Handlebar rear cover [4]

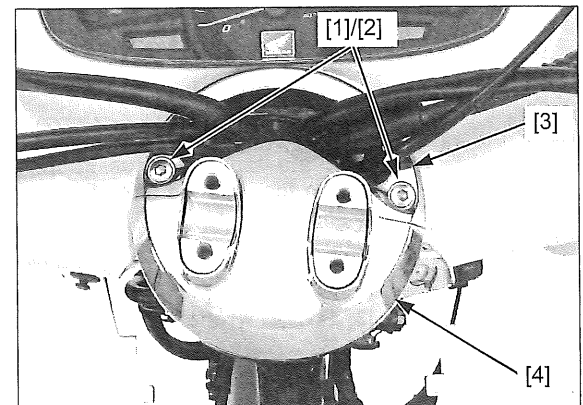

Temporarily install the handlebar [1], then remove the lower holder nuts [2] and washers [3].

Remove the handlebar and lower holders [4].

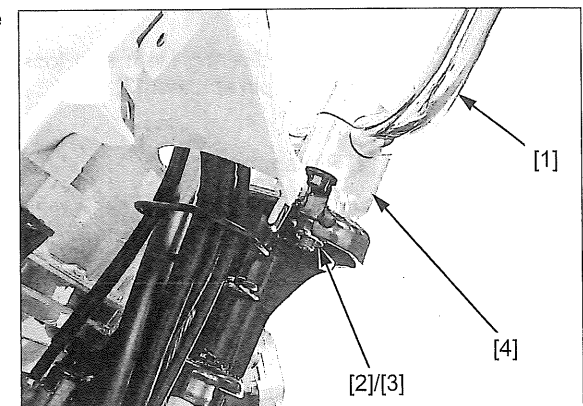

Release the following from the clamps [1]:

- Throttle cable
- 1st rear brake cable
- Right handlebar switch wire
- Left handlebar switch wire
- Rear brake light switch wire
- Front brake hose

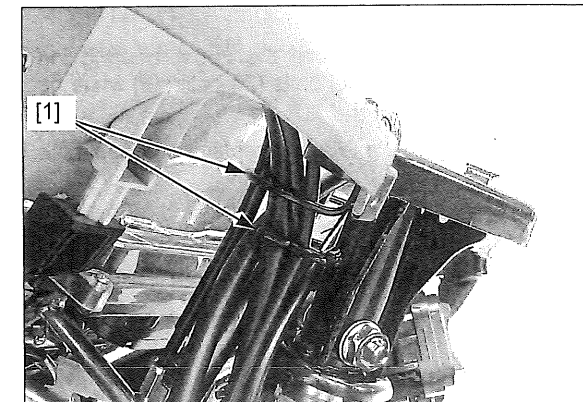

## FRONT WHEEL/SUSPENSION/STEERING

Remove the following:

- Nut [1]
- Rear collar [2]
- Bolt [3]
- Front collar [4]
- Handlebar post [5]

Installation is in the reverse order of removal.

- When tightening the handlebar lower holder nut, temporarily install the handlebar.

### TORQUE:

**Handlebar post nut:**

**39 N·m (4.0 kgf·m, 29 lbf·ft)**

**Handlebar lower holder nut:**

**44 N·m (4.5 kgf·m, 33 lbf·ft)**

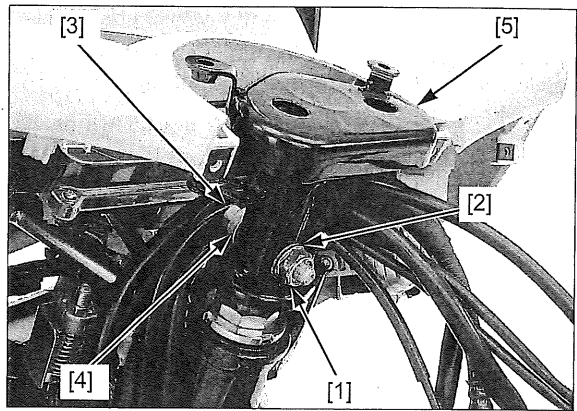

## STEERING STEM

### REMOVAL

Remove the following:

- Fork (page 17-8)
- Handlebar post (page 17-23)

Hold the top thread using the pin spanner [1] and loosen the steering stem lock nut [2] using the socket wrench [3].

### TOOLS:

[1] Pin spanner

07702-0020001

[3] Socket wrench

07916-KM10000

Remove the steering stem lock nut.

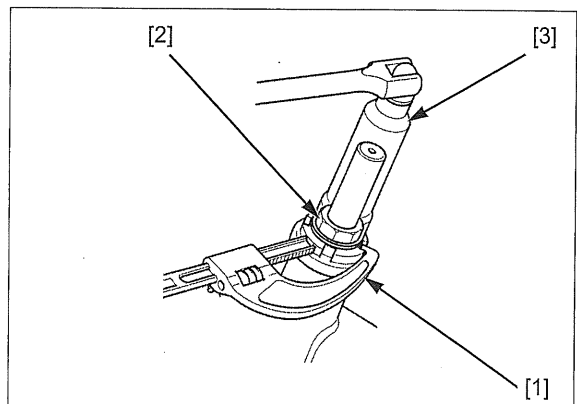

Hold the steering stem and loosen the top thread [1] using the pin spanner [2].

### TOOL:

[2] Pin spanner

07702-0020001

Remove the top thread while holding the steering stem.

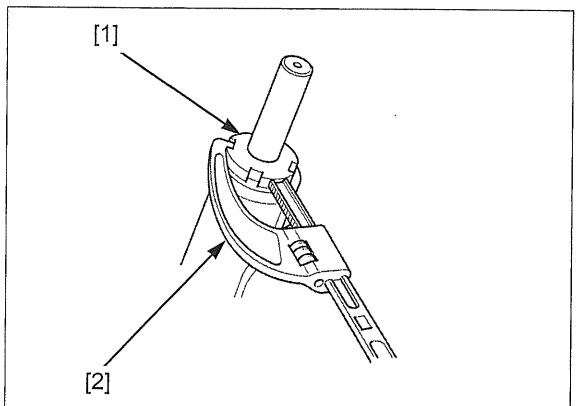

Remove the upper bearing inner race [1] and upper steel balls (23 balls) [2] while holding the steering stem [3].

- Always replace the steel balls and races as a set.

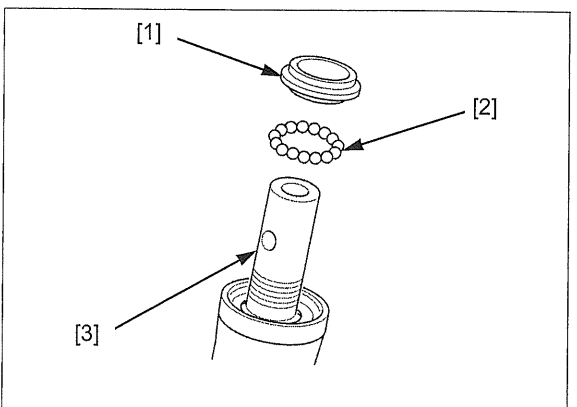

Remove the steering stem [1] and lower steel balls (29 balls) [2].

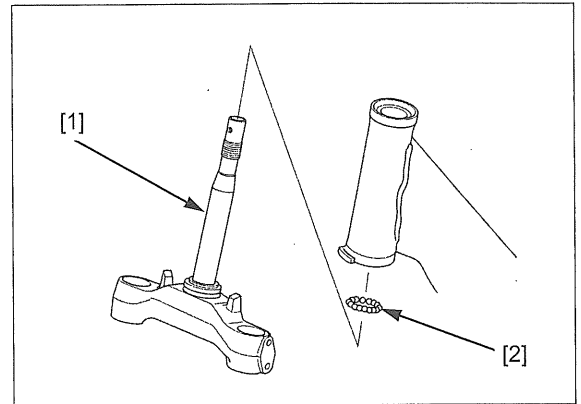

### STEERING STEM BEARINGS REPLACEMENT

- Always replace the steel balls and races as a set.

Remove the upper bearing outer race [1] using the following tool.

**TOOL:**

[2] Ball race remover shaft      07GMD-KS40100

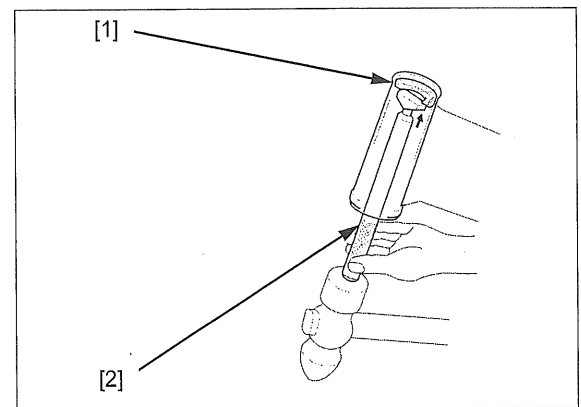

Remove the lower bearing outer race [1] using the following tools.

**TOOLS:**

[2] Ball race remover, 34.5 mm      07948-4630100 or 07736-A01000B (U.S.A. only) and a 3/8 x 16 thread slide hammer commercially available in U.S.A.

[3] Ball race remover shaft      07GMD-KS40100

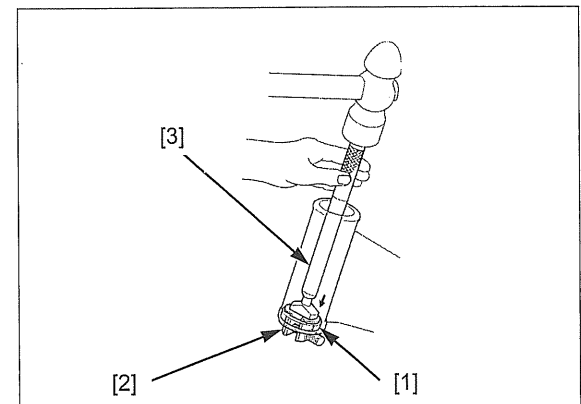

Remove the dust seal [1] from the steering stem lower bearing inner race [2].

Remove the lower bearing inner race with a chisel or equivalent tool being careful not to damage the stem.

Remove the washer [3] from the steering stem.

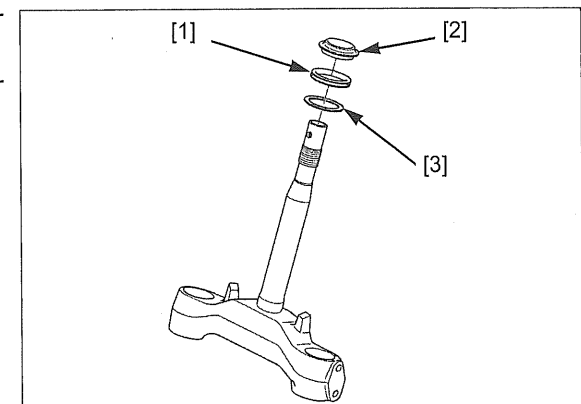

## FRONT WHEEL/SUSPENSION/STEERING

Install the washer [1] to the steering stem.

Install a new lower bearing inner race [2] using the following tool and hydraulic press.

**TOOL:**

[3] Attachment, 35.2 mm I.D.

07947-KA20200  
(Not available in  
U.S.A.) or  
07746-0030400

Attachment, 35 mm I.D.

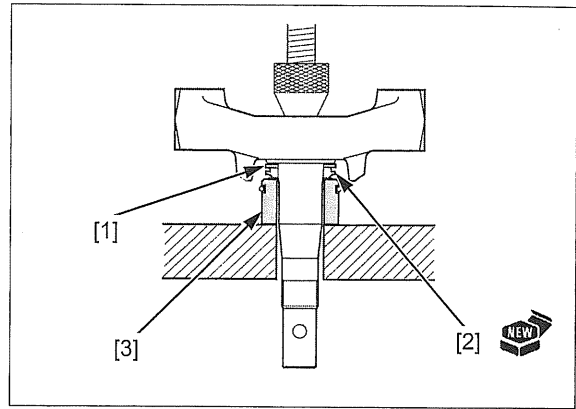

Apply 3 - 5 g of grease with extreme pressure agent (recommended: EXCELIGHT EP2 manufactured by KYODO YUSHI, Japan or Shell ALVANIA EP2 or equivalent) to a new dust seal [1] lip then install it to the lower bearing inner race.

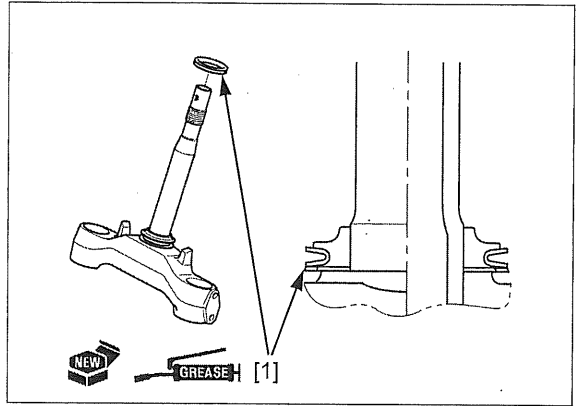

Drive a new upper bearing outer race [1] into the head pipe using the following tools.

**TOOLS:**

[2] Driver

07749-0010000

[3] Bearing driver attachment

07946-3710701

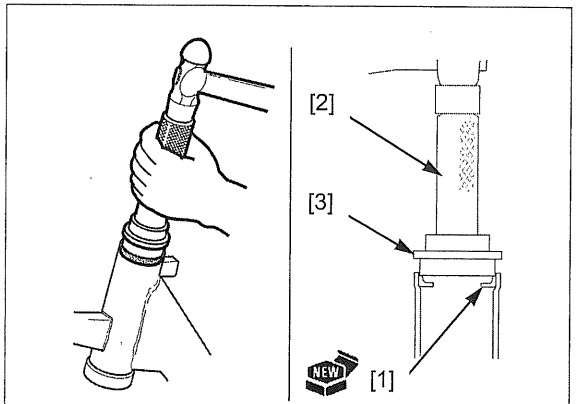

Drive a new lower bearing outer race [1] into the head pipe using the following tools.

**TOOLS:**

[2] Oil seal driver, 53.5 mm

07947-SB00200

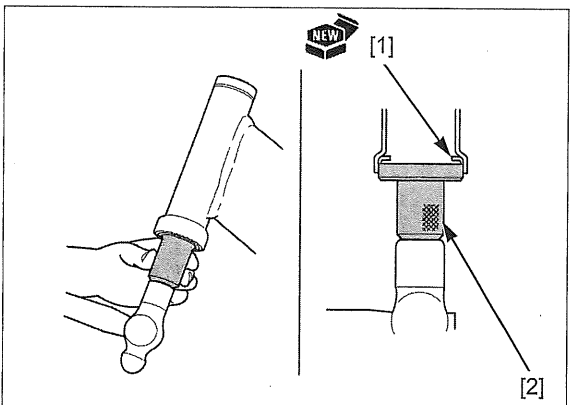



INSTALLATION

- Always replace the steel balls and races as a set.

 : Grease with extreme pressure agent (recommended: EXCELIGHT EP2 manufactured by KYODO YUSHI, Japan or Shell ALVANIA EP2 or equivalent)

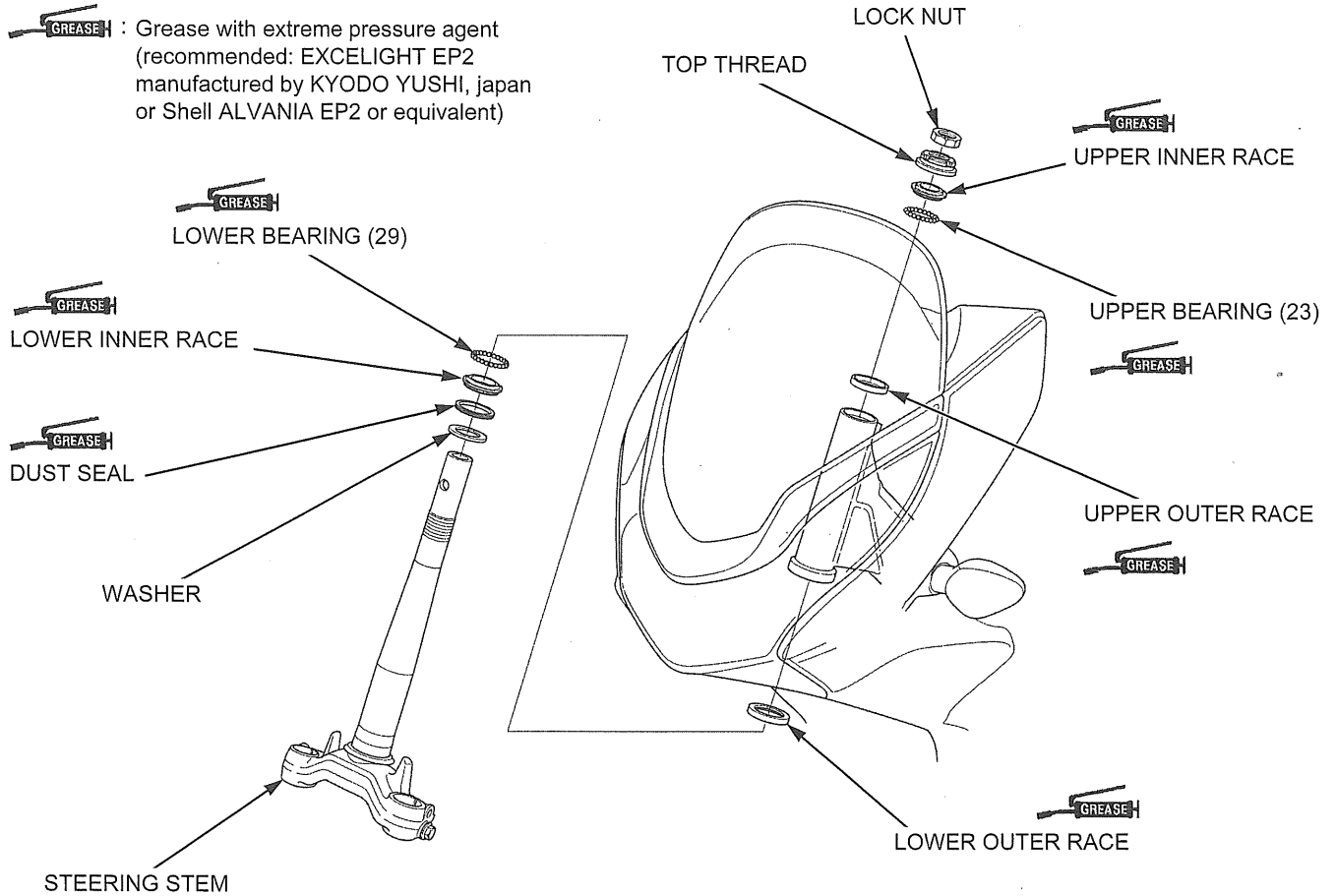

Apply 3 - 5 g of grease with extreme pressure agent (recommended: EXCELIGHT EP2 manufactured by KYODO YUSHI, Japan or Shell ALVANIA EP2 or equivalent) to the lower bearing races.

Attach the steel balls (29 balls) [1] to the lower bearing outer race.

Insert the steering stem [2] into the steering head pipe, being careful not to drop the steel balls.

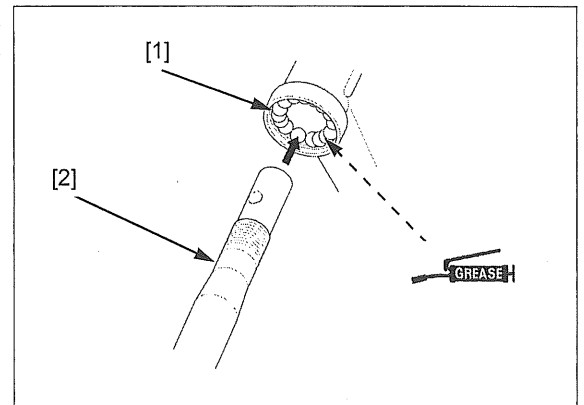

Apply 3 - 5 g of grease with extreme pressure agent (recommended: EXCELIGHT EP2 manufactured by KYODO YUSHI, Japan or Shell ALVANIA EP2 or equivalent) to the upper bearing races.

Install the steel balls (23 balls) [1] onto the upper bearing outer race.

Install a upper bearing inner race [2] onto the stem.

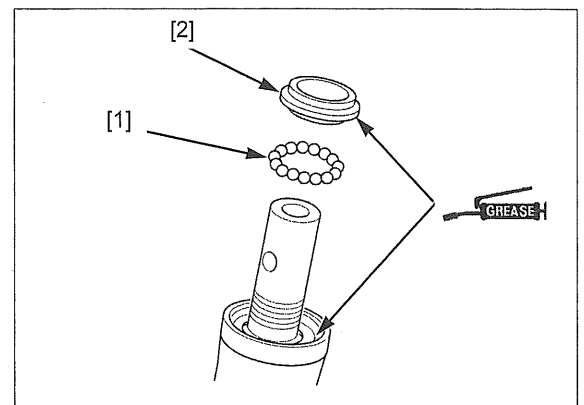

## FRONT WHEEL/SUSPENSION/STEERING

Install the top thread [1].  
Hold the steering stem and tighten the stem top thread to the initial torque using the special tool.

**TOOL:**

[2] Pin spanner 07702-0020001

**TORQUE:**

Actual: 25 N·m (2.5 kgf·m, 18 lbf·ft)

Indicated: 21 N·m (2.1 kgf·m, 15 lbf·ft)

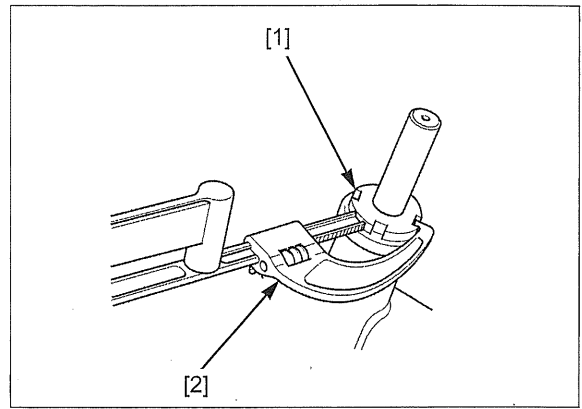

Turn the steering stem [1] lock-to-lock several times to seat the bearing.

Completely loosen the top thread.

Tighten the top thread [2] fully by hand while holding the steering stem, then turn the top thread counterclockwise about 45 degrees.

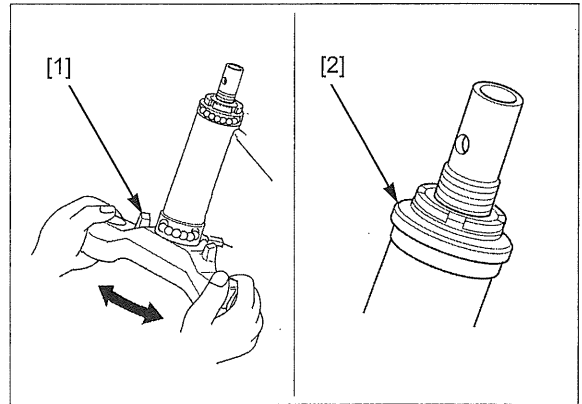

Hold the top thread using the pin spanner and tighten the steering stem lock nut [1] to the specified torque.

**TOOLS:**

[2] Socket wrench 07916-KM10000

[3] Pin spanner 07702-0020001

**TORQUE: 74 N·m (7.5 kgf·m, 55 lbf·ft)**

Make sure the steering stem moves smoothly without play or binding.

Install the following:

- Handlebar post (page 17-23)
- Fork (page 17-16)

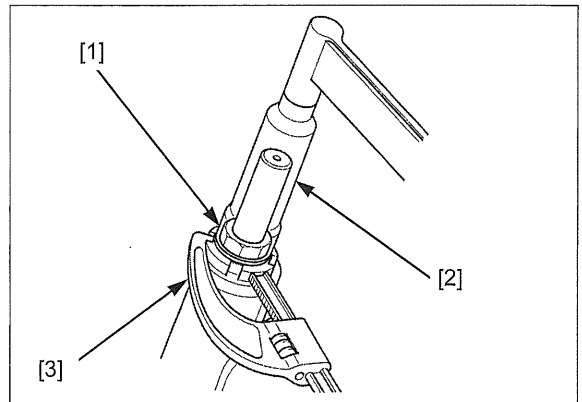

# 18. REAR WHEEL/BRAKE/SUSPENSION

---

COMPONENT LOCATION .....	18-2	REAR WHEEL/SWINGARM .....	18-5
SERVICE INFORMATION .....	18-3	REAR DRUM BRAKE .....	18-8
TROUBLESHOOTING .....	18-4	REAR SHOCK ABSORBER .....	18-12

**REAR WHEEL/BRAKE/SUSPENSION**

**COMPONENT LOCATION**

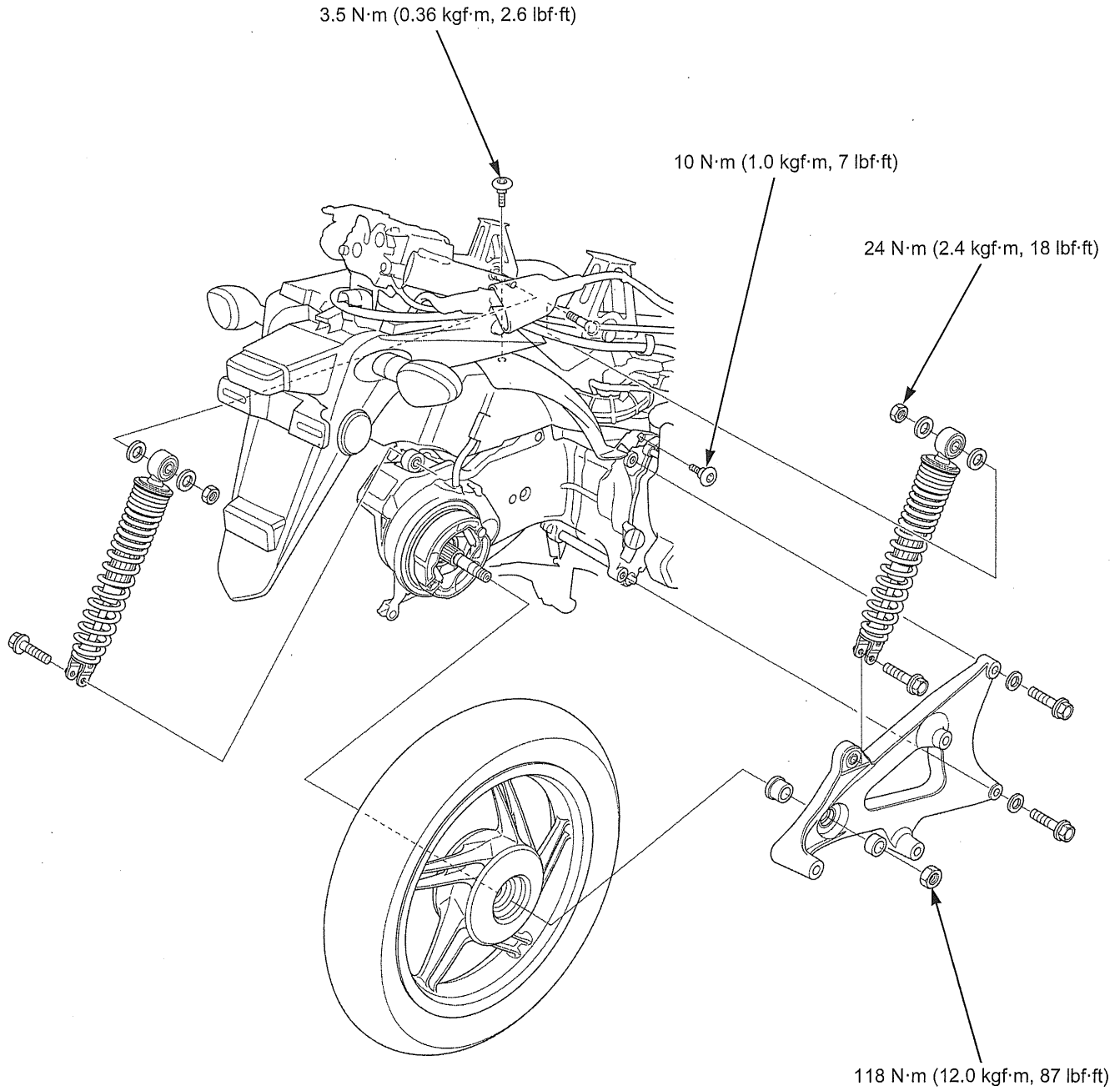

# SERVICE INFORMATION

## GENERAL

### ⚠ WARNING

Frequent inhalation of brake shoe dust, regardless of material composition could be hazardous to your health.

- Avoid breathing dust particles.
- Never use an air hose or brush to clean brake assemblies. Use an OSHA-approved vacuum cleaner.

- Use genuine Honda replacement bolts and nuts for all suspension pivots and mounting points.

## SPECIFICATIONS



Unit: mm (in)

ITEM		STANDARD	SERVICE LIMIT
Minimum tire tread depth		—	2.0 (0.08)
Cold tire pressure	Up to 90 kg (200 lbs) load	225 kPa (2.25 kgf/cm <sup>2</sup> , 33 psi)	—
	Up to maximum weight capacity	250 kPa (2.50 kgf/cm <sup>2</sup> , 36 psi)	—
Wheel rim runout	Radial	—	2.0 (0.08)
	Axial	—	2.0 (0.08)
Brake	Brake lever freeplay	10 – 20 (0.4 – 0.8)	—
	Brake drum I.D.	130.0 – 130.2 (5.12 – 5.13)	131.0 (5.16)

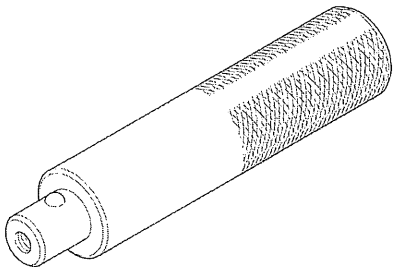
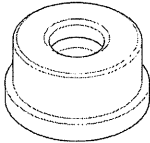

## TORQUE VALUES

ITEM	Q'TY	THREAD DIA. (mm)	TORQUE N·m (kgf·m, lbf·ft)	REMARKS
Rear axle nut	1	16	118 (12.0, 87)	U-nut, Apply oil to the threads and seating surface.
Shock absorber upper mounting nut	2	10	24 (2.4, 18)	
Rear brake arm bolt	1	6	10 (1.0, 7)	ALOC bolt: replace a with new one.
Rear inner fender socket bolt				
- Engine side	1	6	10 (1.0, 7)	
- Air cleaner side	1	6	3.5 (0.36, 2.6)	

## TOOLS

<p>Driver 07749-0010000</p> 	<p>Attachment, 37 x 40 mm 07746-0010200</p> 	<p>Pilot, 17 mm 07746-0040400</p> 
---	---	---

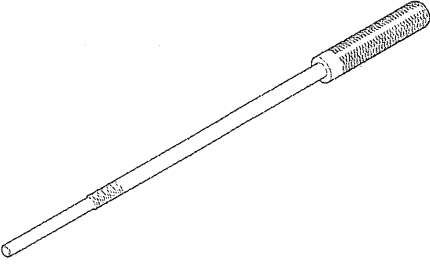
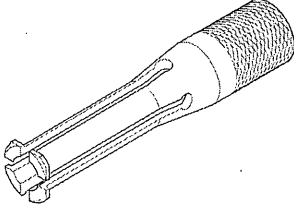
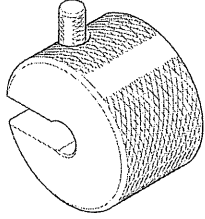
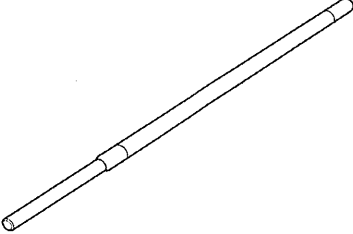
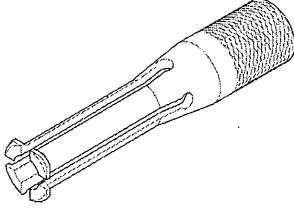
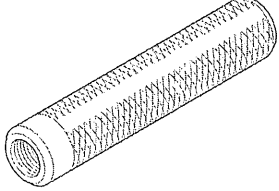
## REAR WHEEL/BRAKE/SUSPENSION

<p>Bearing remover shaft, 15 mm 07936-KC10100</p>  <p>(Not available in U.S.A.)</p>	<p>Bearing remover head, 14 mm 07WMC-KFG0100</p>  <p>(Not available in U.S.A.)</p>	<p>Remover weight 07741-0010201</p>  <p>or 07936-371020A (U.S.A. only)</p>
<p>Bearing remover shaft, 14 mm 07YMC-001010A (U.S.A. only)</p> 	<p>Bearing remover collet, 15 mm 07936-KC10200 (U.S.A. only)</p>  <p>(Collet only from 07936-KC10500)</p>	<p>Remover handle 07936-3710100</p> 
<p>Pilot, 20 mm 07746-0040500</p> 		

## TROUBLESHOOTING

### Rear wheel wobbles

- Bent rim
- Faulty tire
- Axle nut and/or engine mounting bolt/nut not tightened properly
- Loose or worn final gear shaft bearing
- Insufficient tire pressure

### Soft suspension

- Weak rear shock absorber spring
- Oil leakage from damper unit
- Low tire pressure

### Stiff suspension

- Bent damper rod
- High tire pressure

### Rear suspension noisy

- Loose mounting fasteners
- Faulty shock absorber
- Weak rear suspension bushings

## REAR WHEEL/SWINGARM

### REMOVAL

Remove the exhaust pipe/muffler (page 2-28).

Support the scooter on its centerstand and remove the following:

- Axle nut [1]
- Right rear shock absorber lower mounting bolt [2]

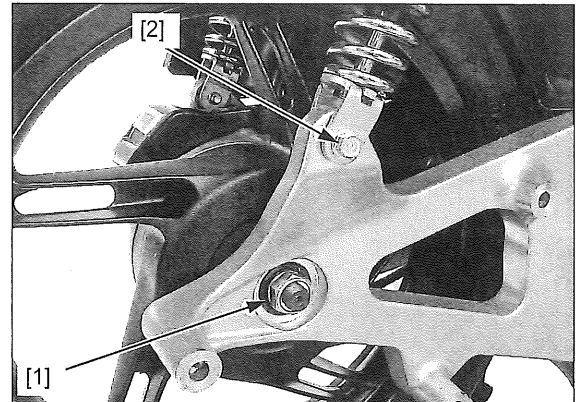

Remove the swingarm mounting bolts [1], washers [2] and swingarm [3].

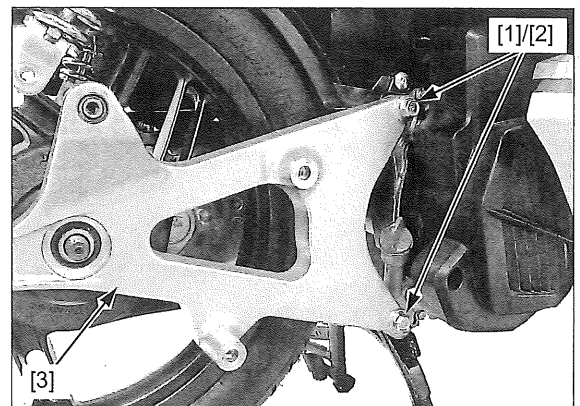

Remove the two socket bolts [1].

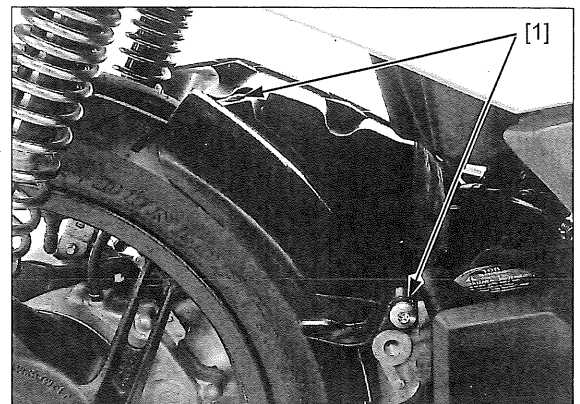

Slightly pull up the rear inner fender [1] and remove the rear wheel [2].

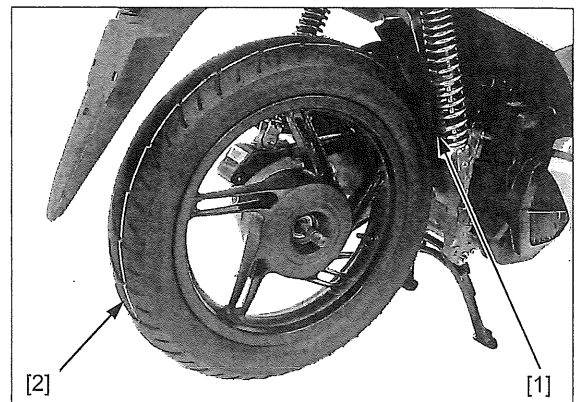

## REAR WHEEL/BRAKE/SUSPENSION

### INSTALLATION

Slightly pull up the rear inner fender [1] and install the rear wheel [2] onto the final gear shaft [3] by aligning the splines.

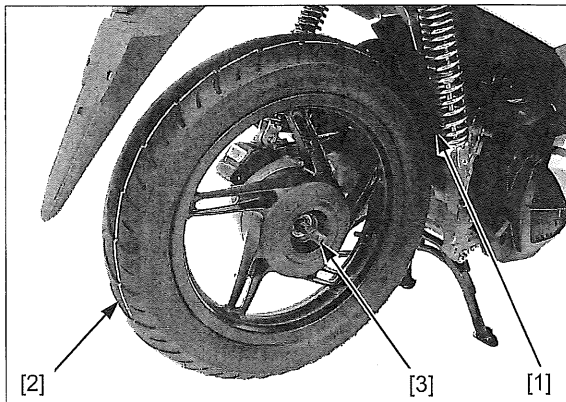

Set the rear inner fender [1] back in position.

Install and tighten the two socket bolts [2] to the specified torque.

#### TORQUE:

Engine side: 10 N·m (1.0 kgf·m, 7 lbf·ft)

Air cleaner side: 3.5 N·m (0.36 kgf·m, 2.6 lbf·ft)

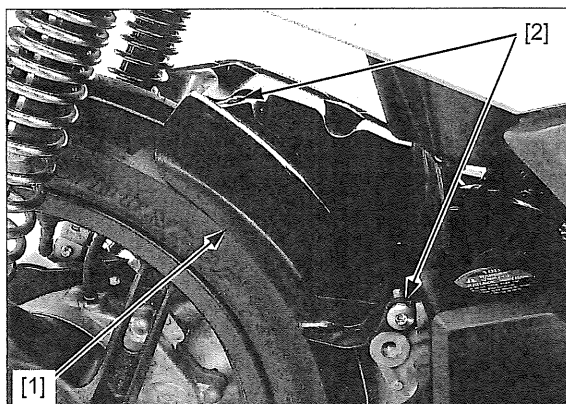

Apply 0.03 – 0.04 g of grease to the final gear shaft grease groove [1].

Apply grease to the swingarm bearing fitting area of the final gear shaft.

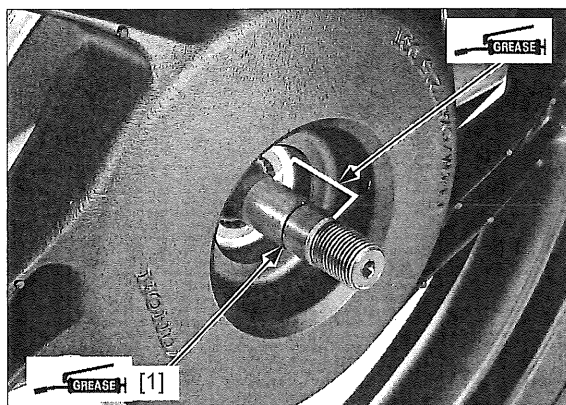

Install the swingarm [1] onto the final gear shaft.

Install the washers [2] and swingarm mounting bolts [3], then tighten them.

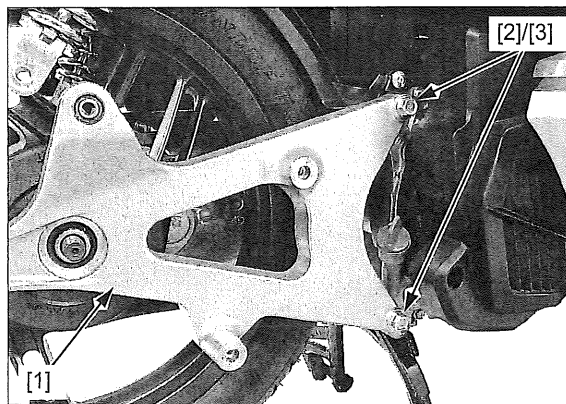



Install and tighten the right rear shock absorber lower mounting bolt [1].

Apply engine oil to the threads and seating surface of the rear axle nut [2].

Install the rear axle nut and tighten it to the specified torque.

**TORQUE: 118 N·m (12.0 kgf·m, 87 lbf·ft)**

Install the exhaust pipe/muffler (page 2-28).

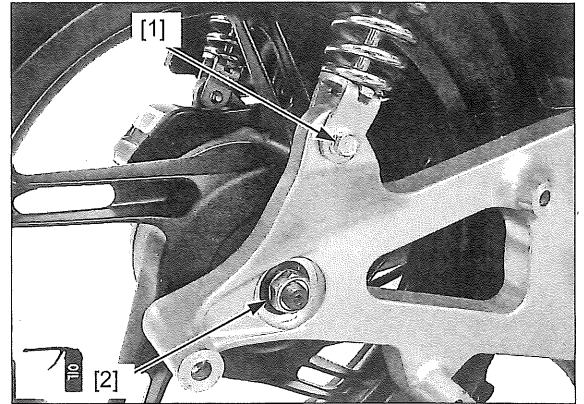

**WHEEL INSPECTION**

Check the wheel rim runout using dial indicators. Actual runout is 1/2 the total indicator readings.

**SERVICE LIMITS:**

**Radial: 2.0 mm (0.08 in)**

**Axial: 2.0 mm (0.08 in)**

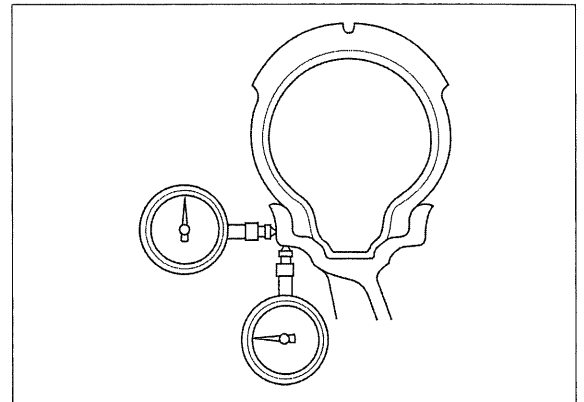

**SWINGARM BEARING INSPECTION/REPLACEMENT**

Remove the swingarm (page 18-5).

Remove the side collars [1] and dust seals [2] from the swingarm [3].

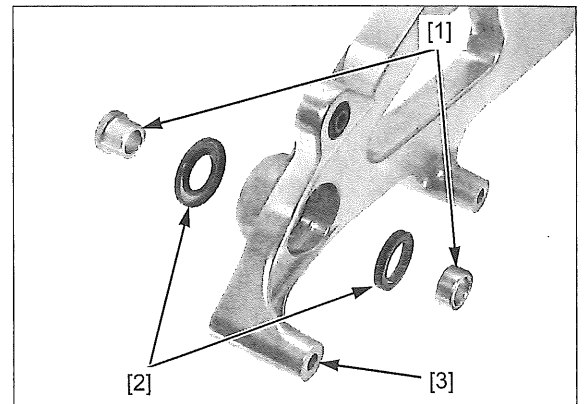

Turn the inner race of the bearing [1] with your finger.

The bearing should turn smoothly and quietly.

Also check that the bearing outer race fits tightly in the swingarm.

If the inner race does not turn smoothly and quietly or outer race fits loosely, replace the bearing in the following procedure.

Remove the snap ring [2].

Drive the bearing out from the swingarm.

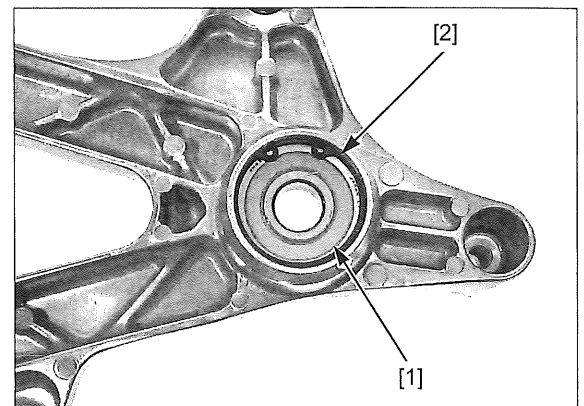

## REAR WHEEL/BRAKE/SUSPENSION

Drive in new bearing [1] squarely with the marked side facing up until it is fully seated.

### TOOL:

[2] Driver

07749-0010000

[3] Attachment, 37 x 40 mm

07746-0010200

[4] Pilot, 17 mm

07746-0040400

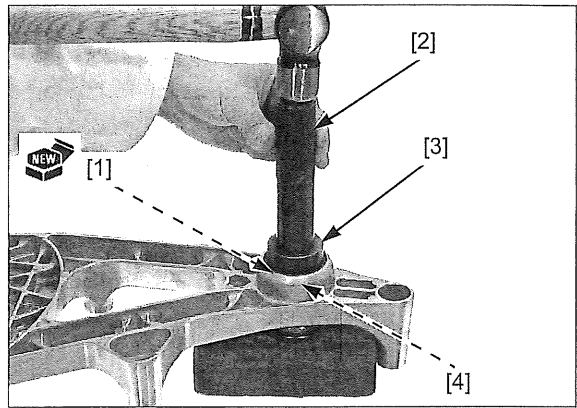

Install the snap ring [1] into the swingarm groove securely with the chamfered side facing the bearing.

Apply grease to the new dust seal [2] lips.

Install each dust seals until they are flush with the swingarm surfaces.

Install the swingarm (page 18-6).

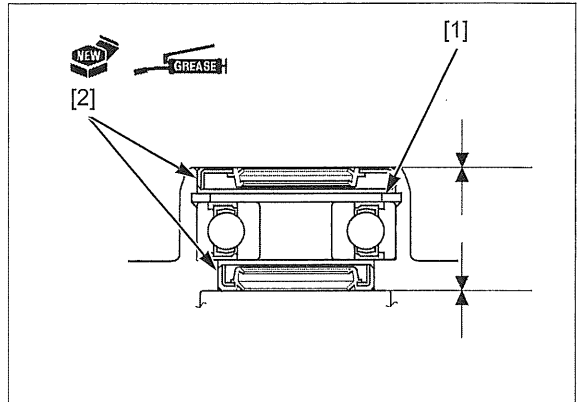

## REAR DRUM BRAKE

### INSPECTION

Remove the rear wheel (page 18-5)

Measure the rear brake drum I.D.

**SERVICE LIMIT: 131.0 mm (5.16 in)**

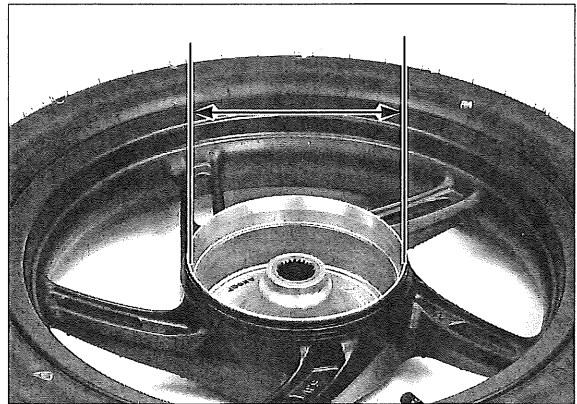

### DISASSEMBLY

Remove the rear wheel (page 18-5).

Remove the adjusting nut [1] and brake cable [2] from the joint pin [3].

Remove the joint pin and return spring [4].

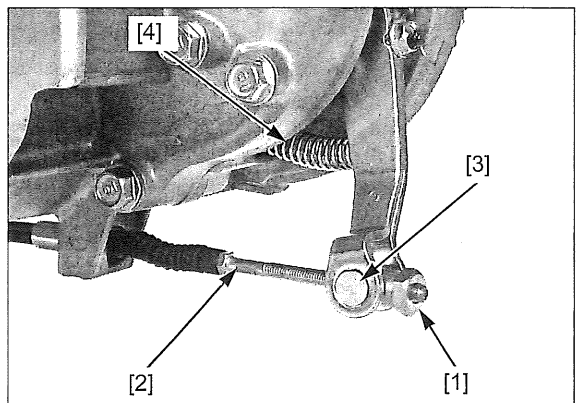

## REAR WHEEL/BRAKE/SUSPENSION

Mark all parts during disassembly so they can be placed back in the original locations.

Expand the brake shoes [1] and remove the brake shoes/shoe springs [2] from the brake panel.

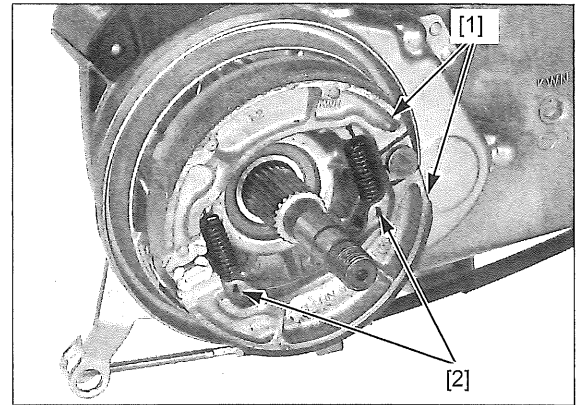

Remove the brake arm bolt [1].

Slightly pull out the brake cam [2] and remove the brake arm [3], then remove the brake arm.

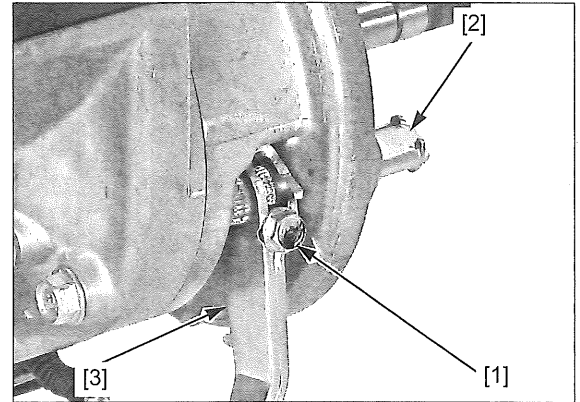

Remove both dust seals [1].

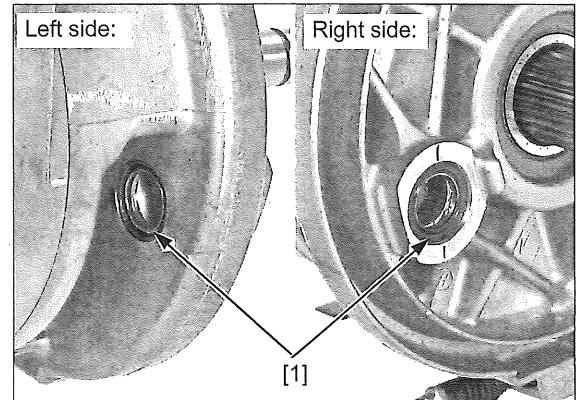

Remove the sleeve [1] using the special tools.

### TOOLS:

[2] Bearing remover shaft, 15 mm 07936-KC10100  
[3] Bearing remover head, 14 mm 07WMC-KFG0100  
[4] Remover weight 07741-0010201

### U.S.A. TOOLS:

Bearing remover shaft, 14 mm 07YMC-001010A  
Bearing remover collet, 15 mm 07936-KC10200  
(collet only from 07936-KC10500)  
Remover handle 07936-3710100  
Remover weight 07936-371020A

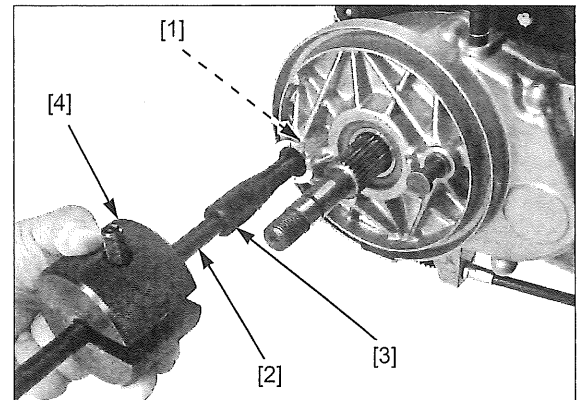

# REAR WHEEL/BRAKE/SUSPENSION ASSEMBLY

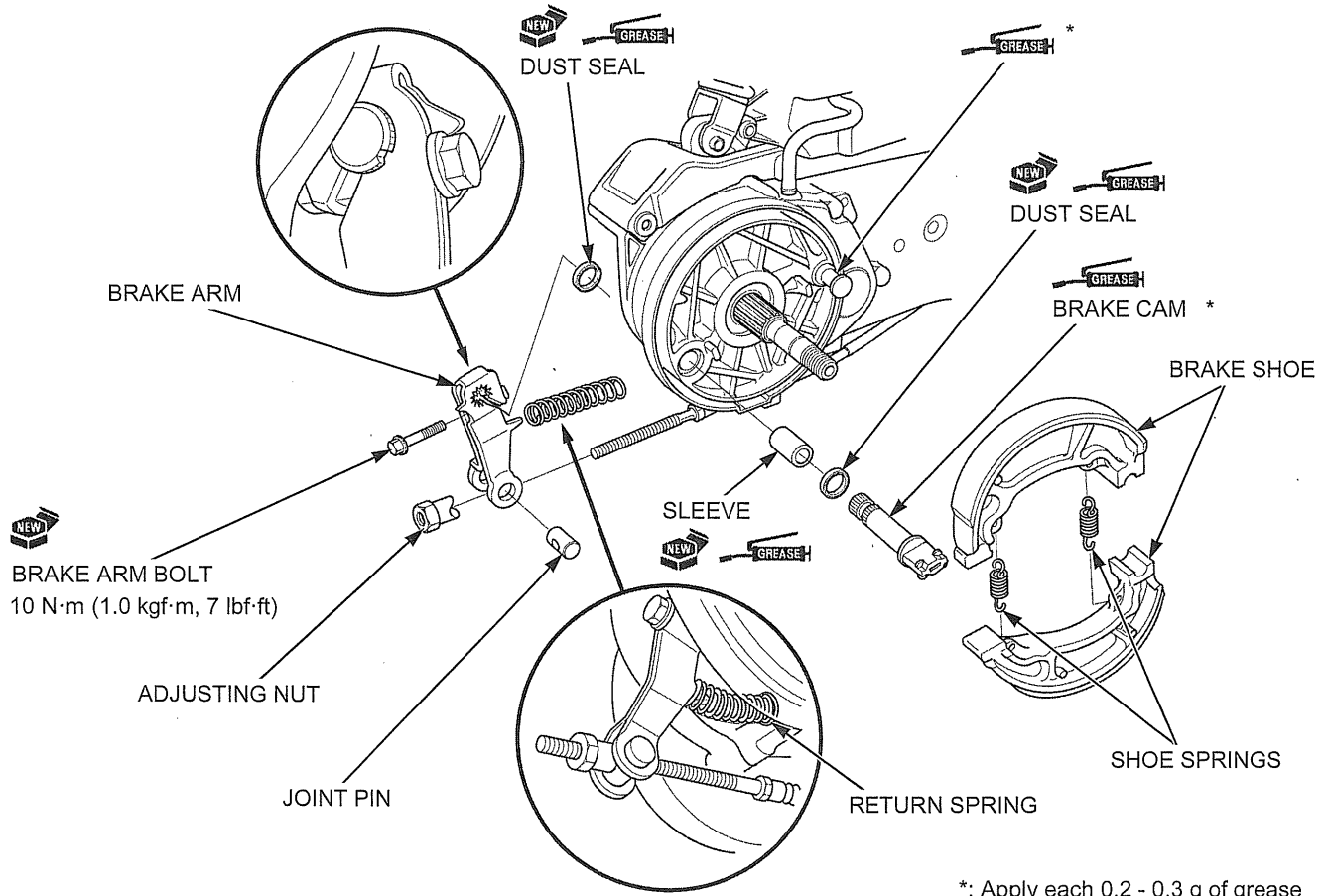

\*: Apply each 0.2 - 0.3 g of grease

Apply grease to a new sleeve [1] cavity.

Drive the sleeve so that the depth from the final reduction case surface is 4.3 - 4.9 mm (0.17 - 0.19 in), using the special tools.

**TOOLS:**

- [2] Driver
- [3] Pilot, 20 mm

07749-0010000  
07746-0040500

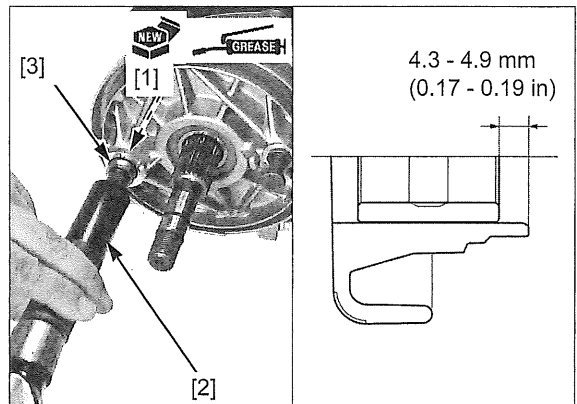

Apply grease to the both new dust seals.

Install the left dust seal [1] into the final reduction case until it is fully seated.

Install the right dust seal [2] so that the depth from the final reduction case surface is 0.5 - 1.1 mm (0.02 - 0.04 in).

- Install the dust seals in the correct direction as shown.

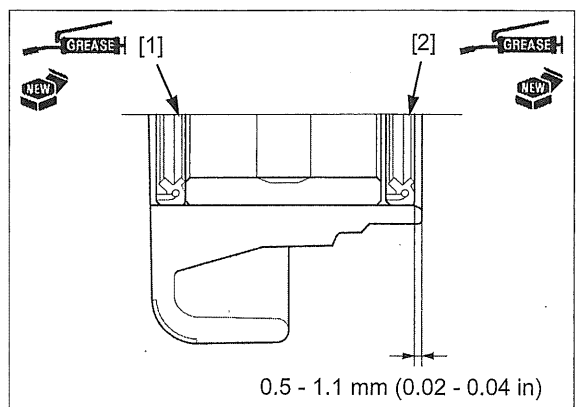

## REAR WHEEL/BRAKE/SUSPENSION

Apply 0.2 - 0.3 g of grease to the brake cam pivot area. Install the brake cam [1] and brake arm [2] by aligning the wide tooth of the brake cam with the groove of the brake arm.

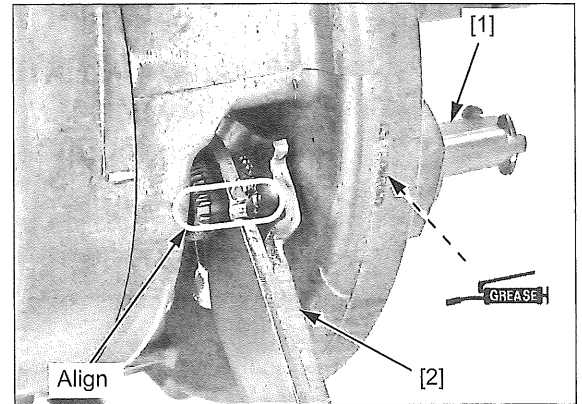

Install a new brake arm bolt [1] and tighten it to the specified torque.

**TORQUE: 10 N·m (1.0 kgf·m, 7 lbf·ft)**

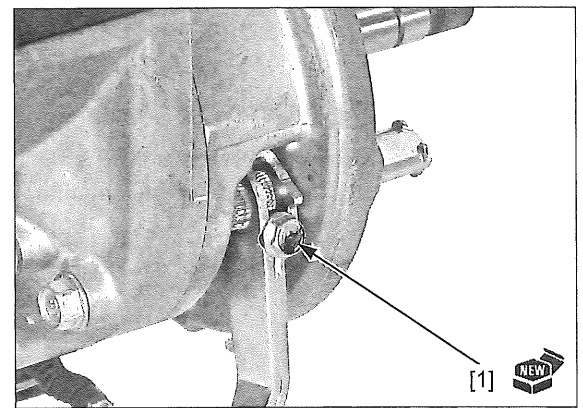

Apply 0.2 - 0.3 g grease to the anchor pin and brake cam sliding surface.

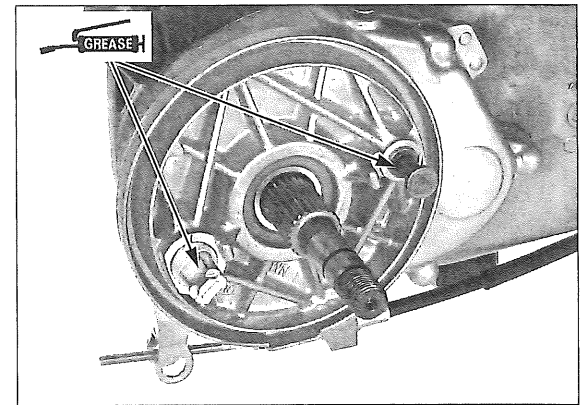

*Always replace the brake shoes as a set. When not replacing the brake shoes, install to the original direction.*

Assemble the brake shoes [1] and springs [2] in the direction as shown.

Wipe any excess grease from the brake cam and anchor pin.

Install the rear wheel (page 18-6).

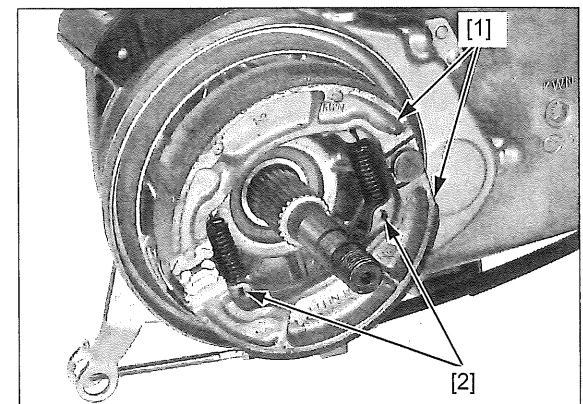

## REAR WHEEL/BRAKE/SUSPENSION

### REAR SHOCK ABSORBER

#### REMOVAL/INSTALLATION

To avoid damage to the rear shock absorber mounting bolt threads, slightly lift the rear wheel.

Remove the following:

- Luggage box (page 2-25)
- Lower mounting bolt [1]
- Upper mounting nut [2]
- Washers [3]
- Rear shock absorber [4]

Installation is in the reverse order of removal.

#### TORQUE:

**Shock absorber upper mounting nut:**  
24 N·m (2.4 kgf·m, 18 lbf·ft)

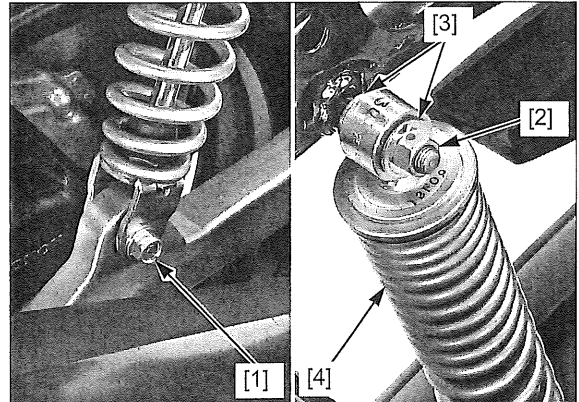

#### INSPECTION

Check the damper unit [1] for leakage or other damage.

Check the shock absorber bushing [2] for wear or damage.

Replace the shock absorber [3] if necessary.

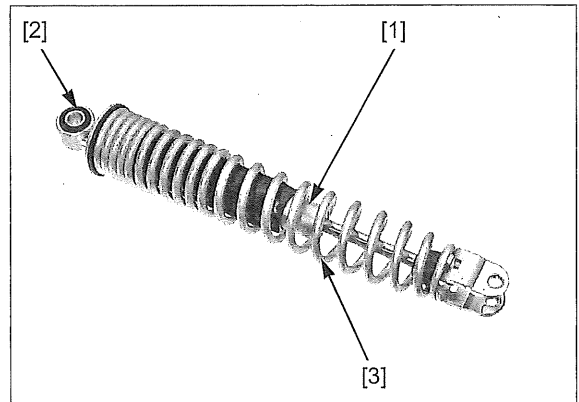

Check the rear shock absorber mount bushings [1] for wear or damage.

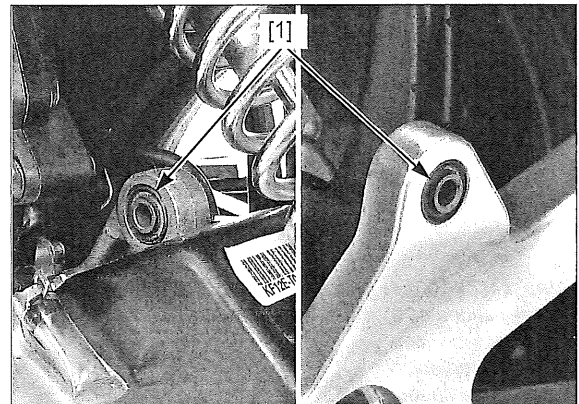

# 19. HYDRAULIC BRAKE

---

COMPONENT LOCATION .....	19-2	BRAKE PAD/DISC .....	19-10
SERVICE INFORMATION .....	19-3	BRAKE MASTER CYLINDER .....	19-12
TROUBLESHOOTING .....	19-4	CBS MASTER CYLINDER .....	19-16
BRAKE FLUID REPLACEMENT/ AIR BLEEDING .....	19-5	BRAKE CALIPER .....	19-23

# HYDRAULIC BRAKE

## COMPONENT LOCATION

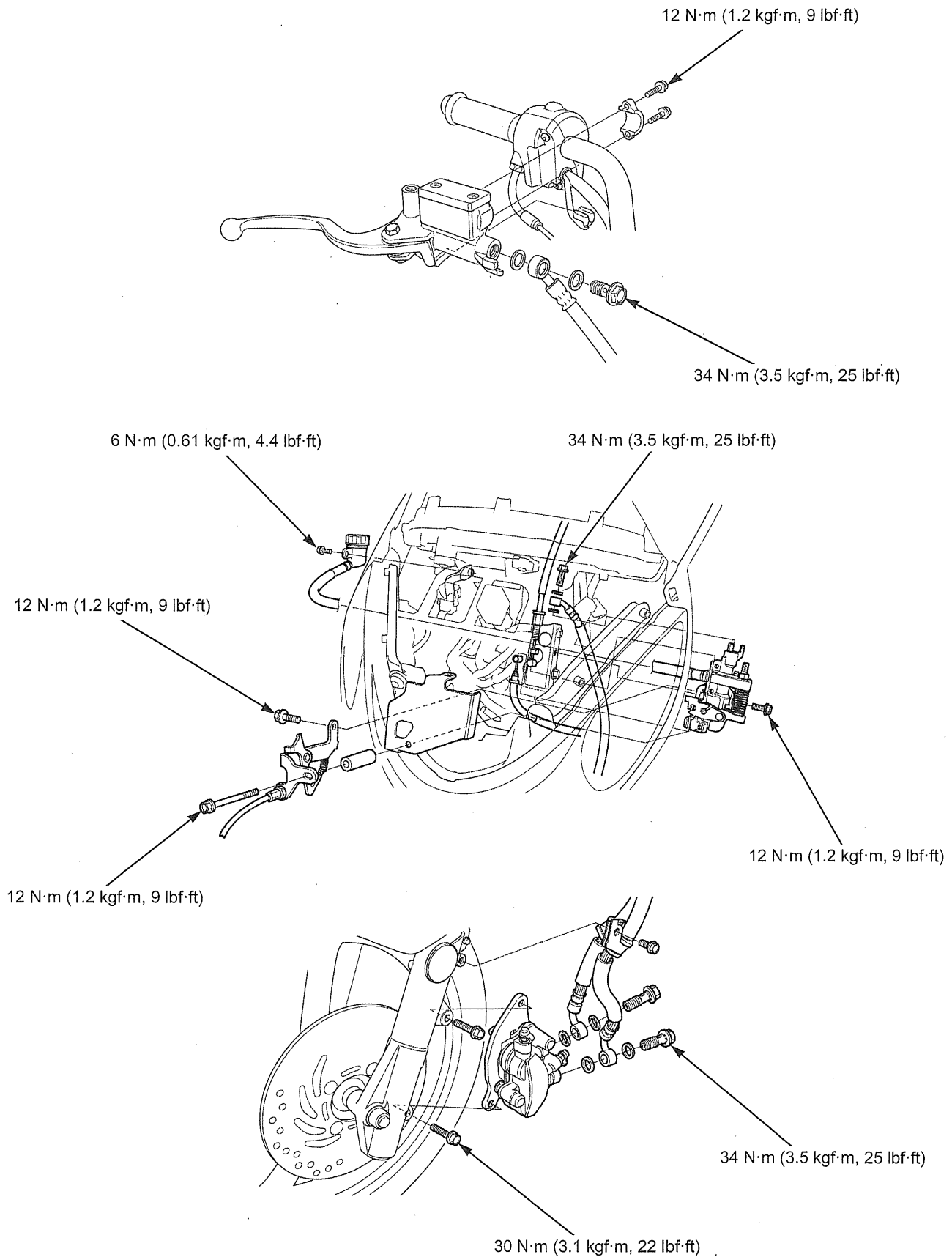



# SERVICE INFORMATION

## GENERAL

### ⚠ WARNING

Frequent inhalation of brake pad and shoe dust, regardless of material composition, could be hazardous to your health

- Avoid breathing dust particles.
- Never use an air hose or brush to clean brake assemblies. Use an OSHA-approved vacuum cleaner.

### NOTICE

Spilled brake fluid will severely damage instrument lenses and painted surfaces. It is also harmful to some rubber parts. Be careful whenever you remove the reservoir cap; make sure the master cylinder reservoir is horizontal first.

- A contaminated brake disc or pad reduces stopping power. Discard contaminated pads and clean a contaminated disc with a high quality brake degreasing agent.
- Check the brake system by applying the brake lever after the air bleeding.
- Never allow contaminants (dirt, water, etc.) to get into an open reservoir.
- Once the hydraulic system has been opened, or if the brake feels spongy, the system must be bled.
- Always use fresh DOT 3 or DOT 4 brake fluid from a sealed container when servicing the system. Do not mix different types of fluid, they may not be compatible.
- Always check brake operation before riding the scooter.

## SPECIFICATIONS

Unit: mm (in)

ITEM		STANDARD	SERVICE LIMIT
Specified brake fluid		DOT 3 or 4	—
Brake disc	Thickness	3.5 ± 0.2 (0.14 ± 0.008)	3.0 (0.12)
	Warpage	0.10 (0.004)	0.30 (0.001)
Front brake master cylinder	Cylinder I.D.	12.700 – 12.743 (0.5000 – 0.5017)	12.755 (0.5022)
	Piston O.D.	12.657 – 12.684 (0.4983 – 0.4994)	12.645 (0.4978)
CBS master cylinder	Cylinder I.D.	11.000 – 11.043 (0.4331 – 0.4348)	11.055 (0.4352)
	Piston O.D.	10.957 – 10.984 (0.4314 – 0.4324)	10.945 (0.4309)
Caliper	Cylinder I.D.	Upper	25.400 – 25.450 (1.0000 – 1.0020)
		Center/ lower	22.650 – 22.700 (0.8917 – 0.8937)
	Piston O.D.	Upper	25.318 – 25.368 (0.9968 – 0.9987)
		Center/ Lower	22.585 – 22.618 (0.8892 – 0.8905)
			25.460 (1.0024)
			22.710 (0.8941)
			25.31 (0.996)
			22.56 (0.888)

## TORQUE VALUES

ITEM	Q'TY	THREAD DIA. (mm)	TORQUE N·m (kgf·m, lbf·ft)	REMARKS
Brake caliper bleed valve	2	8	5.4 (0.55, 4.4)	
Front brake master cylinder reservoir cap screw	2	4	1.5 (0.15, 1.1)	
CBS master cylinder reservoir bolt	1	6	6 (0.61, 4.4)	
Front brake light switch screw	1	4	1 (0.1, 0.7)	
Brake pad pin	1	10	18 (1.8, 13)	
Front brake lever pivot bolt	1	6	1 (0.1, 0.7)	
Front brake lever pivot nut	1	6	6 (0.61, 4.4)	
Front master cylinder holder socket bolt	2	6	12 (1.2, 9)	
Brake hose oil bolt	4	10	34 (3.5, 25)	
Rearview mirror lock nut	2	10	34 (3.5, 25)	Left hand threads.
CBS master cylinder stay bolt	2	6	12 (1.2, 9)	
Knocker pivot screw	1	6	2.5 (0.26, 1.8)	Left hand threads.
Knocker pivot nut	1	6	10 (1.0, 7)	Left hand threads, U-nut
CBS master cylinder mounting bolt	2	6	12 (1.2, 9)	
CBS master cylinder cover bolt	1	6	12 (1.2, 9)	
Brake caliper mounting bolt	2	8	30 (3.1, 22)	ALOC bolt: replace with new ones.
Brake caliper torque pin	1	8	22 (2.2, 16)	
Brake caliper pin	1	8	18 (1.8, 13)	

# HYDRAULIC BRAKE

---

## TOOL

Snap ring pliers  
07914-SA50001

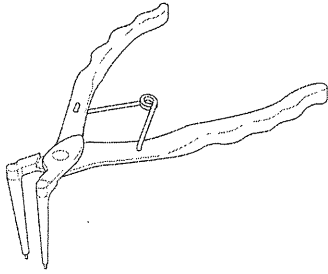

## TROUBLESHOOTING

### Poor rear brake performance

- Incorrect adjustment of rear brake lever
- Contaminated brake shoes
- Worn brake shoes
- Worn brake cam
- Worn brake drum
- Improperly installed brake arm
- Improperly engaged brake arm serrations

### Brake lever soft or spongy

- Air in hydraulic system
- Leaking hydraulic system
- Contaminated brake pad/disc
- Worn caliper piston seals
- Worn master cylinder piston cups
- Worn brake pad/disc
- Contaminated caliper
- Contaminated master cylinder
- Caliper not sliding properly
- Low brake fluid level
- Clogged fluid passage
- Warped/deformed brake disc
- Sticking/worn caliper piston
- Sticking/worn master cylinder piston
- Bent brake lever

### Brake lever hard

- Clogged/restricted brake system
- Sticking/worn caliper piston
- Caliper not sliding properly
- Worn caliper piston seal
- Sticking/worn master cylinder piston
- Bent brake lever

### Brake drags

- Contaminated brake pad/disc
- Misaligned wheel
- Badly worn brake pad/disc
- Warped/deformed brake disc
- Caliper not sliding properly
- Clogged/restricted fluid passage
- Sticking caliper piston
- Improperly adjusted equalizer (page 3-19)

# BRAKE FLUID REPLACEMENT/ AIR BLEEDING

## BRAKE FLUID DRAINING

### NOTICE

Spilled fluid can damage painted, plastic or rubber parts. Place a rag over these parts whenever the system is serviced.

- Do not mix different types of fluid, as they are not compatible with each other.
- Do not allow foreign material to enter the system when filling the reservoir.

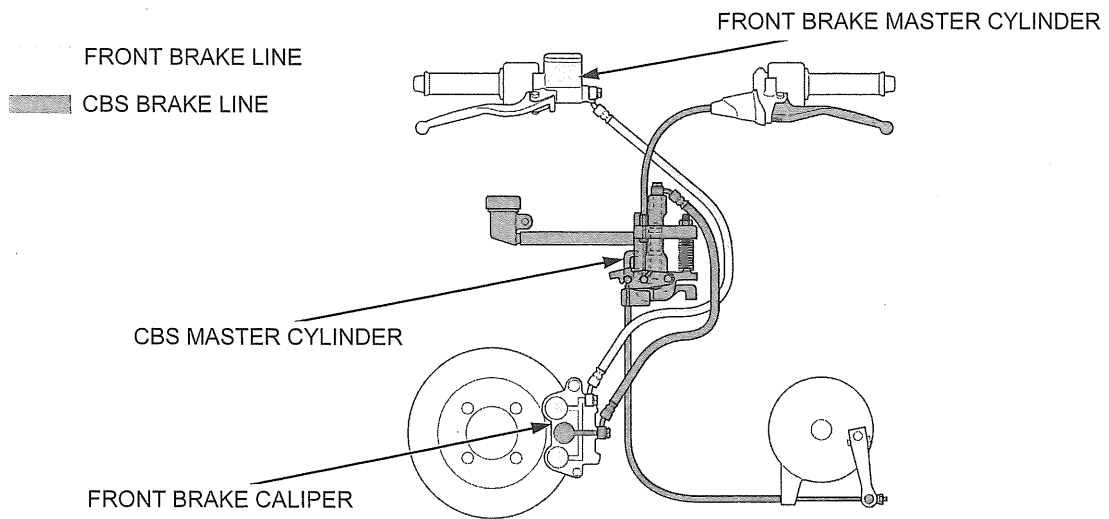

### FRONT BRAKE LINE

Turn the handlebar until the reservoir is parallel to the ground before removing the reservoir cap.

Remove the screws [1], reservoir cap [2], diaphragm plate [3] and diaphragm [4].

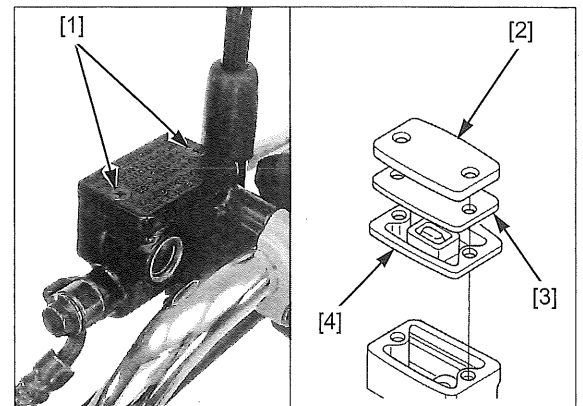

*Be careful not to confuse with the CBS brake line bleed valve.*

Connect a commercially available brake bleeder [1] to the front brake line bleed valve [2].

Loosen the bleed valve and operate the bleeder. Drain the brake fluid.

Tighten the front brake line bleed valve.

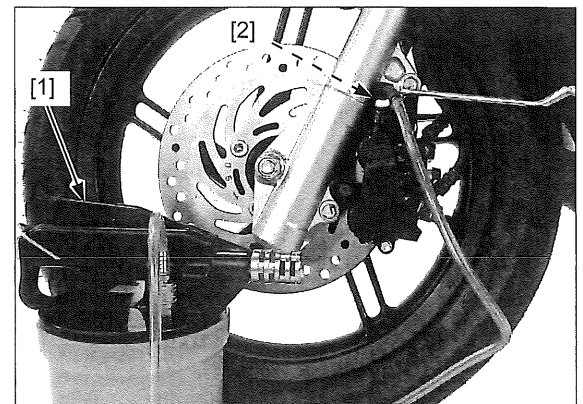

# HYDRAULIC BRAKE

## CBS BRAKE LINE

Remove the inner cover (page 2-13).

Remove the bolt [1] and CBS master cylinder reservoir [2].

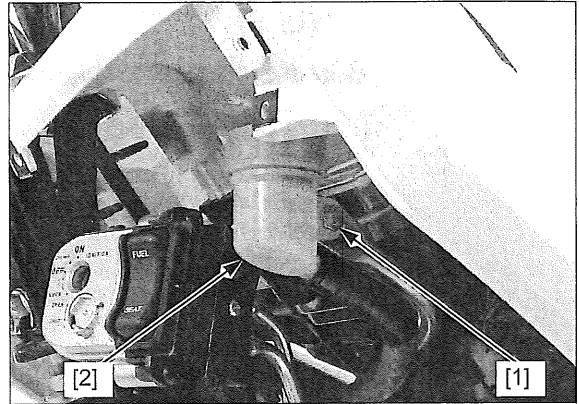

Pull out the CBS master cylinder reservoir as shown. Remove the reservoir cap [1], diaphragm plate [2] and diaphragm [3].

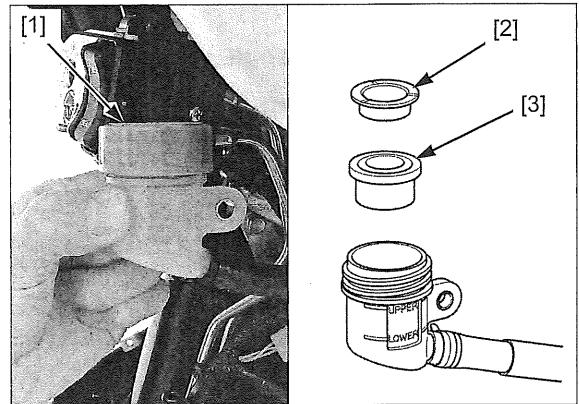

*Be careful not to confuse with the front brake line bleed valve.* Connect a commercially available brake bleeder [1] to the CBS brake line bleed valve [2]. Loosen the bleed valve and operate the bleeder. Drain the brake fluid.

Tighten the CBS brake line bleed valve.

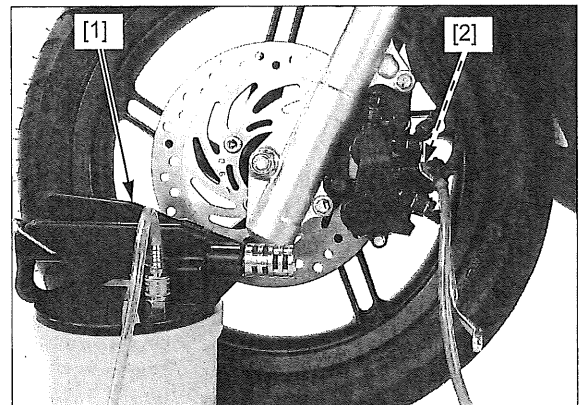

**BRAKE FLUID FILLING/AIR BLEEDING****FRONT BRAKE LINE**

- Use only DOT 3 or DOT 4 brake fluid from a sealed container.
- Do not mix different types of fluid. They are not compatible.

*Be careful not to confuse with the CBS brake line bleed valve.*

Fill the master cylinder reservoir with DOT 3 or DOT 4 brake fluid from the sealed container to the upper level.

Connect a commercially available brake bleeder [1] to the front brake line bleed valve [2].

Operate the brake bleeder and loosen the front brake line bleed valve.

- If an automatic refill system is not used, add brake fluid when the fluid level in the reservoir is low.
- Check the fluid level often while bleeding the brake to prevent air from being pumped into the system.
- When using a brake bleeder, follow the manufacturer's operating instructions.
- If air is entering the bleeder around the bleed valve threads, seal the threads with teflon tape.

Close the bleed valve.

Perform the bleeding procedure until the system is completely bled.

After bleeding the system completely, tighten the front brake line bleed valve to the specified torque.

**TORQUE: 5.4 N·m (0.55 kgf·m, 4.4 lbf·ft)**

If the brake bleeder is not available, perform the following procedure.

Fill the master cylinder reservoir with DOT 3 or DOT 4 brake fluid from the sealed container to the upper level.

Pump up the system pressure with the brake lever until the lever resistance is felt.

Connect a bleed hose [1] to the bleed valve [2] and bleed the system as follows:

- Do not release the brake lever until the bleed valve has been closed.
  - Check the fluid level often while bleeding the brake to prevent air from being pumped into the system.
1. Squeeze the brake lever all the way and loosen the bleed valve 1/2 of a turn. Wait several seconds and then close the bleed valve.
  2. Release the brake lever slowly and wait several seconds after it reaches the end of its travel.
  3. Repeat the steps 1 and 2 until there are no air bubbles in the bleed hose.

After bleeding the system completely, tighten the bleed valve to the specified torque.

**TORQUE: 5.4 N·m (0.55 kgf·m, 4.4 lbf·ft)**

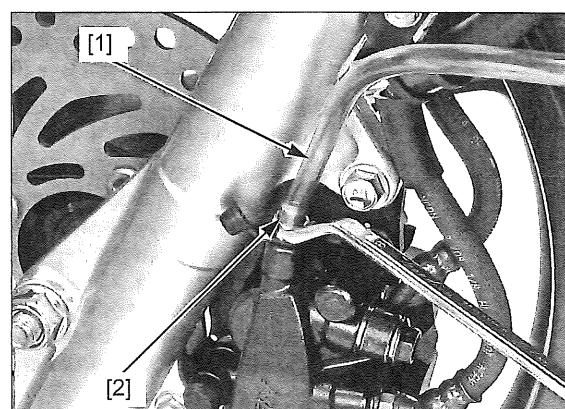
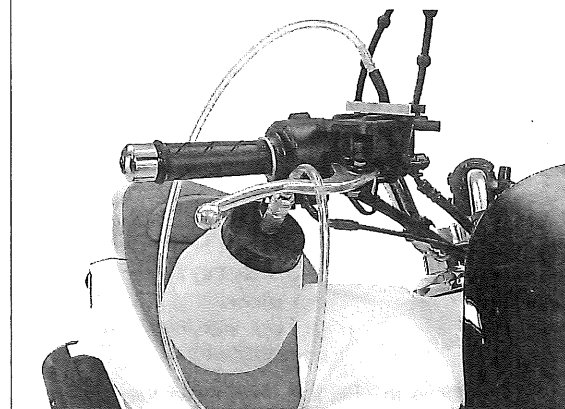
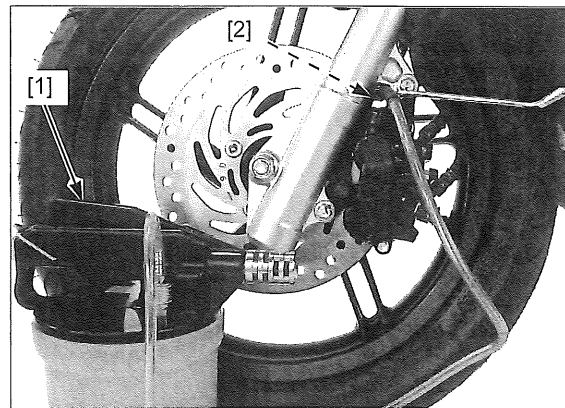

## HYDRAULIC BRAKE

Fill the reservoir to the upper level [1] with DOT 3 or DOT 4 brake fluid from a sealed container.

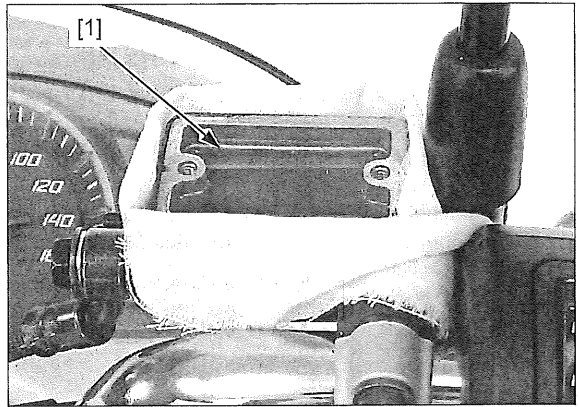

Install the diaphragm [1], diaphragm plate [2] and reservoir cap [3], then tighten the screws [4] to the specified torque.

**TORQUE: 1.5 N·m (0.15 kgf·m, 1.1 lbf·ft)**

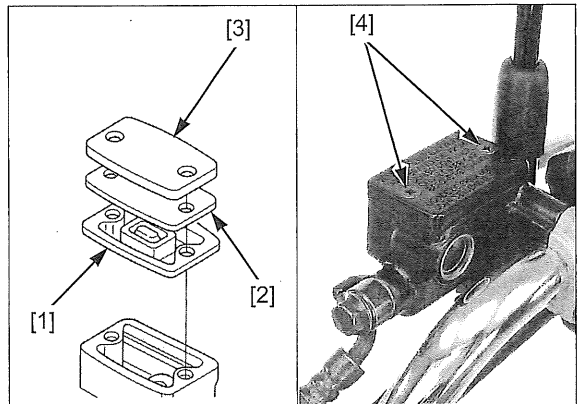

### CBS BRAKE LINE

- Use only DOT 3 or DOT 4 brake fluid from a sealed container.
- Do not mix different types of fluid. They are not compatible.

*Be careful not to confuse with the front brake line bleed valve.*

Fill the master cylinder reservoir with DOT 3 or DOT 4 brake fluid from the sealed container to the upper level.

Connect a commercially available brake bleeder [1] to the CBS brake line bleed valve [2].

Operate the brake bleeder and loosen the CBS brake line bleed valve.

- If an automatic refill system is not used, add brake fluid when the fluid level in the reservoir is low.
- Check the fluid level often while bleeding the brake to prevent air from being pumped into the system.
- When using a brake bleeder, follow the manufacturer's operating instructions.
- If air is entering the bleeder around the bleed valve threads, seal the threads with teflon tape.

Close the bleed valve.

Perform the bleeding procedure until the system is completely bled.

After bleeding the system completely, tighten the CBS brake line bleed valve to the specified torque.

**TORQUE: 5.4 N·m (0.55 kgf·m, 4.4 lbf·ft)**

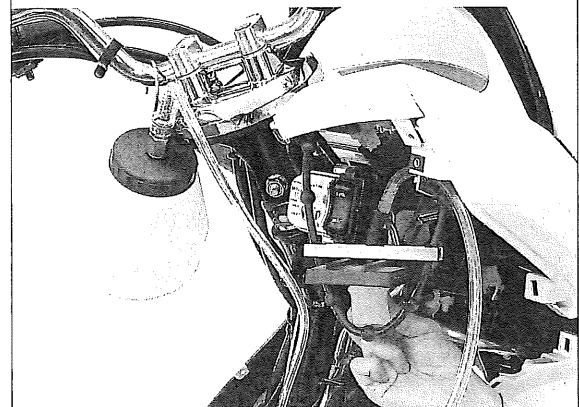
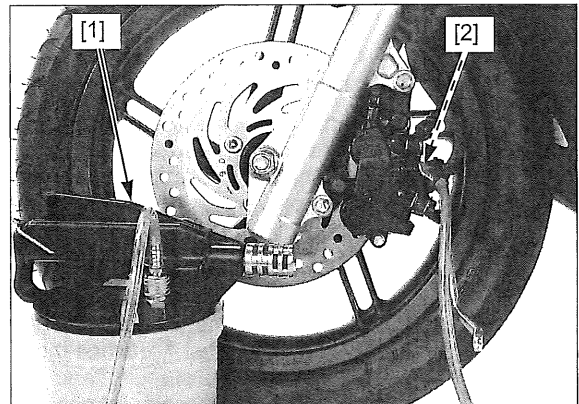

If the brake bleeder is not available, perform the following procedure.

Fill the master cylinder reservoir with DOT 3 or DOT 4 brake fluid from the sealed container to the upper level.

Pump up the system pressure with the knocker arm [1] until the arm resistance is felt.

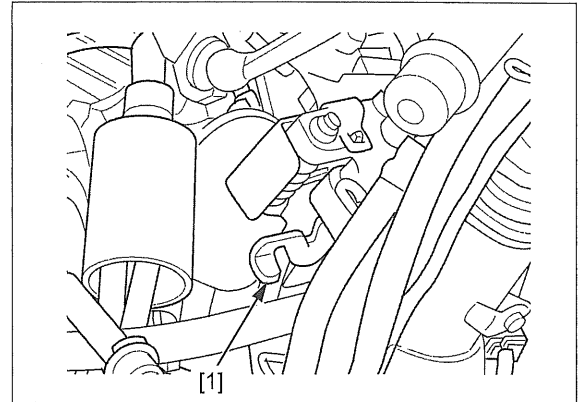

Connect a bleed hose [1] to the bleed valve [2] and bleed the system as follows:

- Do not release the knocker arm until the bleed valve has been closed.
  - Check the fluid level often while bleeding the brake to prevent air from being pumped into the system.
1. Push the knocker arm all the way and loosen the bleed valve 1/2 of a turn. Wait several seconds and then close the bleed valve.
  2. Release the knocker arm slowly and wait several seconds after it reaches the end of its travel.
  3. Repeat the steps 1 and 2 until there are no air bubbles in the bleed hose.

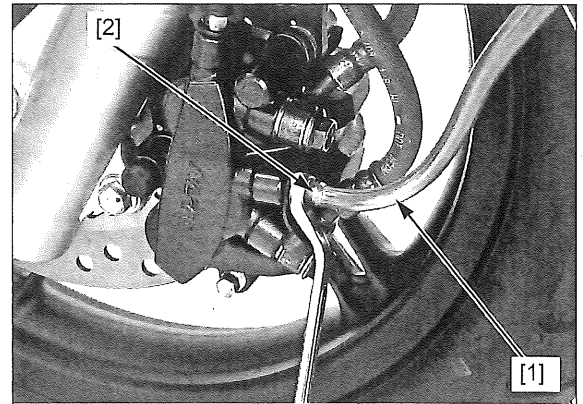

After bleeding the system completely, tighten the bleed valve to the specified torque.

**TORQUE: 5.4 N·m (0.55 kgf·m, 4.4 lbf·ft)**

Fill the reservoir to the upper level [1] with DOT 3 or DOT 4 brake fluid from a sealed container.

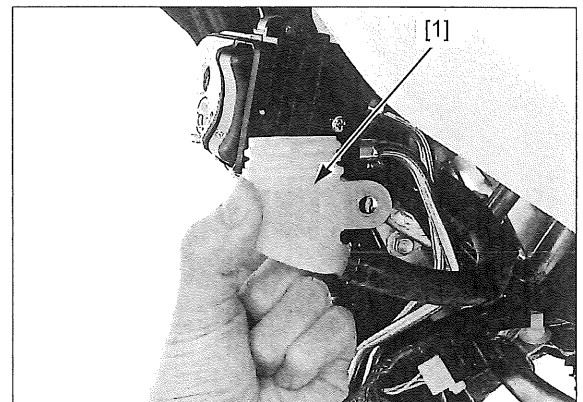

Install the diaphragm [1], diaphragm plate [2] and reservoir cap [3] securely.

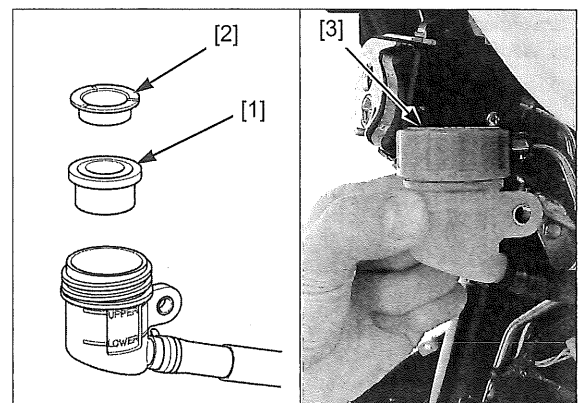



## HYDRAULIC BRAKE

Install the CBS master cylinder reservoir [1] and bolt [2], then tighten the bolt to the specified torque.

**TORQUE: 6 N·m (0.61 kgf·m, 4.4 lbf·ft)**

Install the inner cover (page 2-13).

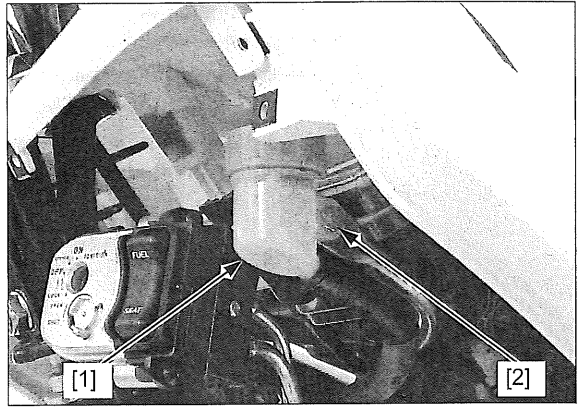

## BRAKE PAD/DISC

### BRAKE PAD REPLACEMENT

Remove the pad pin [1] from the brake caliper.

Remove the O-ring [2] from the pad pin.

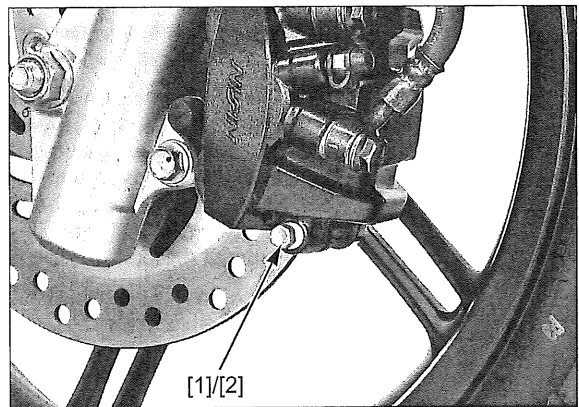

Remove the brake pads [1] from the brake caliper.

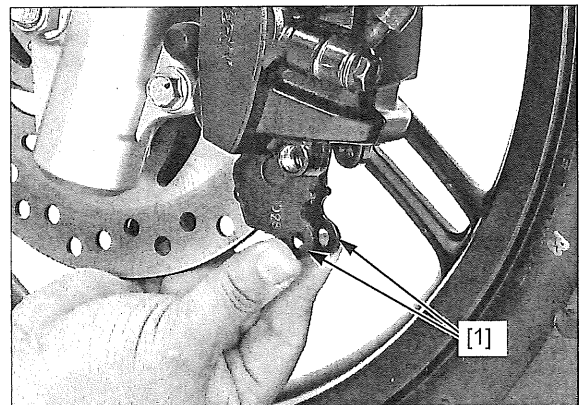

*Always replace the brake pads in pairs to assure even disc pressure.*

Install new brake pads [1] so that they are set on the brake caliper bracket and bracket pin [2].

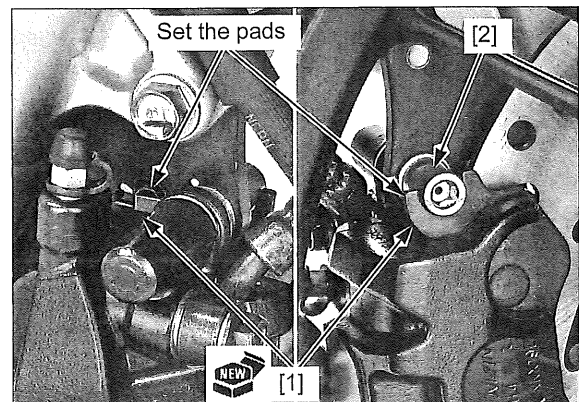



Apply silicon grease to the new O-ring [1] and install it to the pad pin [2].

Install the pad pin by pushing the brake pads against the pad spring to align the pad pin holes on the pads and caliper hole.

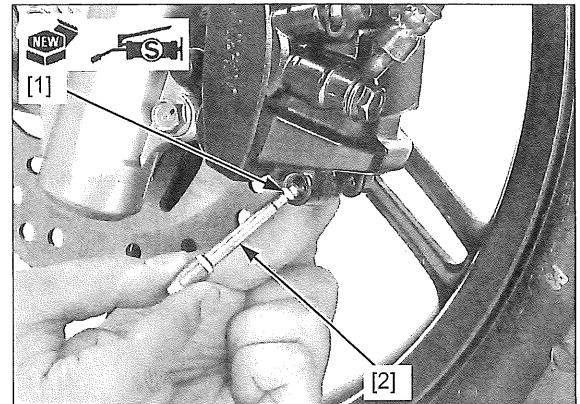

*After brake pad replacement, check the brake operation by applying the brake lever.*

Tighten the pad pin [1] to the specified torque.

**TORQUE: 18 N·m (1.8 kgf·m, 13 lbf·ft)**

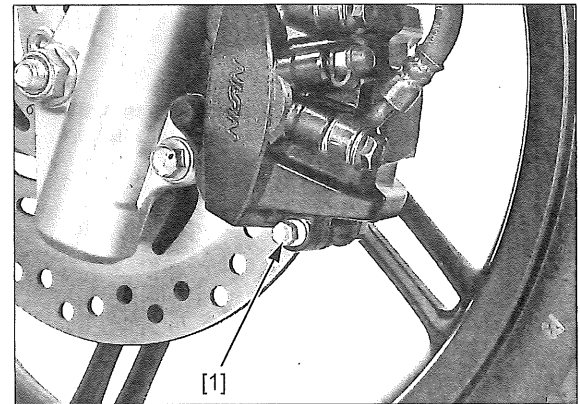

## BRAKE DISC INSPECTION

Visually inspect the brake disc for damage or cracks.

Measure the brake disc thickness at several points.

**SERVICE LIMIT: 3.0 mm (0.12 in)**

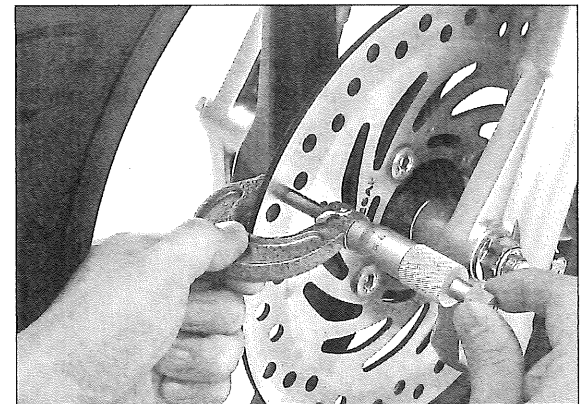

Check the brake disc for warpage.

**SERVICE LIMIT: 0.30 mm (0.001 in)**

If the warpage exceeds the service limit, check the wheel bearings for excessive play.

For brake disc replacement (page 17-7).

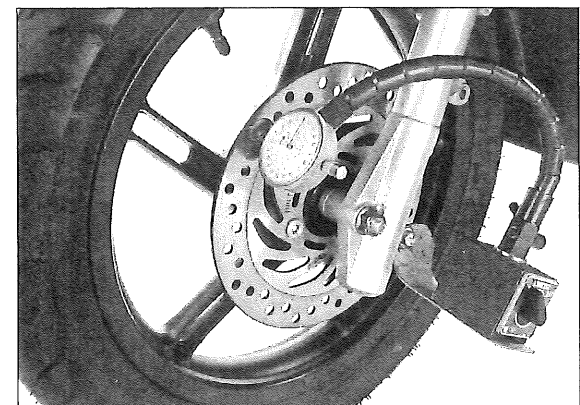

## HYDRAULIC BRAKE

### BRAKE MASTER CYLINDER

#### REMOVAL

Drain the brake fluid from the front brake line hydraulic system (page 19-5).

Remove the right rearview mirror [1].

Disconnect the front brake light switch connectors [2].

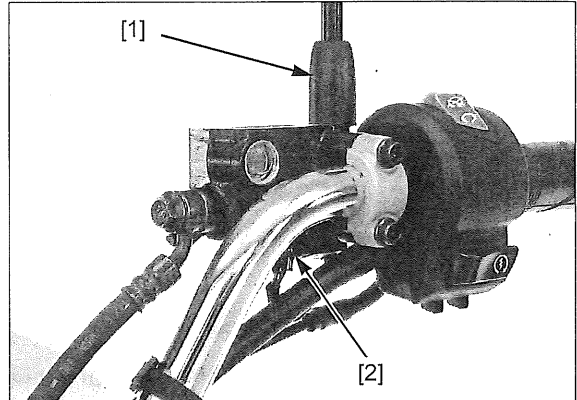

*When removing the brake hose oil bolt, cover the end of the hose to prevent contamination. Secure the hose to prevent the fluid from leaking out.*

Remove the brake hose oil bolt [1], sealing washers [2] and brake hose [3] eyelet.

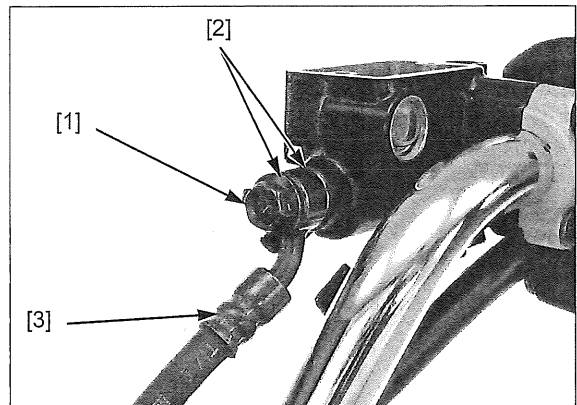

Remove the master cylinder holder socket bolts [1], holder [2] and master cylinder [3].

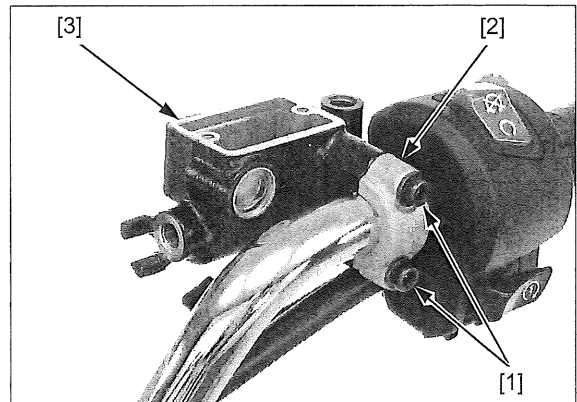

#### DISASSEMBLY

Remove the pivot nut [1], pivot bolt [2] and brake lever [3].

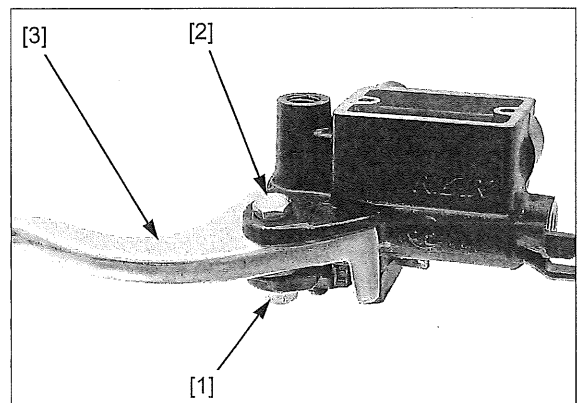

Remove the screw [1] and brake light switch [2].

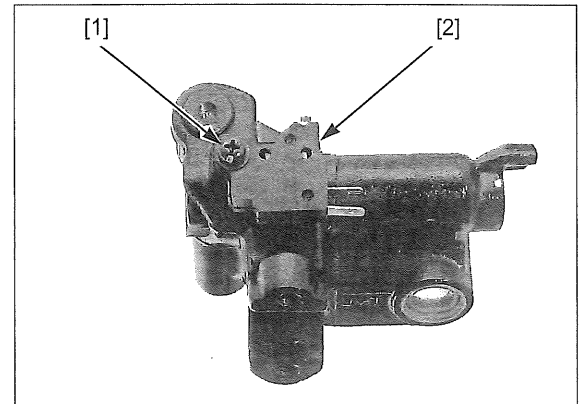

Remove the piston boot [1] from the front brake master cylinder and master piston.

Remove the snap ring [2] using the special tool.

**TOOL:**

[3] Snap ring pliers

07914-SA50001

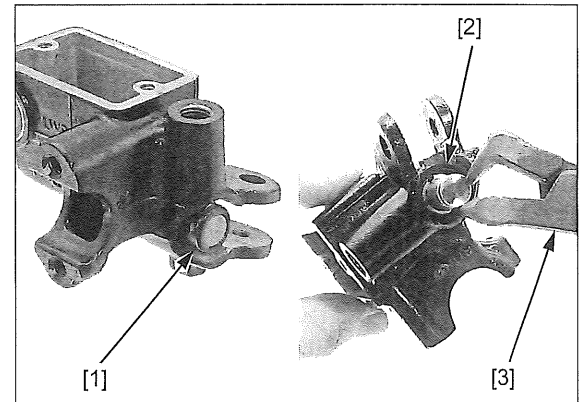

Remove the master piston [1] and spring [2].

Clean the master cylinder, reservoir and master piston.

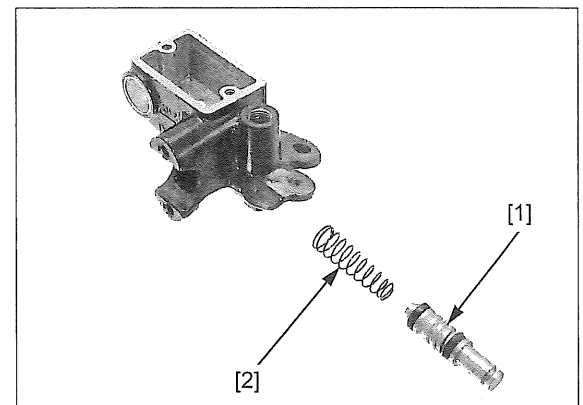

## INSPECTION

Check the piston cups for wear, deterioration or damage.

Check the master cylinder inner surface and piston outer surface for scratches or damage.

Measure the master cylinder I.D.

**SERVICE LIMIT: 12.755 mm (0.5022 in)**

Measure the master piston O.D.

**SERVICE LIMIT: 12.645 mm (0.4978 in)**

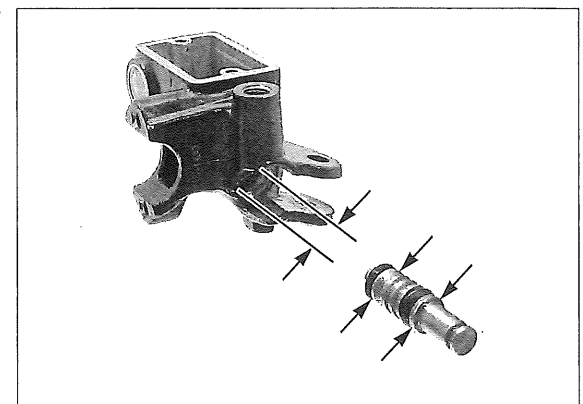

# HYDRAULIC BRAKE

## ASSEMBLY

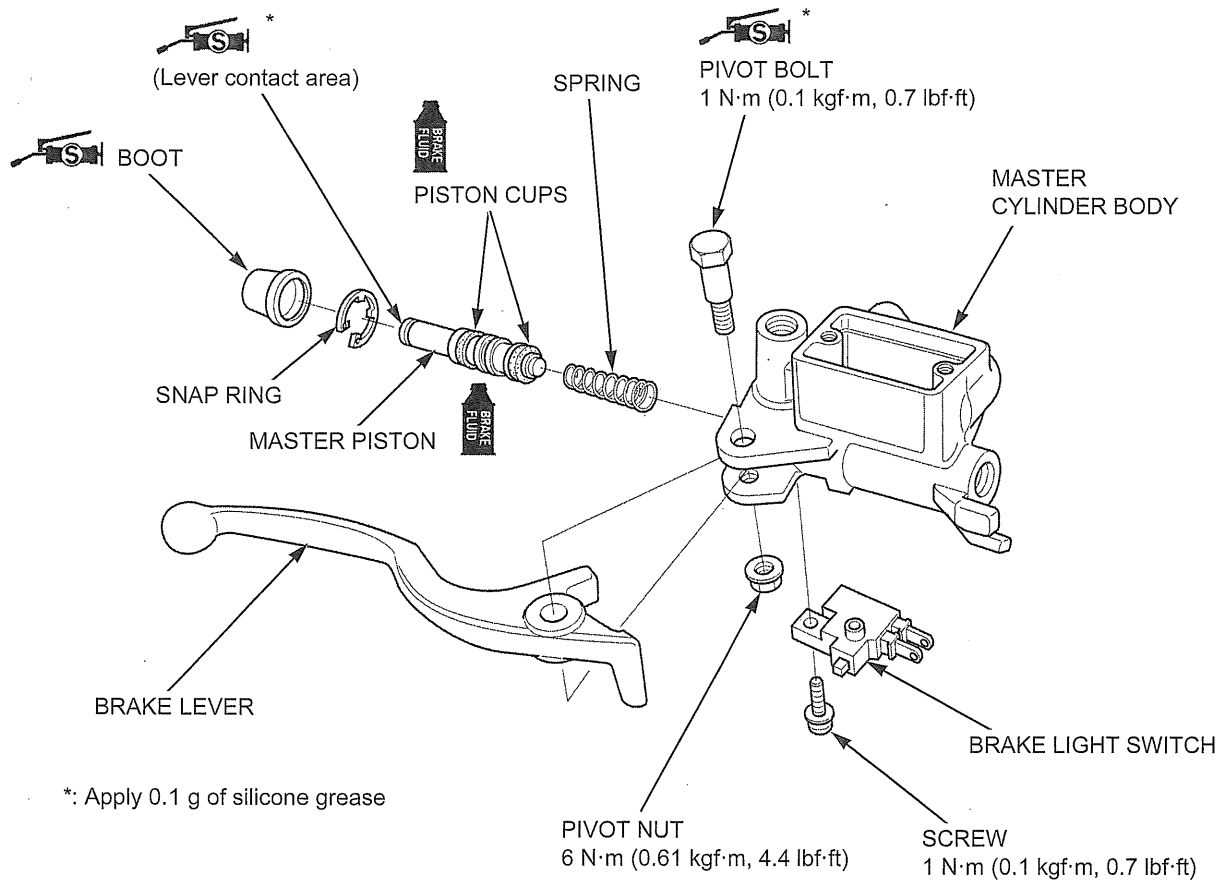

\*: Apply 0.1 g of silicone grease

Keep the piston, cups, spring, snap ring and boot as a set; do not substitute individual parts.

Coat the master piston [1] and piston cups [2] with clean DOT 3 or DOT 4 brake fluid.

Install the spring [3] onto the master piston.

*Do not allow the piston cup lips to turn inside out.*

Install the spring and master piston into the master cylinder.

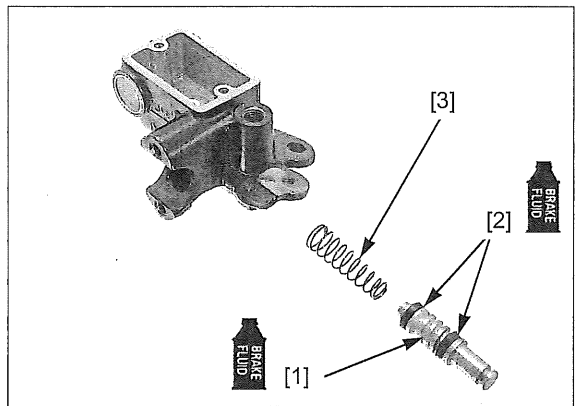

*Be sure that snap ring is firmly seated in the groove.*

Install the snap ring [1] into the groove in the master cylinder.

**TOOL:**

[2] Snap ring pliers **07914-SA50001**

Apply silicon grease to the inside of the piston boot [3].

Install the piston boot into the master cylinder and groove in the piston.

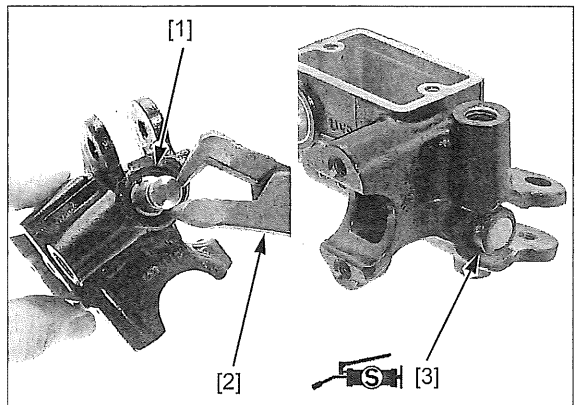

Install the brake light switch [1] by aligning the boss of the switch body and hole of the master cylinder. Install and tighten the screw [2] to the specified torque.

**TORQUE: 1 N·m (0.1 kgf·m, 0.7 lbf·ft)**

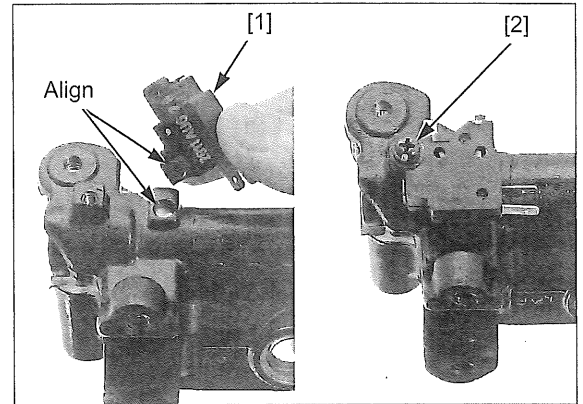

Apply 0.1 g of silicone grease to the contact surfaces of the brake lever [1], piston tip and brake lever pivot bolt [2] sliding surface. Install the brake lever.

Install the pivot bolt and tighten it to the specified torque.

**TORQUE: 1 N·m (0.1 kgf·m, 0.7 lbf·ft)**

Install the pivot nut [3] and tighten it to the specified torque while holding the pivot bolt.

**TORQUE: 6 N·m (0.61 kgf·m, 4.4 lbf·ft)**

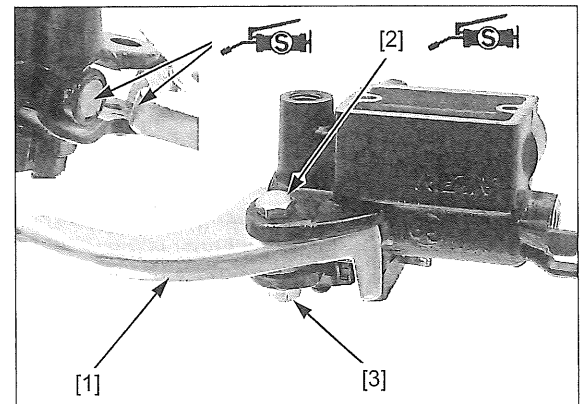

## INSTALLATION

Install the master cylinder [1] and holder [2] with the "UP" mark [3] facing up.

Align the end of the master cylinder with the punch mark [4] on the handlebar and tighten the upper bolt [5] first then tighten the lower bolt [6] to the specified torque.

**TORQUE: 12 N·m (1.2 kgf·m, 9 lbf·ft)**

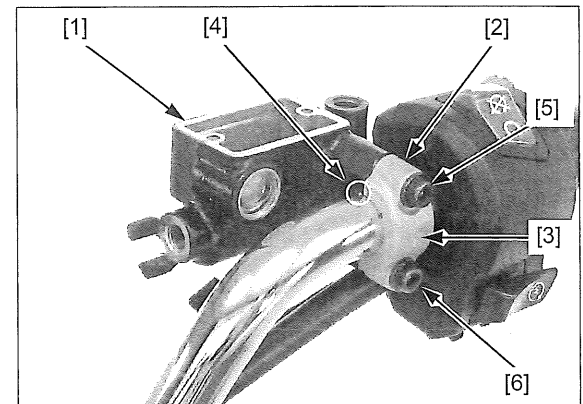

Connect the brake hose [1] with the oil bolt [2] and new sealing washers [3].

Set the brake hose joint onto the stopper [4] of the master cylinder then tighten the oil bolt to the specified torque.

**TORQUE: 34 N·m (3.5 kgf·m, 25 lbf·ft)**

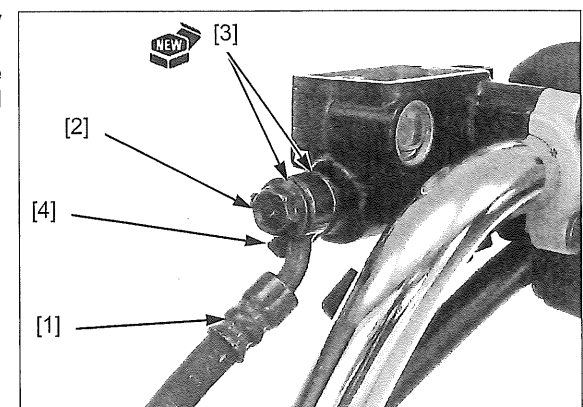

## HYDRAULIC BRAKE

Connect the brake light switch connectors [1].

*The rearview mirror lock nuts have left hand threads.*

Install the right rearview mirror [2] and tighten the lock nut to the specified torque.

**TORQUE: 34 N·m (3.5 kgf·m, 25 lbf·ft)**

Fill brake fluid and bleed air from the front brake line hydraulic system (page 19-7).

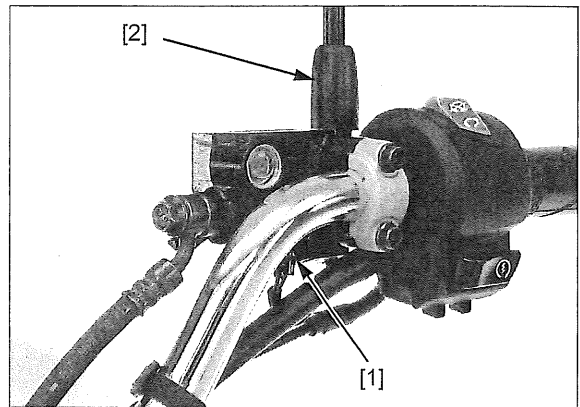

## CBS MASTER CYLINDER

### REMOVAL

Drain the brake fluid from the CBS brake line hydraulic system (page 19-6).

Remove the following:

- Inner cover (page 2-13)
- Front meter panel (page 2-7)

Loosen the adjusting nut [1] to the maximum.

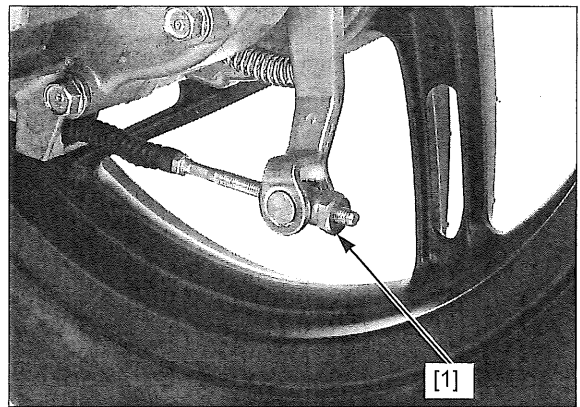

*When removing the brake hose oil bolt, cover the end of the hose to prevent contamination. Secure the hose to prevent the fluid from leaking out.*

Remove the brake hose oil bolt [1], sealing washers [2] and brake hose [3] eyelet.

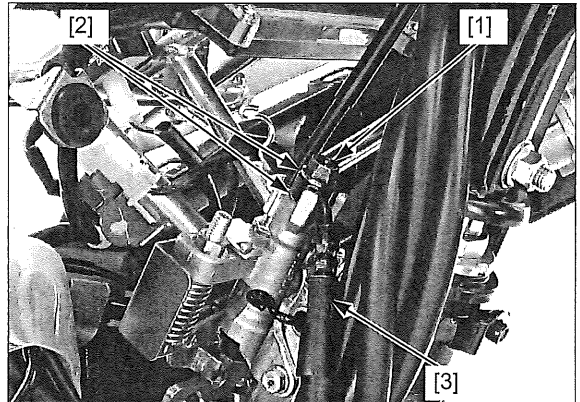

Remove the bolt [1], collar [2] and CBS master cylinder cover [3].

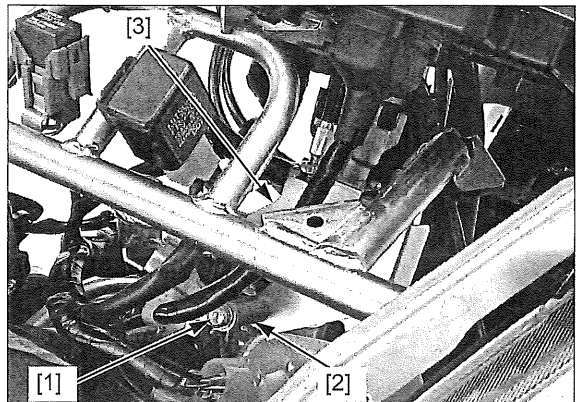

Remove the bolt [1] and brake lock stay [2].

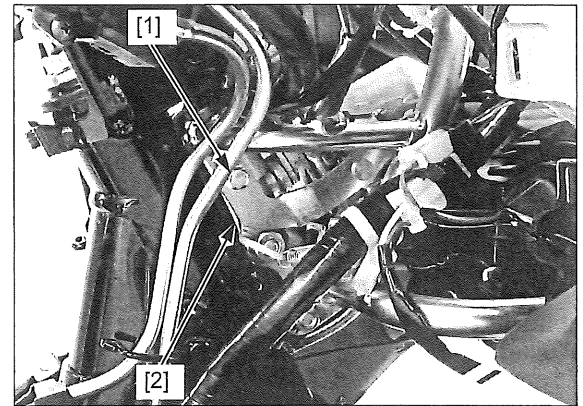

Release the 2nd rear brake cable [1] from the equalizer [2] and cable guide [3].

Loosen the lock nut [4] and adjuster [5].  
Release the 1st rear brake cable [6] from the equalizer.

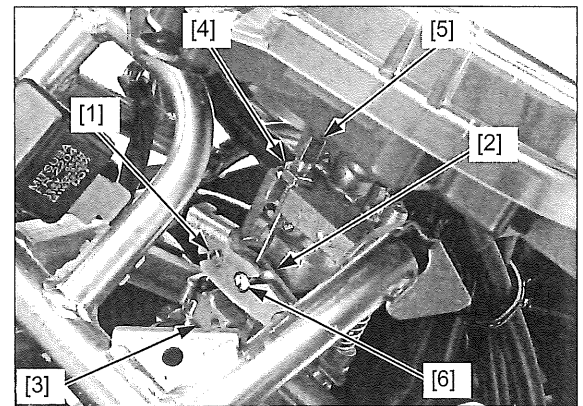

Remove the bolt [1] and CBS master cylinder [2].

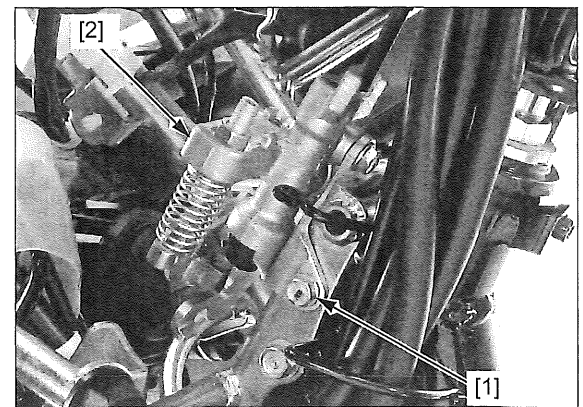

## DISASSEMBLY

Remove the snap ring [1] and reservoir hose joint [2] from the CBS master cylinder.

### TOOL:

Snap ring pliers

07914-SA50001

Remove the O-ring [3] from the reservoir hose joint.

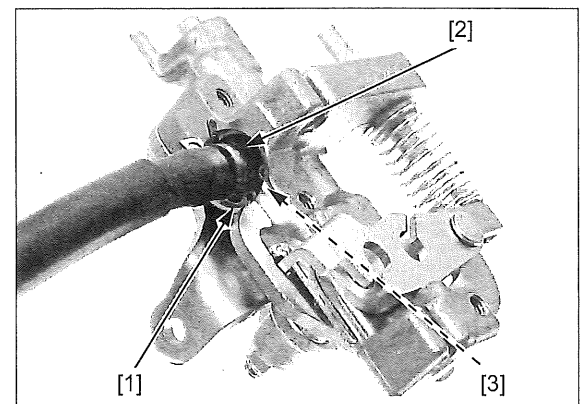



## HYDRAULIC BRAKE

Remove the delay spring [1].

- Do not loosen the lock nut [2].

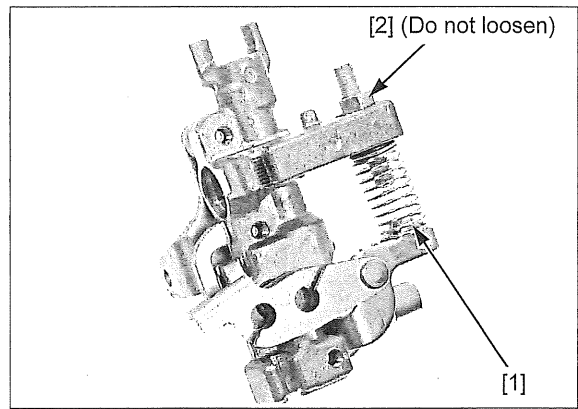

*The pivot nut and pivot screw have left-hand threads.*

Remove the pivot nut [1], washer [2], pivot screw [3], knocker arm [4] and equalizer [5].

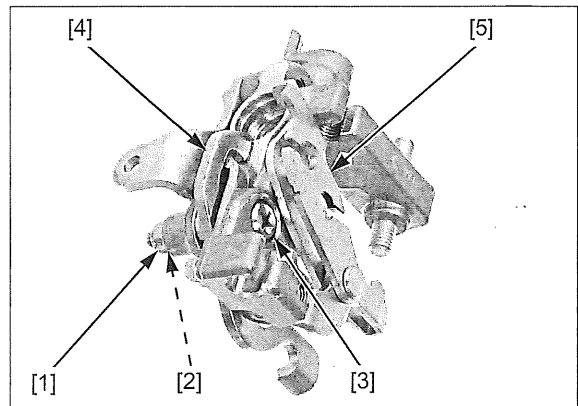

Remove the two bolts [1] and CBS master cylinder stay [2].

Remove the piston boot [3] from the CBS master cylinder and master piston.

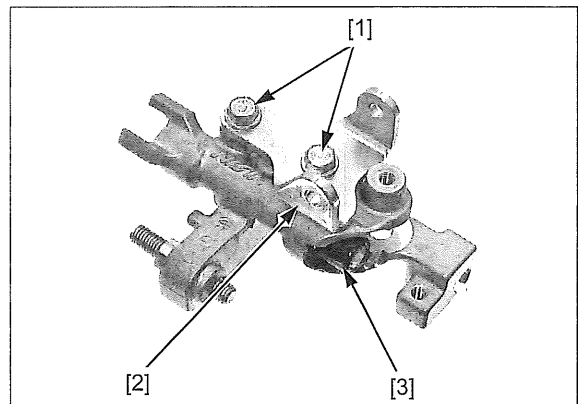

Remove the snap ring [1] using the special tool.

**TOOL:**

[2] Snap ring pliers

07914-SA50001

Remove the washer [3].

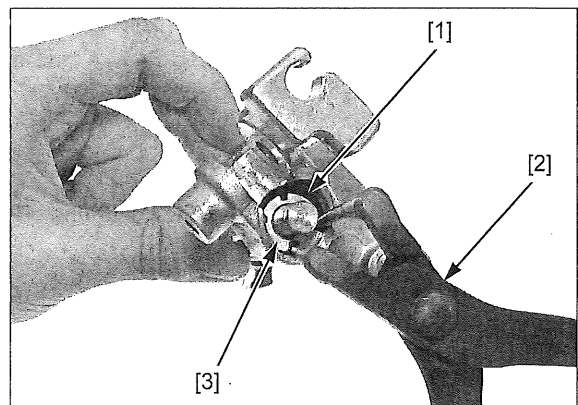



Remove the master piston [1] and spring [2].  
Clean the master cylinder, reservoir and master piston.

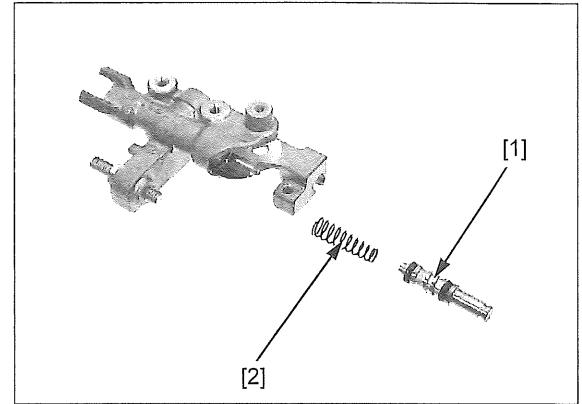

## INSPECTION

Check the piston cups for wear, deterioration or damage.  
Check the master cylinder inner surface and piston outer surface for scratches or damage.

Measure the master cylinder I.D.

**SERVICE LIMIT: 11.055 mm (0.4352 in)**

Measure the master piston O.D.

**SERVICE LIMIT: 10.945 mm (0.4309 in)**

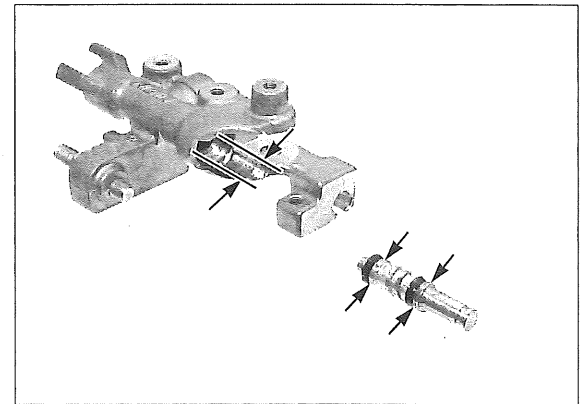

## ASSEMBLY

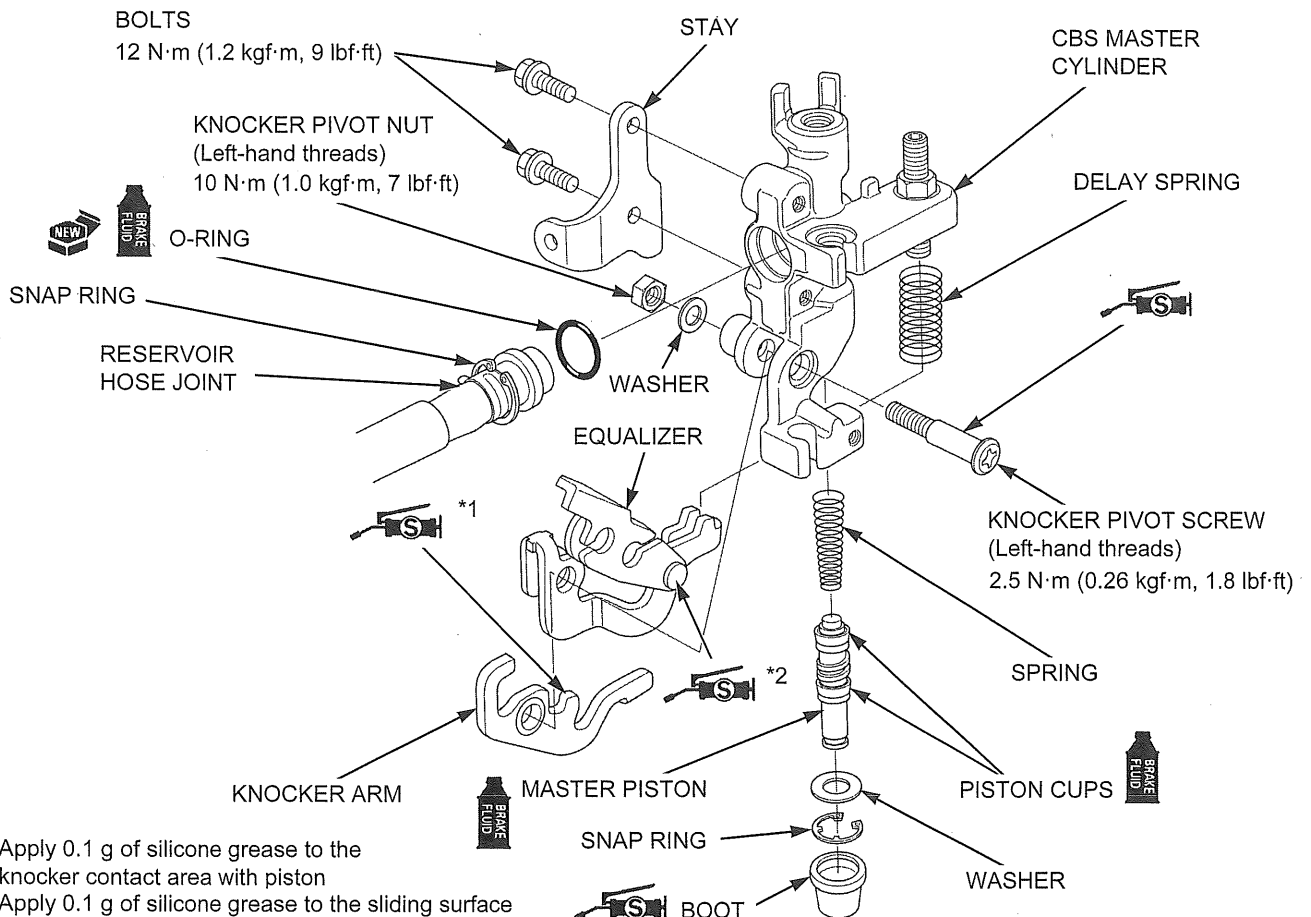

## HYDRAULIC BRAKE

- Keep the piston, cups, spring, snap ring and boot as a set; do not substitute individual parts.

Coat the master piston [1] and piston cups [2] with clean DOT 3 or DOT 4 brake fluid.

Install the spring [3] onto the master piston.

*Do not allow the piston cup lips to turn inside out.*

Install the spring and master piston into the master cylinder.

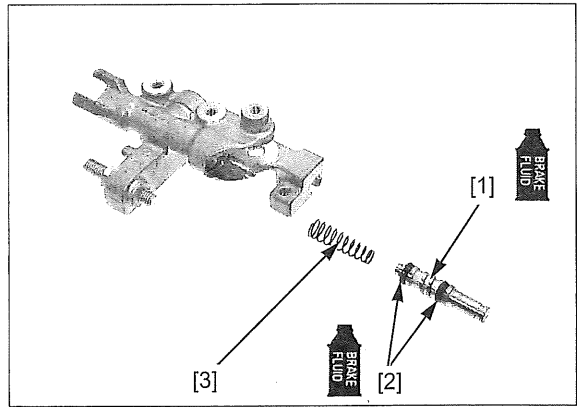

*Be sure that snap ring is firmly seated in the groove.*

Install the washer [1] and snap ring [2] into the groove in the master cylinder.

**TOOL:**

[3] Snap ring pliers

07914-SA50001

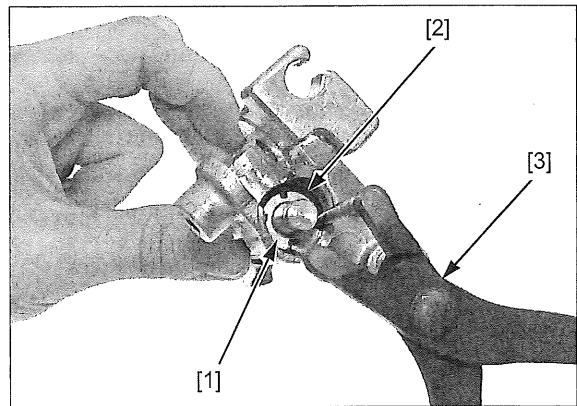

Install the CBS master cylinder stay [1].

Install the two bolts [2] and tighten them to the specified torque.

**TORQUE: 12 N·m (1.2 kgf·m, 9 lbf·ft)**

Apply silicone grease to the inside of the piston boot [3].

Install the piston boot into the master cylinder and groove of the piston.

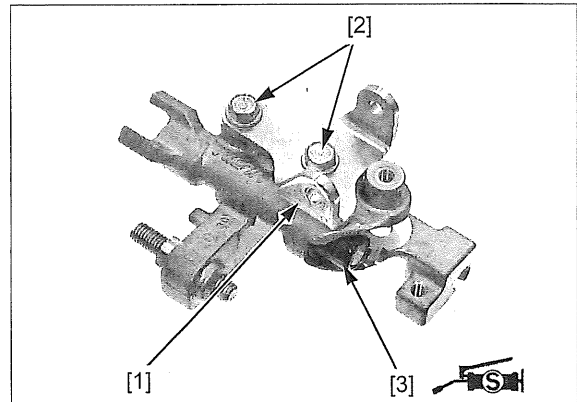

Apply 0.1 g of silicone grease to the equalizer sliding surface.

Set the equalizer [1] and knocker arm [2] onto the CBS master cylinder.

Apply 0.1 g of silicone grease to the contact surfaces of the knocker and piston tip.

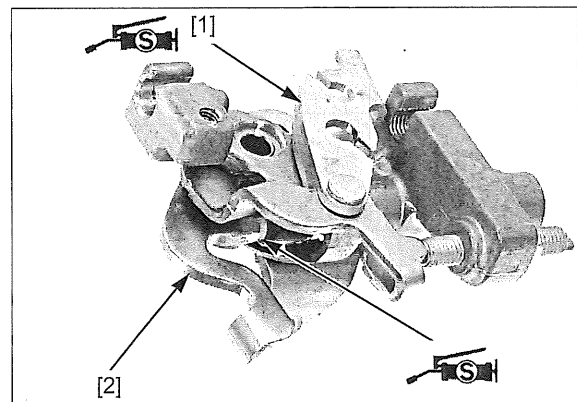

## HYDRAULIC BRAKE

Apply silicone grease to the knocker pivot screw [1] sliding area.

*The pivot screw has left-hand threads.* Install the pivot screw and tighten it to the specified torque.

**TORQUE: 2.5 N·m (0.26 kgf·m, 1.8 lbf·ft)**

*The pivot nut has left-hand threads.* Install the washer [2] and pivot nut [3], then tighten it to the specified torque while holding the pivot screw.

**TORQUE: 10 N·m (1.0 kgf·m, 7 lbf·ft)**

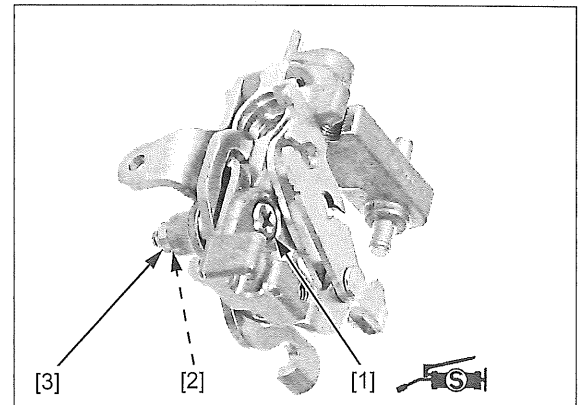

Install the delay spring [1].

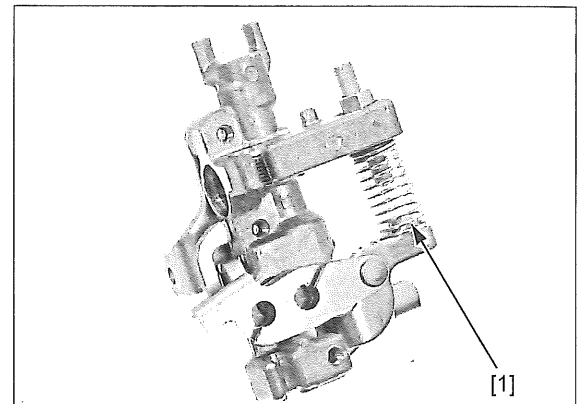

Coat a new O-ring [1] with clean DOT 3 or DOT 4 brake fluid.  
Install the O-ring onto the reservoir hose joint.

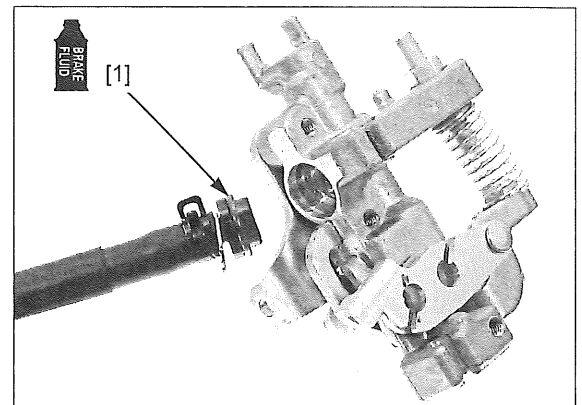

*Be sure that snap ring is firmly seated in the groove.* Install the reservoir hose joint [1] and snap ring [2] onto the CBS master cylinder.

**TOOL:**  
Snap ring pliers

**07914-SA50001**

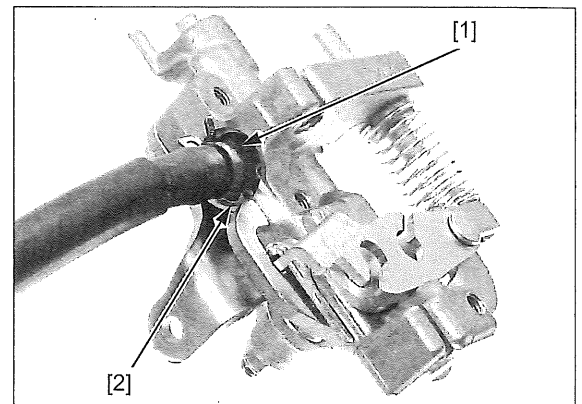

## HYDRAULIC BRAKE

### INSTALLATION

Set the CBS master cylinder [1] and temporarily install the left side CBS master cylinder mounting bolt [2].

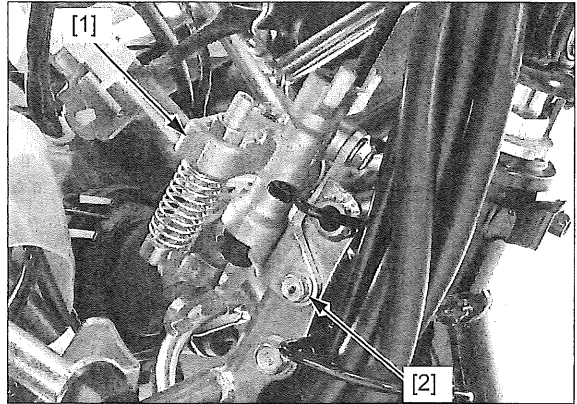

Install the 1st rear brake cable [1] into the equalizer [2] and temporarily tighten the adjuster [3].

Install the 2nd rear brake cable [4] into the equalizer and cable guide [5].

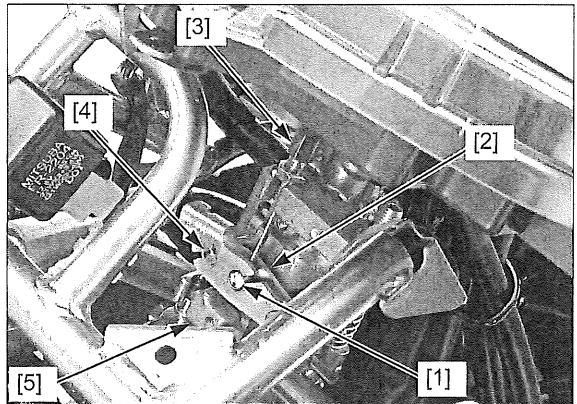

Set the brake lock stay [1] and temporarily install the right side CBS master cylinder mounting bolt [2].

Install the CBS master cylinder cover [3] by aligning the slot with the boss of the CBS master cylinder.

Set the collar [4] and temporarily install the brake lock stay mounting bolt [5].

Tighten the both side CBS master cylinder mounting bolts to the specified torque.

**TORQUE: 12 N·m (1.2 kgf·m, 9 lbf·ft)**

Tighten the brake lock stay mounting bolt to the specified torque.

**TORQUE: 12 N·m (1.2 kgf·m, 9 lbf·ft)**

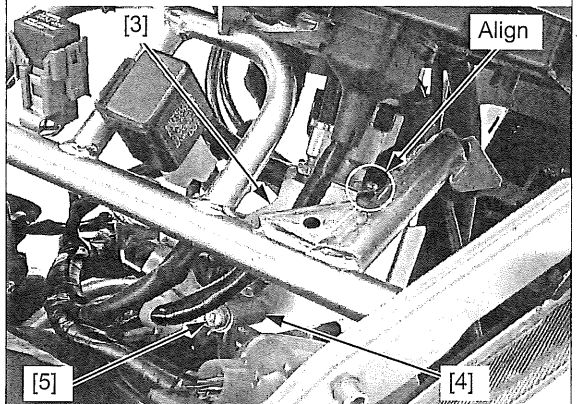
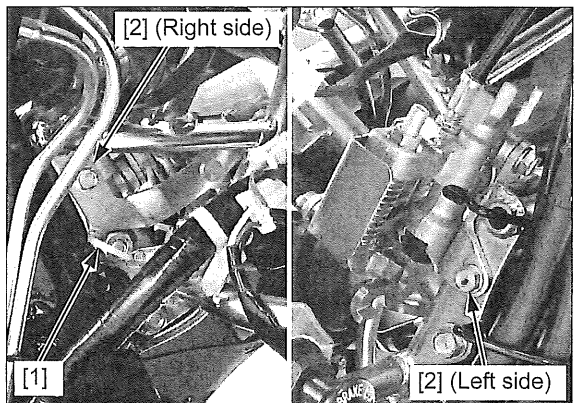

Connect the brake hose [1] with the oil bolt [2] and new sealing washers [3].

Set the brake hose joint against the stopper [4] of the CBS master cylinder then tighten the oil bolt to the specified torque.

**TORQUE: 34 N·m (3.5 kgf·m, 25 lbf·ft)**

Fill brake fluid and bleed air from the CBS brake line hydraulic system (page 19-8).

Adjust the CBS (page 3-19).

Install the following:

- Front meter panel (page 2-7)
- Inner cover (page 2-13)

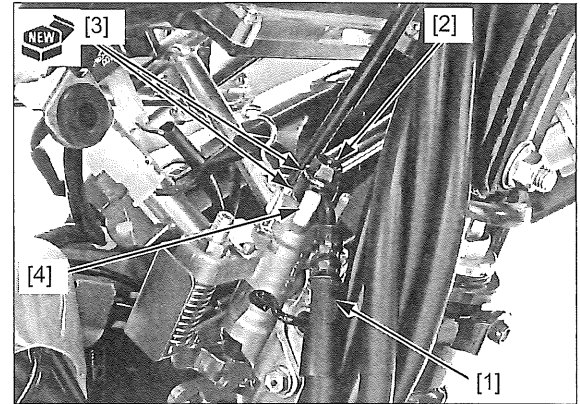

## BRAKE CALIPER

### REMOVAL

Drain the brake fluid from the following lines of the hydraulic systems:

- Front brake line (page 19-5)
- CBS brake line (page 19-6)

Remove the brake pads (page 19-10).

*When removing the oil bolts, cover the end of the hoses to prevent contamination.*

Disconnect the brake hoses [1] from the brake caliper by removing the oil bolts [2] and sealing washers [3].

Remove the front brake caliper mounting bolts and front brake caliper.

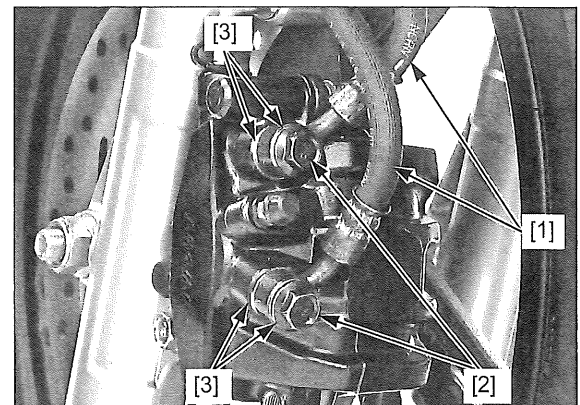

Remove the front brake caliper mounting bolts [1] and front brake caliper [2].

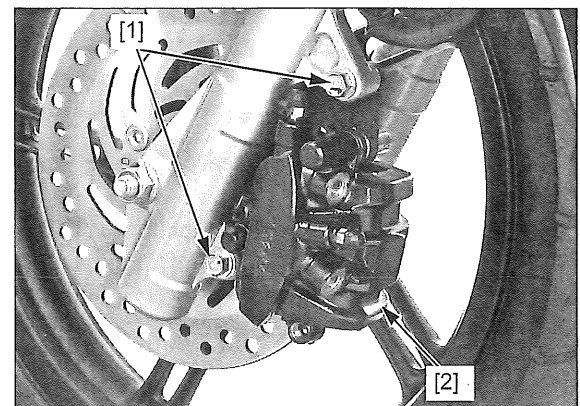

### DISASSEMBLY

Remove the caliper bracket [1], pin boots [2] and pad spring [3].

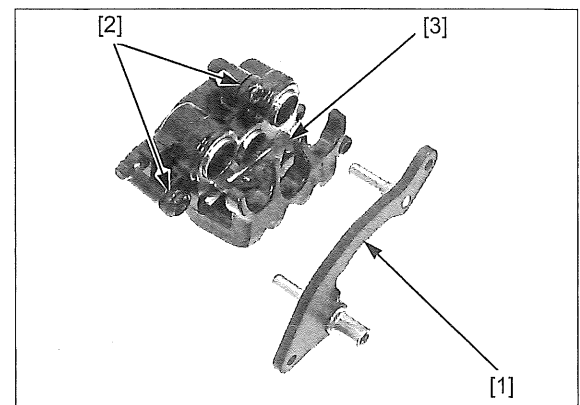

## HYDRAULIC BRAKE

Place a shop towel over the pistons.

*Do not use high pressure air or bring the nozzle too close to the inlet.*

Position the caliper body with the piston facing down and apply small squirts of air pressure to the fluid inlet to remove the three pistons.

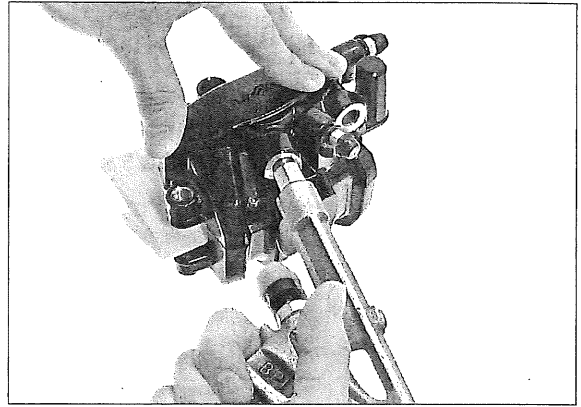

*Be careful not to damage the piston sliding surface.*

Push the dust seal [1] and piston seals [2] in and lift them out.

Clean the seal grooves, caliper cylinders and pistons.

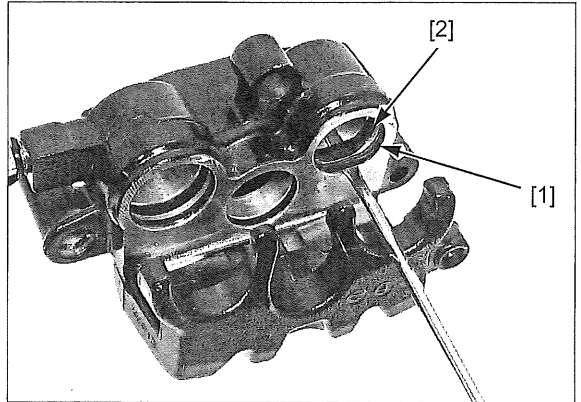

### INSPECTION

Check the caliper cylinder for scoring, scratches or damage.

Measure the caliper cylinder I.D.

#### SERVICE LIMIT:

**Upper:** 25.460 mm (1.0024 in)

**Center/lower:** 22.710 mm (0.8941 in)

Check the caliper piston for scoring, scratches or damage.

Measure the caliper piston O.D.

#### SERVICE LIMIT:

**Upper:** 25.31 mm (0.996 in)

**Center/lower:** 22.56 mm (0.8888 in)

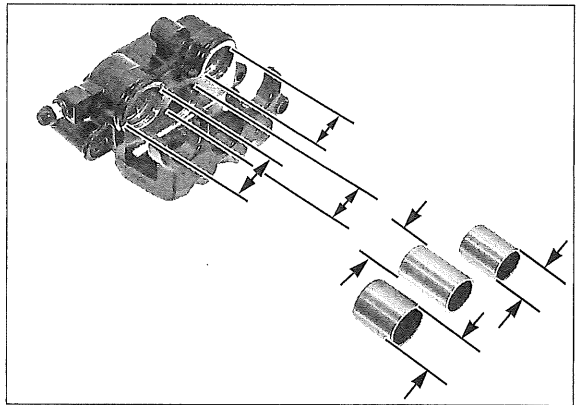

## ASSEMBLY

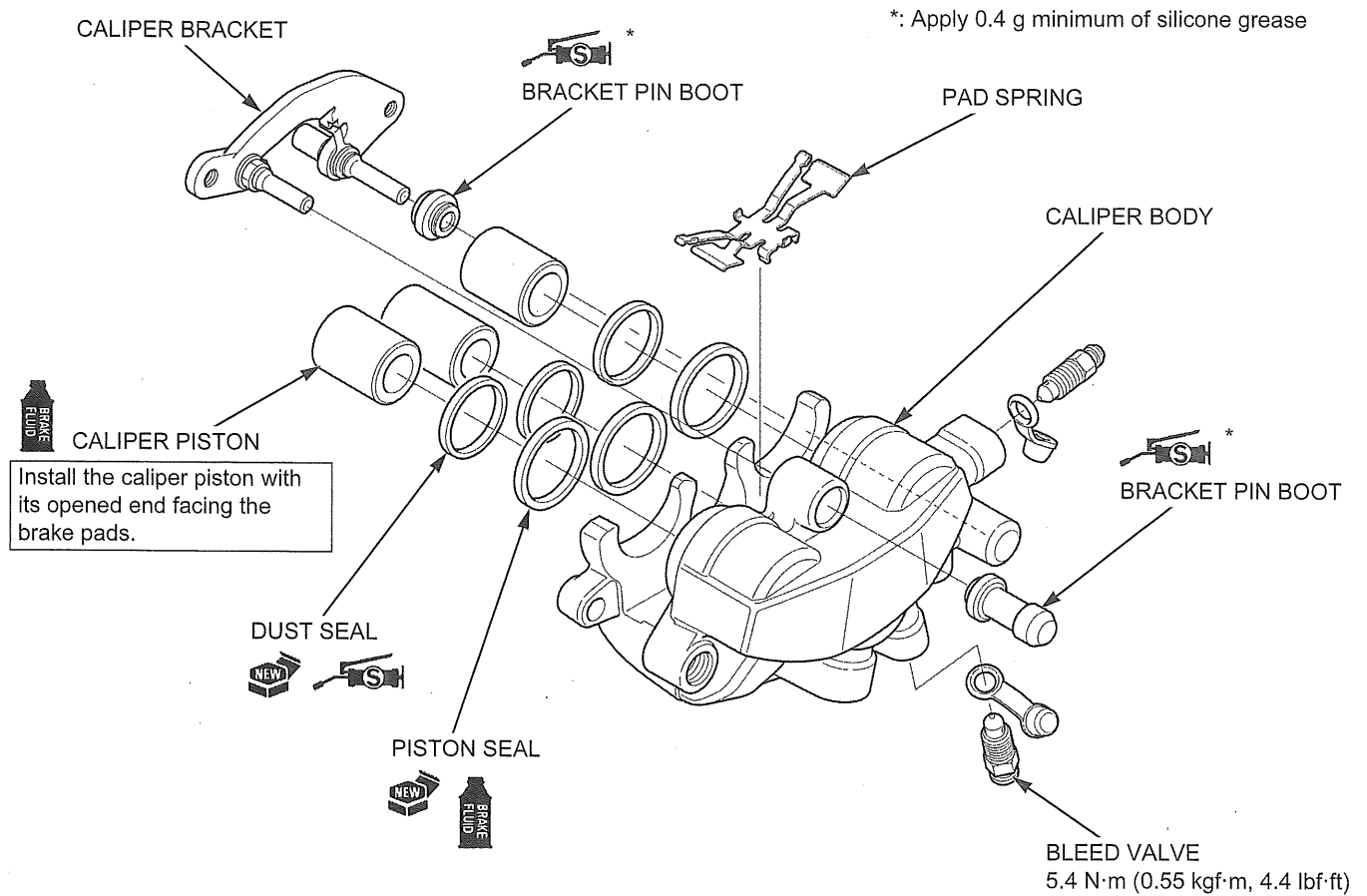

Coat new piston seals [1] with clean brake fluid and install them into the caliper.

Coat new dust seals [2] silicone grease and install them into the seal grooves in the caliper.

Coat the caliper piston [3] with clean brake fluid and install them into the caliper cylinders with the open side toward the pads.

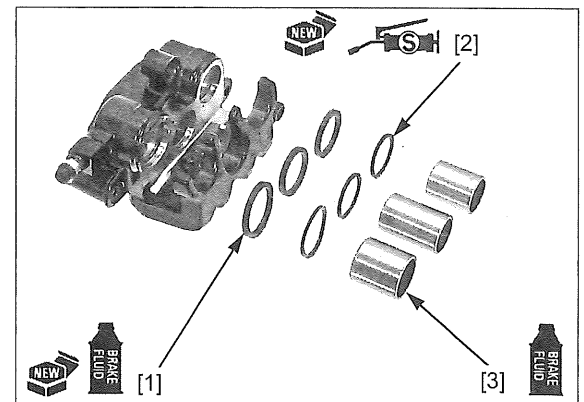

Check the pin boots [1] and replace them if they are hard, deteriorated or damaged.

Install the boot and pad spring [2] into the caliper [3].

Apply 0.4 g minimum of silicone grease to the inside of the boots and install the caliper bracket [4] over the caliper body.

Make sure the boot ribs are seated into the boot grooves in the slide pins properly.

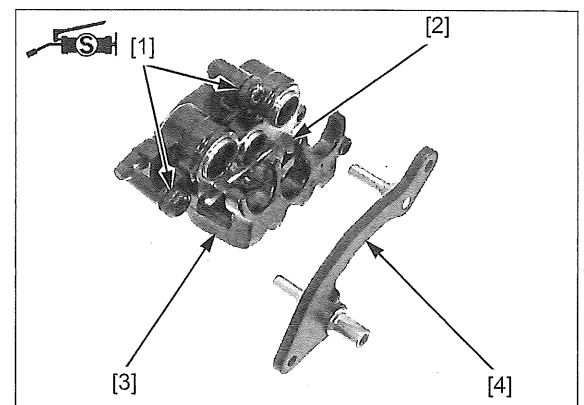

## HYDRAULIC BRAKE

### INSTALLATION

Install the front brake caliper [1] onto the left fork leg. Install the new front brake caliper mounting bolts [2] and tighten them to the specified torque.

**TORQUE: 30 N·m (3.1 kgf·m, 22 lbf·ft)**

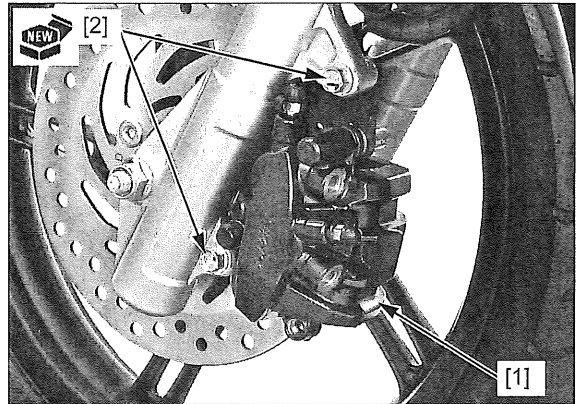

Connect the brake hoses [1] to the brake caliper with the oil bolts [2] and new sealing washers [3]. Set the hose eyelet joints onto the stoppers of the brake caliper and tighten the oil bolts to the specified torque.

**TORQUE: 34 N·m (3.5 kgf·m, 25 lbf·ft)**

Install the brake pads (page 19-10).

Fill and bleed the following lines of hydraulic systems:

- Front brake line (page 19-7)
- CBS brake line (page 19-8)

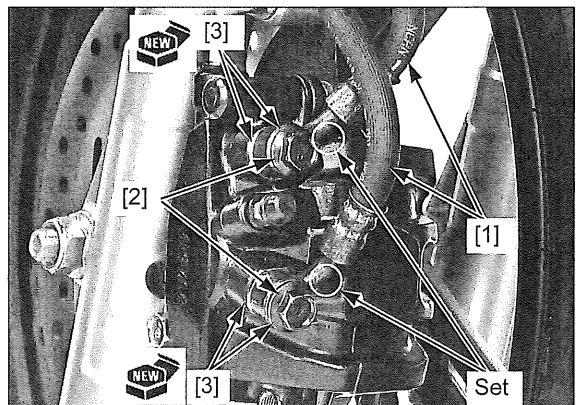



# 20. BATTERY/CHARGING SYSTEM

---

SYSTEM LOCATION .....	20-2	TROUBLESHOOTING .....	20-6
SYSTEM DIAGRAM .....	20-3	BATTERY.....	20-7
SERVICE INFORMATION.....	20-4	CHARGING SYSTEM .....	20-8

# BATTERY/CHARGING SYSTEM

## SYSTEM LOCATION

'13 model

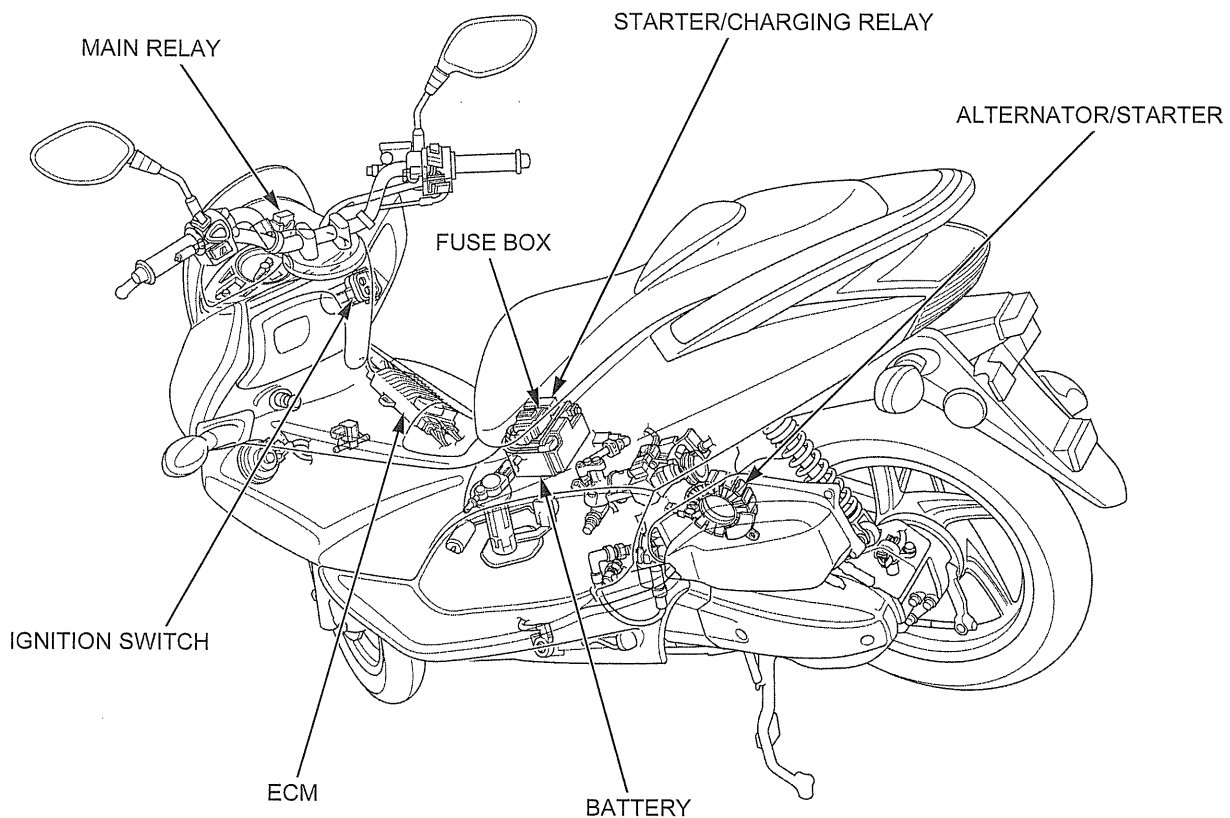

After '13 model:

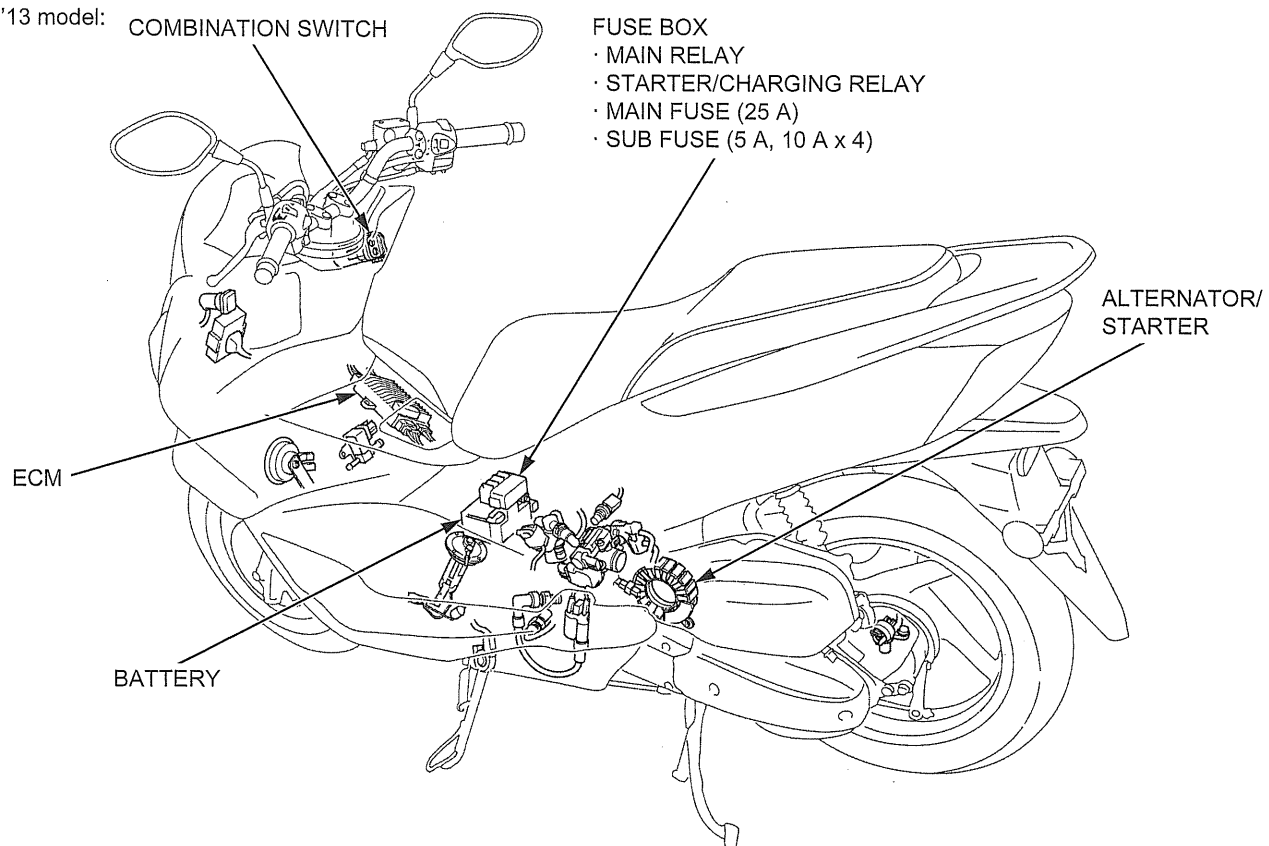

SYSTEM DIAGRAM

'13 model:

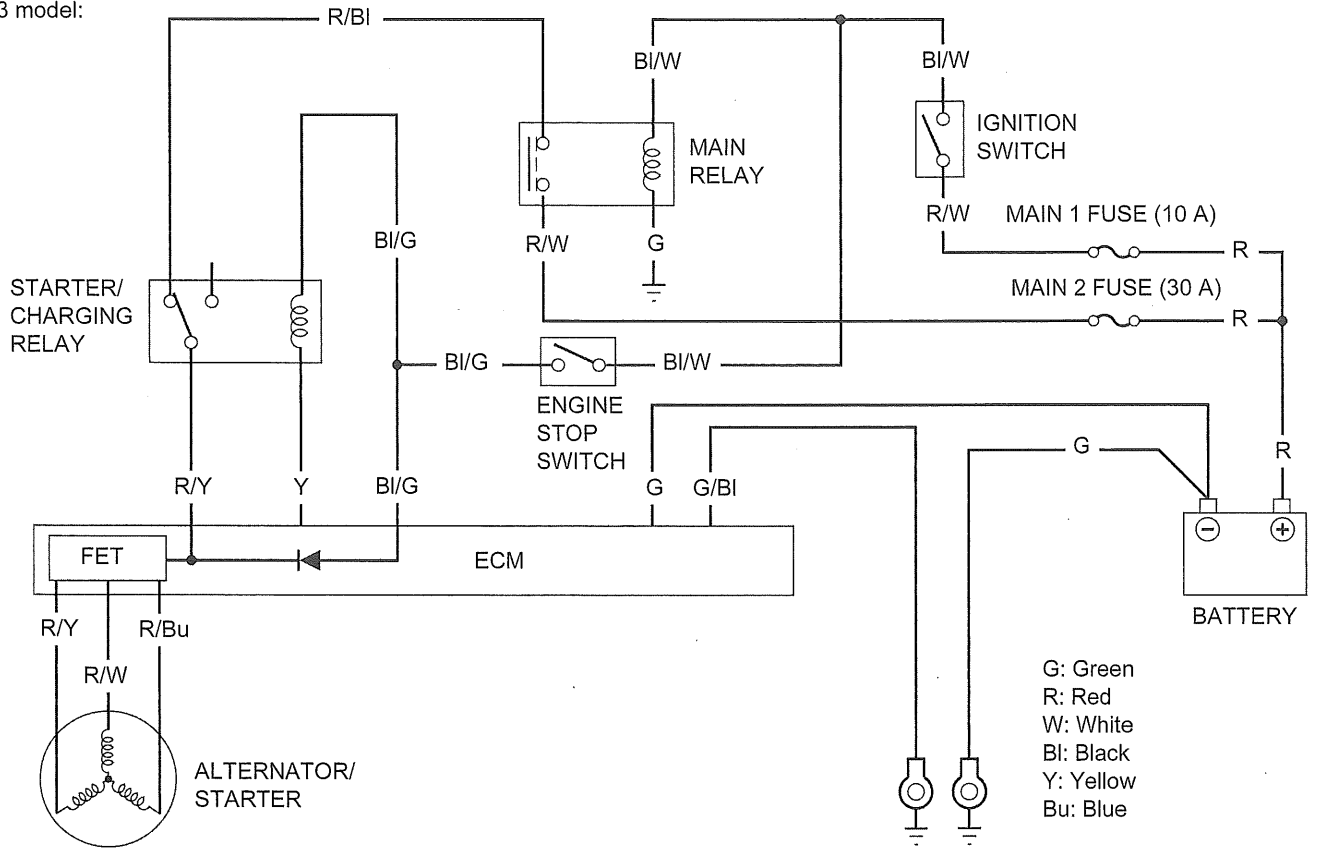

After '13 model:

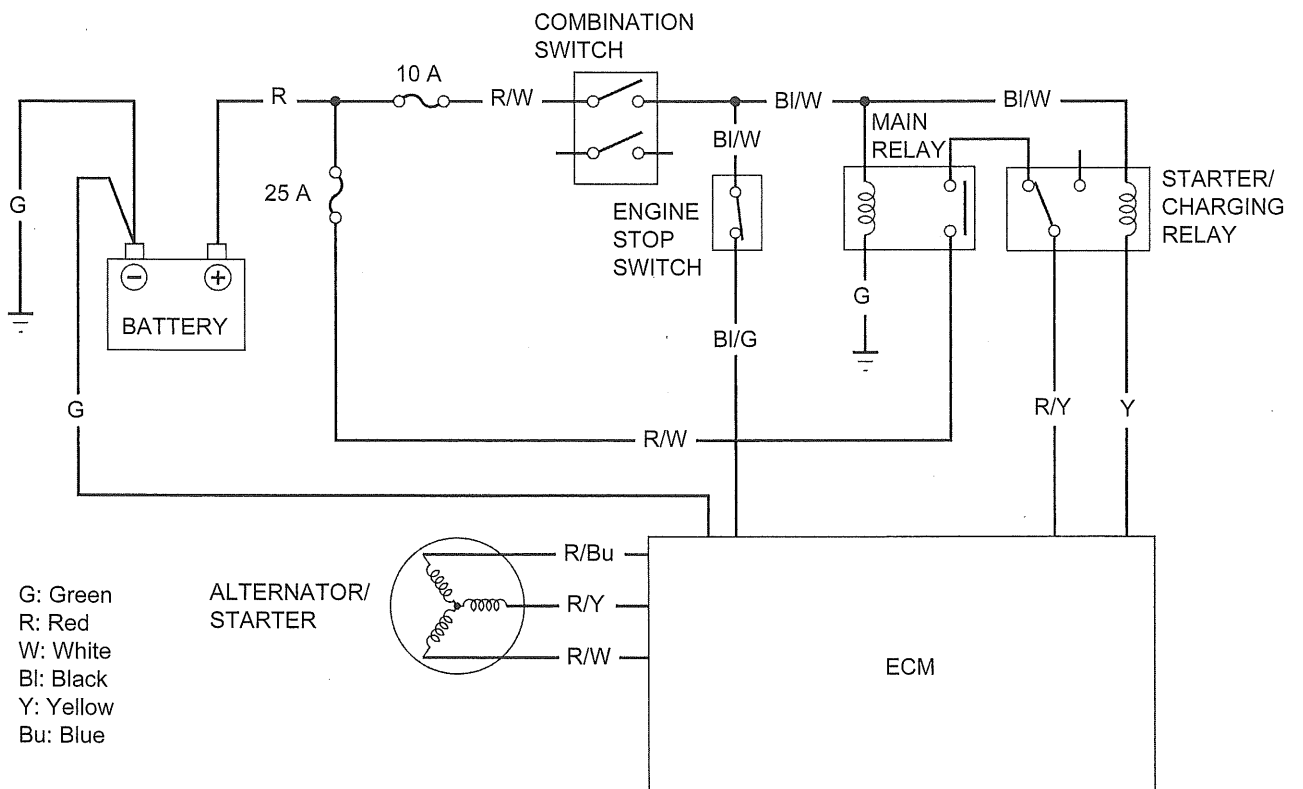

## BATTERY/CHARGING SYSTEM

# SERVICE INFORMATION

## GENERAL

### ⚠ WARNING

- The battery gives off explosive gases; keep sparks, flames and cigarettes away. Provide adequate ventilation when charging.
- The battery contains sulfuric acid (electrolyte). Contact with skin or eyes may cause severe burns. Wear protective clothing and a face shield.
  - If electrolyte gets on your skin, flush with water.
  - If electrolyte gets in your eyes, flush with water for at least 15 minutes and call a physician immediately.
- Electrolyte is poisonous.
  - If swallowed, drink large quantities of water or milk and call your local Poison Control Center or call a physician immediately.

### NOTICE

- *Always turn off the ignition switch before disconnecting any electrical component.*
- *Some electrical components may be damaged if terminals or connectors are connected or disconnected while the ignition switch is ON and current is present.*
- This model comes with a maintenance free (MF) battery. Remember the following about MF batteries.
  - Use only the electrolyte that comes with the battery.
  - Use all of the electrolyte.
  - Seal the battery properly.
  - Never open the seals after installation.
- For extended storage, remove the battery, give it a full charge, and store it in a cool, dry space. For maximum service life, charge the stored battery every two weeks.
- For a battery remaining in a stored scooter, disconnect the negative battery cable from the battery terminal.
- The maintenance free battery must be replaced when it reaches the end of its service life.
- The battery can be damaged if overcharged or undercharged, or if left to discharge for long period. These same conditions contribute to shortening the "life span" of the battery. Even under normal use, the performance of the battery deteriorates after 2-3 years.
- Battery voltage may recover after battery charging, but under heavy load, battery voltage will drop quickly and eventually die out. For this reason, the charging system is often suspected as the problem. Battery overcharge often results from problems in the battery itself, which may appear to be an overcharging symptom. If one of the battery cells is shorted and battery voltage does not increase, the regulator/rectifier supplies excess voltage to the battery. Under these conditions, the electrolyte level goes down quickly.
- Before troubleshooting the charging system, check for proper use and maintenance of the battery. Check if the battery is frequently under heavy load, such as having the headlight and taillight ON for long periods of time without riding the scooter.
- The battery will self-discharge when the scooter is not in use. For this reason, charge the battery every two weeks to prevent sulfation from occurring.
- When checking the charging system, always follow the steps in the troubleshooting flow chart (page 20-6).
- For battery charging, do not exceed the charging current and time specified on the battery. Use of excessive current or charging time may damage the battery.
- The scooter has alternator/starter. The alternator/starter has alternator and starter functions.
- The regulator/rectifier is built into the ECM.
- The flywheel, alternator and CKP sensor services can be done with the engine installed in the frame (page 14-3).

### BATTERY CHARGING

- Turn the power ON/OFF at the charger, not at the battery terminal.
- For battery charging, do not exceed the charging current and time specified on the battery. Using excessive current or extending the charging time may damage the battery.
- Quick charging should only be done in an emergency; slow charging is preferred.

### BATTERY TESTING

Refer to the instruction of the Operation Manual for the recommended battery tester for details about battery testing. The recommended battery tester puts a "load" on the battery so that the actual battery condition of the load can be measured.

**Recommended battery tester:**     **Micro 404XL (U.S.A. only)**

SPECIFICATIONS

ITEM		SPECIFICATIONS	
Battery	Type	'13 model	YTZ7S
		After '13 model	GTZ8V
	Capacity	'13 model	12 V – 6 Ah (10HR)
		After '13 model	12 V – 7 Ah (10HR)
	Current leakage	'13 model	0.1 mA max.
		After '13 model	0.4 mA max.
	Voltage	Fully charged	13.0 – 13.2 V
		Needs charging	Below 12.4 V
Charging current	Normal	'13 model	0.6 A/5 – 10 h
		After '13 model	0.5 A/5 – 10 h
	Quick	'13 model	3 A/1 h
		After '13 model	2.5 A/1 h
Alternator	Capacity	0.343 kW/5,000 rpm	

TOOLS

Motorcycle battery analyzer  
Micro 404XL

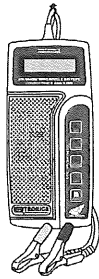

Christie battery charger  
MC1012/2T or OptiMate 4 PRO S  
(U.S.A. only)

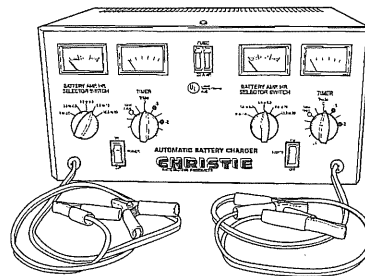

## TROUBLESHOOTING

### BATTERY IS DAMAGED OR WEAK

#### 1. Battery Test

Check the battery condition (page 20-8).

**Is the battery in good condition?**

**YES** – GO TO STEP 2.

**NO** – Faulty battery

#### 2. Current Leakage Test

Install the battery (page 20-7).

Check the battery current leakage (page 20-8).

**Is the current leakage below 0.1 mA?**

**YES** – GO TO STEP 4.

**NO** – GO TO STEP 3.

#### 3. Current Leakage Test Without Regulator/rectifier built in ECM

Disconnect the following connectors:

- ECM 3P (Black) connector (page 4-49).
- ECM 5P connector (page 4-49).

Recheck the battery current leakage.

**Is the current leakage below 0.1 mA?**

**YES** – Faulty regulator/rectifier in ECM.

**NO** – • Shorted wire harness  
• Faulty ignition switch

#### 4. Charging Voltage Inspection

Measure and record the battery voltage using a digital multimeter (page 20-8).

Start the engine.

Measure the charging voltage (page 20-9).

Compare the measurements to result of the following calculation.

**STANDARD: Measured BV < Measured CV < 15.5 V**

- **BV = Battery Voltage**
- **CV = Charging Voltage**

**Is the measured charging voltage within the standard voltage?**

**YES** – Faulty battery.

**NO** – GO TO STEP 5.

#### 5. Starter/charging Relay Operation Inspection

Check the starter/charging relay operation (page 20-10).

**Is the operation normal?**

**YES** – GO TO STEP 6.

**NO** – Faulty starter/charging relay

#### 6. Starter/charging Relay Line Inspection

Install the starter/charging relay (page 6-8).

Disconnect the ECM 5P connector (page 4-49).

Turn the ignition switch ON and engine stop switch "O".

Measure the voltage at the ECM connector (page 20-9).

**STANDARD: Battery voltage**

**Does battery voltage exist?**

**YES** – Replace the ECM with a new one and recheck.

**NO** – • Loose or poor contacts of related terminal  
• Open circuit in the Red/black wire between the main relay and starter/charging relay  
• Open circuit in the Red/yellow wire between the starter/charging relay and ECM

# BATTERY

## REMOVAL/INSTALLATION

**NOTE:**

- Always turn the ignition switch OFF before removing the battery.

'13 model: Unlock and open the seat.

Remove the trim clip [1].

Remove the battery maintenance lid [2] from the luggage box.

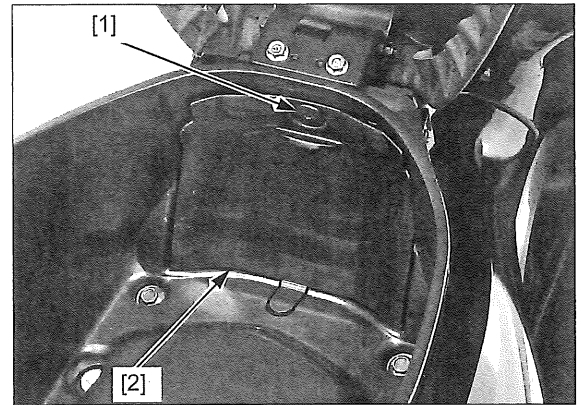

After '13 model: Unlock and open the seat.

Press the tabs [1] and remove the battery maintenance lid [2].

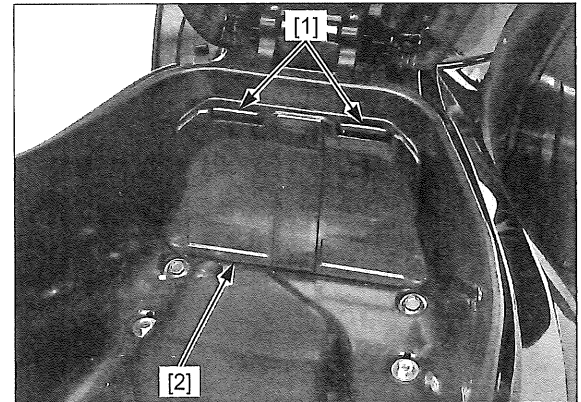

Release the battery band [1].

Remove the bolt [2] and disconnect the negative (-) cable [3].

Remove the bolt [4] and disconnect the positive (+) cable [5].

Remove the battery [6].

*Connect the positive terminal first and then the negative terminal.*

Install the battery in the reverse order of removal.

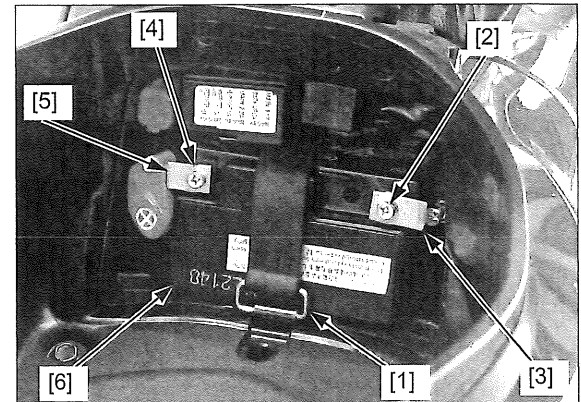

## BATTERY/CHARGING SYSTEM

### VOLTAGE INSPECTION

Remove the battery maintenance lid (page 20-7).

Measure the battery voltage using a commercially available digital multimeter.

**VOLTAGE (20 °C/68 °F):**

**Fully charged: 13.0 – 13.2 V**

**Under charged: Below 12.4 V**

**NOTE:**

- Voltage fluctuates just after charging; wait at least 30 minutes before measuring.

Install the battery maintenance lid (page 20-7).

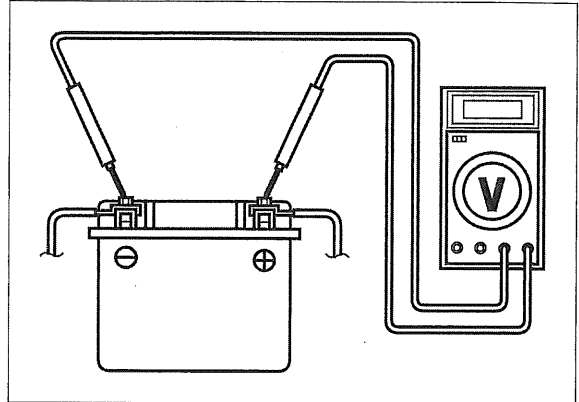

### BATTERY TESTING

Refer to the instructions that are appropriate to the battery testing equipment available to you.

**TOOL:**

**Recommended battery tester: Micro 404XL  
(U.S.A. only)**

### BATTERY CHARGING

Remove the battery (page 20-7).

Refer to the instructions that are appropriate to the battery charging equipment available to you.

**TOOL:**

**Christie battery MC1012/2T or OptiMate 4 PRO S  
charger (U.S.A. only)**

## CHARGING SYSTEM

### CURRENT LEAKAGE TEST

Remove the battery maintenance lid (page 20-7).

Turn the ignition switch to OFF and disconnect the negative (-) cable [1] from the battery.

Connect the ammeter (+) probe [2] to the negative (-) cable and ammeter (-) probe [3] to the battery (-) terminal.

With the ignition switch turned to OFF, check for current leakage.

**NOTE:**

- When measuring current using a tester, set it to a high range, and then bring the range down to an appropriate level. Current flow higher than the range selected may blow the fuse in the tester.
- While measuring current, do not turn the ignition switch ON and engine stop switch "O". A sudden surge of current may blow the fuse in the tester.

**SPECIFIED CURRENT LEAKAGE:**

**'13 model: 0.1 mA max.**

**After '13 model: 0.4 mA max.**

If current leakage exceeds the specified value, a shorted circuit is likely.

Locate the short by disconnecting connections one by one and measuring the current.

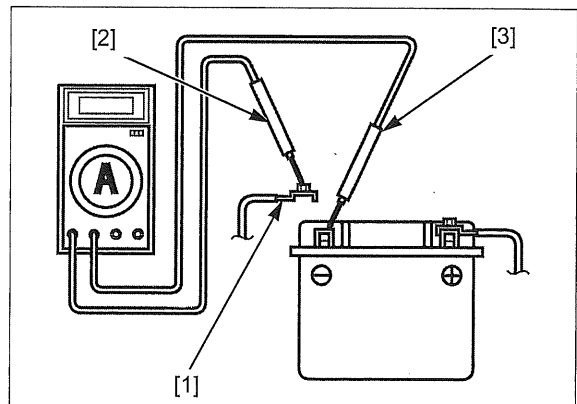



**CHARGING VOLTAGE INSPECTION**

**NOTE:**

- Make sure the battery is in good condition before performing this test.
- Do not disconnect the battery or any cable in the charging system without first switching the ignition switch to OFF. Failure to follow this precaution can damage the tester or electrical components.

Warm up the engine to normal operating temperature. Stop the engine.

*To prevent a short, make absolutely certain which are the positive and negative terminals or cables.*

Remove the battery maintenance lid (page 20-7) and connect the multimeter as shown.

Connect a tachometer.

With the headlight on high beam, restart the engine. Measure the voltage on the multimeter when the engine runs at 5,000 rpm.

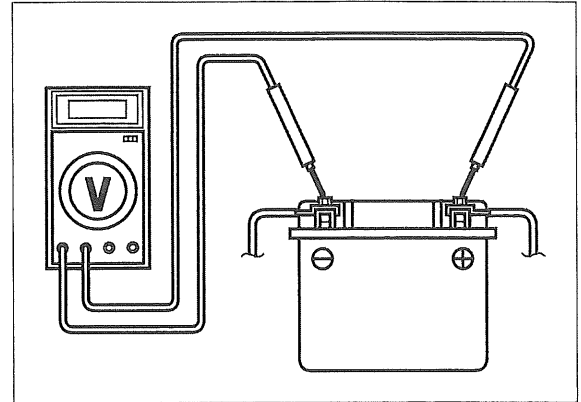

**STANDARD:**

**Measured BV < Measured CV < 15.5 V**

- **BV = Battery Voltage (page 20-8)**
- **CV = Charging Voltage**

**CHARGING LINE INSPECTION**

Disconnect the ECM 5P connector (page 4-49).

Turn the ignition switch ON and engine stop switch "O". Measure the voltage between the ECM 5P connector [1] of the wire harness side and ground.

**CONNECTION: Red/yellow (+) – ground (-)**

**STANDARD: Battery voltage**

If there is battery voltage, charging line is normal. If there is no voltage, inspect the following:

- Loose or poor contacts of related terminal
- Open circuit in the Red/black wire between the main relay and starter/charging relay
- Open circuit in the Red/yellow wire between the starter/charging relay and ECM

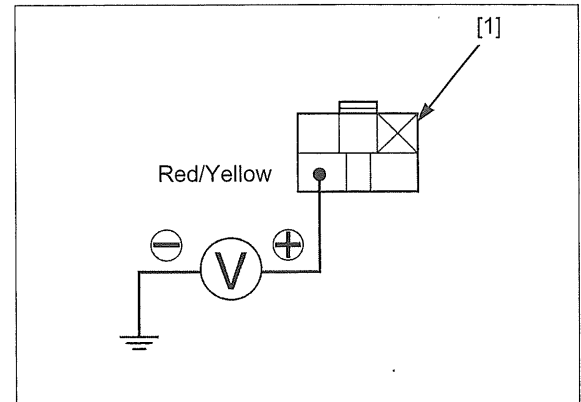

## BATTERY/CHARGING SYSTEM

### STARTER/CHARGING RELAY INSPECTION

Remove the starter/charging relay (page 6-8).

Connect an ohmmeter to the following relay connector terminals.

#### CONNECTION: A – B

Connect a 12 V battery to the following relay connector terminals.

#### CONNECTION: D – E

There should be no continuity when the battery is connected and there should be continuity only when the battery is disconnected.

If the above inspection is abnormal, replace the starter/charging relay.

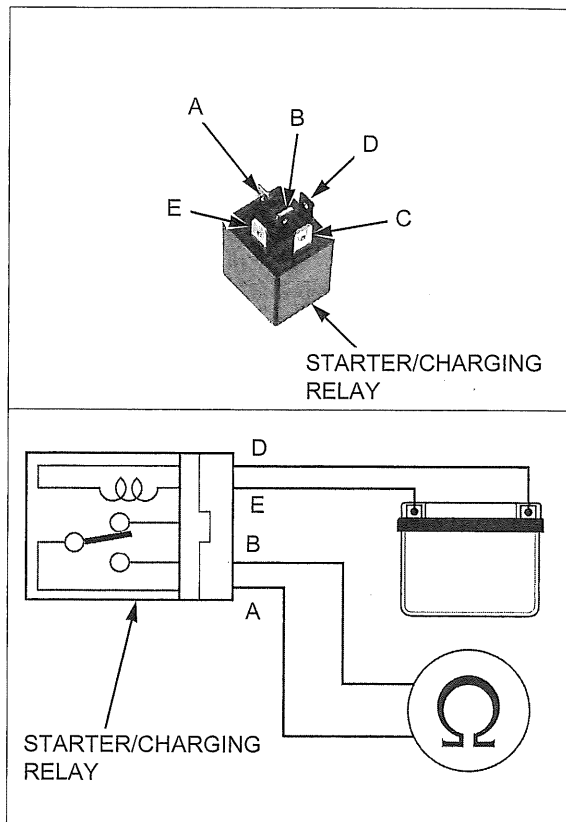

# 21. LIGHTS/METERS/SWITCHES

---

ELECTRICAL SYSTEM LOCATION .....	21-2	VS SENSOR .....	21-16
SERVICE INFORMATION .....	21-4	COOLANT TEMPERATURE INDICATOR .....	21-18
HEADLIGHT ('13 MODEL).....	21-6	FUEL METER/FUEL LEVEL SENSOR ....	21-19
COMBINATION LIGHT (AFTER '13 MODEL) .....	21-7	IGNITION SWITCH .....	21-21
TURN SIGNAL LIGHT ('13 MODEL).....	21-7	HANDLEBAR SWITCHES .....	21-24
TAIL/BRAKE LIGHT ('13 MODEL) .....	21-8	BRAKE LIGHT SWITCH.....	21-25
LICENSE LIGHT .....	21-9	HORN .....	21-25
SPEEDOMETER ('13 MODEL) .....	21-10	ACCESSORY SOCKET (AFTER '13 MODEL) .....	21-26
COMBINATION METER (AFTER '13 MODEL) .....	21-12	MAIN RELAY .....	21-27
FUEL GAUGE (AFTER '13 MODEL).....	21-15	TURN SIGNAL LIGHT RELAY ( '13 MODEL) .....	21-28
AVERAGE FUEL MILEAGE (AFTER '13 MODEL) .....	21-15	LED CONTROL UNIT (AFTER '13 MODEL) .....	21-28

# LIGHTS/METERS/SWITCHES

## ELECTRICAL SYSTEM LOCATION

'13 model:

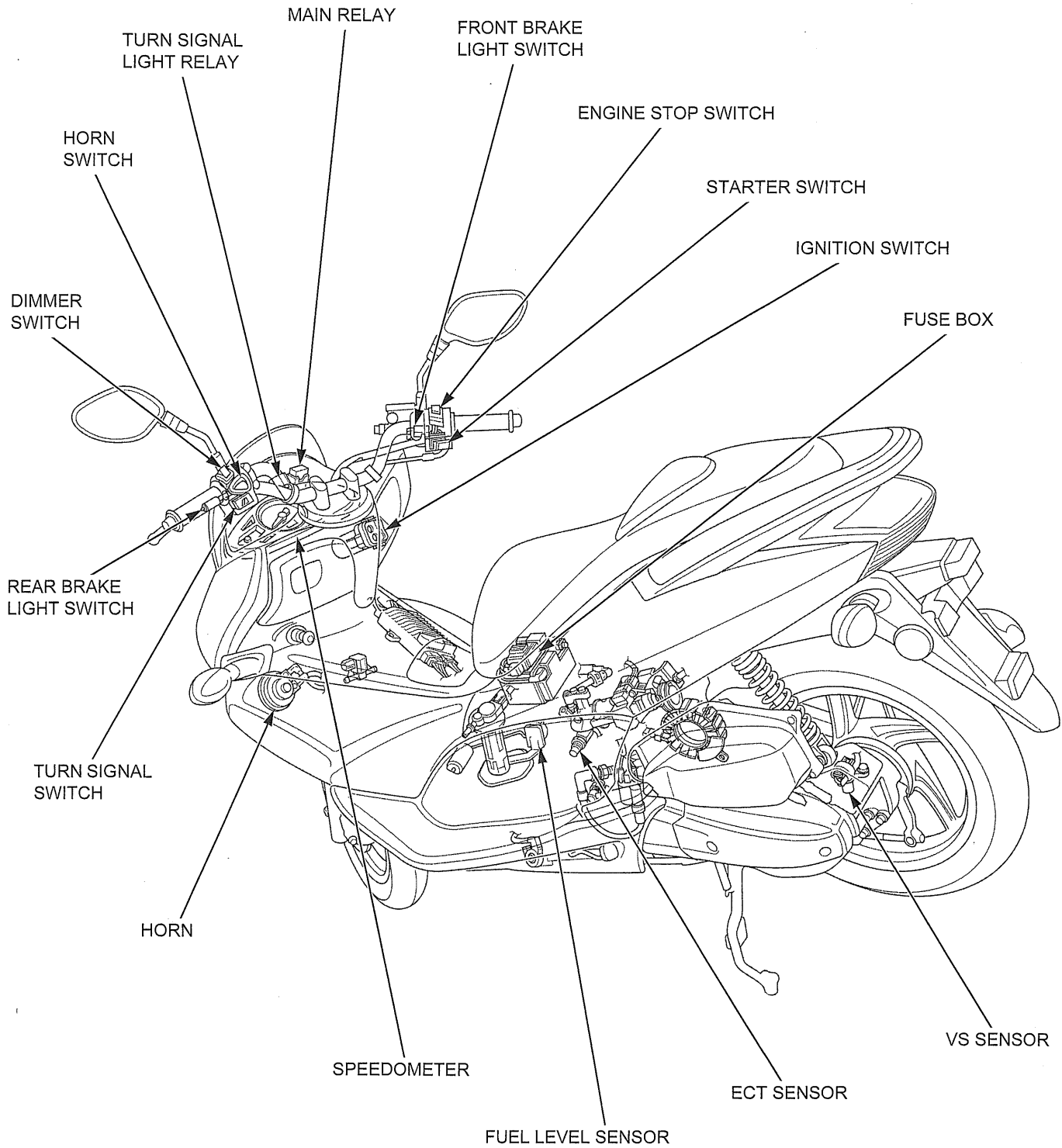

After '13 model:

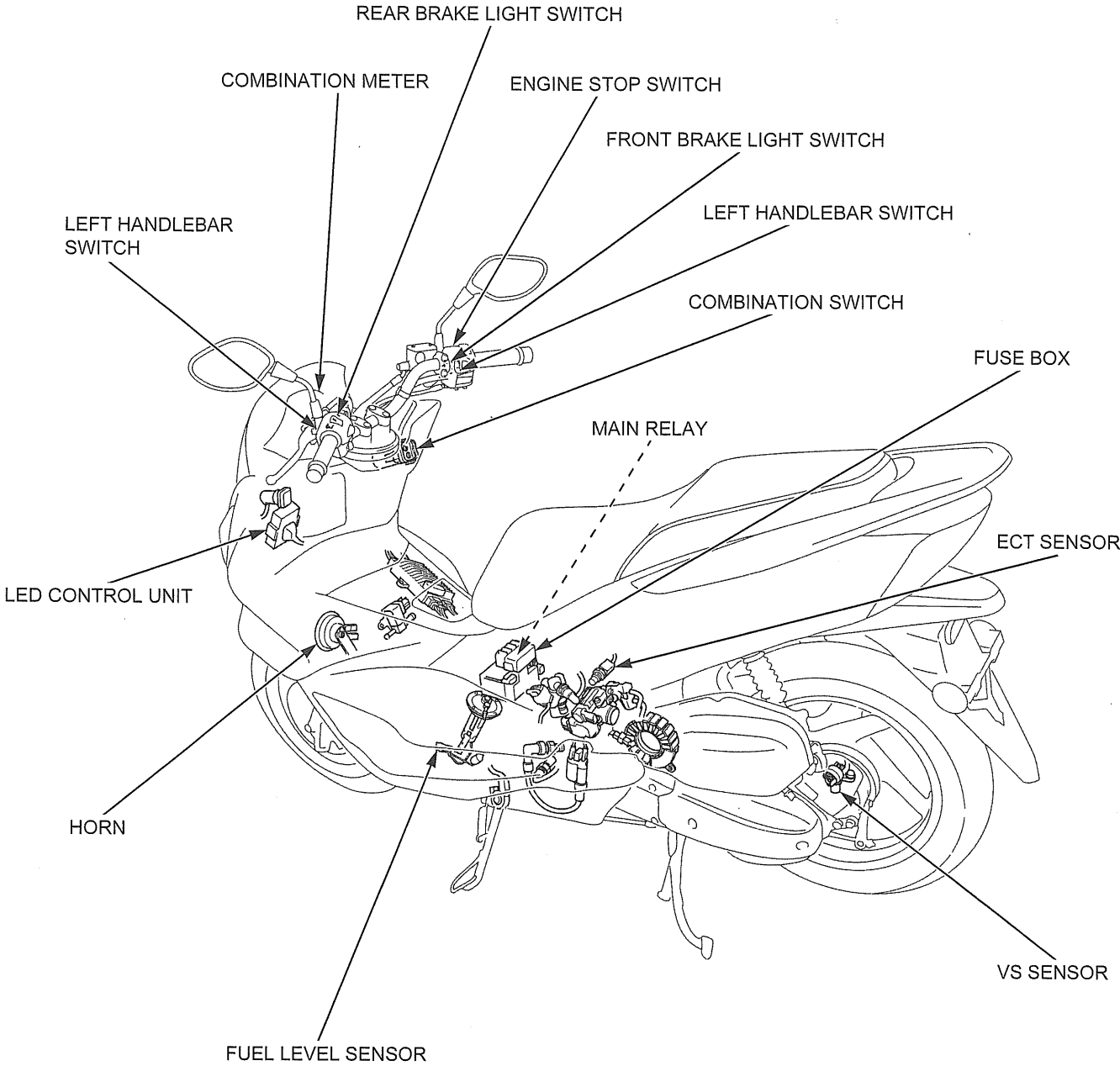

## LIGHTS/METERS/SWITCHES

# SERVICE INFORMATION

## GENERAL

### NOTICE

- Note the following when replacing the halogen headlight bulb.
  - Wear clean gloves while replacing the bulb. Do not put fingerprints on the headlight bulb, as they may create hot spots on the bulb and cause it to fail.
  - If you touch the bulb with your bare hands, clean it with a cloth moistened with alcohol to prevent its early failure.
- Check the battery condition before performing any inspection that requires proper battery voltage.
- A halogen headlight bulb becomes very hot while the headlight is on, and remains hot for a while after it is turned off. Be sure to let it cool down before servicing.
- A continuity test can be made with the switches installed on the scooter.
- The following color codes are used throughout this section.

Bu: Blue  
Bl: Black

G: Green  
Gr: Gray

Lg: Light Green  
O: Orange

W: White  
Y: Yellow

Br: Brown  
Lb: Light Blue

R: Red  
P: Pink

## SPECIFICATIONS

ITEM		SPECIFICATIONS	
Bulbs	Headlight	'13 model	12 V – 35/30 W x 2
		After '13 model	LED
	Position light (After '13 model)		LED
	Tail/brake light	'13 model	12 V – 5 W/21W
		After '13 model	LED
	License light	'13 model	12 V – 5 W
		After '13 model	LED
	Front turn signal light	'13 model	12 V – 21 W x 2
		After '13 model	LED
	Rear turn signal light	'13 model	12 V – 21 W x 2
		After '13 model	LED
	Instrument light		LED
	PGM-FI malfunction indicator lamp (MIL)		LED
	High beam indicator		LED
Turn signal indicator		LED	
Coolant temperature indicator		LED	
Fuse	Main fuse 1 ('13 model)		10 A
	Main fuse 2 ('13 model)		30 A
	Main fuse (After '13 model)		25 A
	Sub fuse	'13 model	10 A x 3, 15 A x 1
		After '13 model	5 A, 10 A x 4

## TORQUE VALUES

ITEM	Q'TY	THREAD DIA. (mm)	TORQUE N·m (kgf·m, lbf·ft)	REMARKS
Front/rear turn signal light lens screw ('13 model)	4	4	0.9 (0.09, 0.7)	
Rear turn signal light lens screw ('13 model)	2	6	8.8 (0.9, 6.5)	U-nut
License light lens screw ('13 model)	2	4	1 (0.1, 0.7)	
License light unit mounting nut ('13 model)	2	5	4.3 (0.44, 3.2)	U-nut
License light unit mounting screw (After '13 model)	2	4	1.2 (0.12, 0.9)	
Combination meter mounting screw (After '13 model)	4	5	1.2 (0.12, 0.9)	
Combination meter screw (After '13 model)	7	4	1.2 (0.12, 0.9)	
Speedometer mounting screw ('13 model)	4	5	1.1 (0.11, 0.8)	
Speedometer screw ('13 model)	8	3	0.54 (0.06, 0.4)	
VS sensor protector socket bolt	2	6	10 (1.0, 7)	Apply locking agent to the threads.
Fuel lid/seat opener lower cover screw	1	4	1.1 (0.11, 0.8)	
Key shutter socket bolt	1	5	5.1 (0.52, 3.8)	
Ignition switch mounting screw	2	6	9 (0.9, 6.6)	

## TOOL

Test probe, 2 pack  
07ZAJ-RDJA110

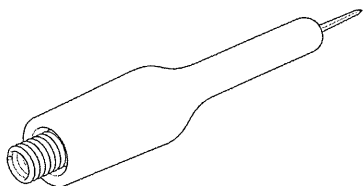

## HEADLIGHT ('13 MODEL)

### BULB REMOVAL/INSTALLATION

Pull the dust cover [1].  
 Turn the headlight bulb [2] counterclockwise and remove it from the headlight case.  
 Disconnect the bulb from the 3P connector [3].

#### NOTICE

*Avoid touching the halogen headlight bulb. Finger prints can create hot spots that cause a bulb to break.*

Installation is in the reverse order of removal.

- Install the dust cover with its "TOP" mark [4] facing up.

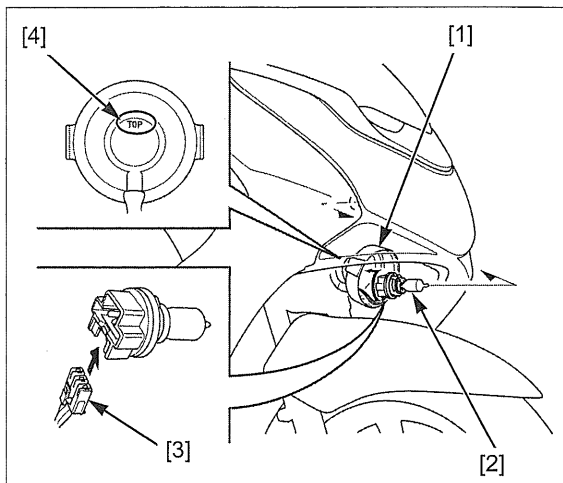

### HEADLIGHT INSPECTION

Disconnect the ECM 5P connector (page 4-49).

Turn the ignition switch ON and engine stop switch "O".  
 Measure the voltage between the ECM 5P connector [1] of the wire harness side and ground.

**CONNECTION:** Green/orange (+) – ground (-)  
**STANDARD:** Battery voltage

If there is battery voltage, the headlight line is normal.  
 If there is no voltage, inspect the following:

- Blown HEADLIGHT fuse (10 A)
- Loose or poor contacts of related terminal
- Open circuit in the Green/orange wire between the headlight and ECM
- Open circuit in the Blue or White wire between the headlight and dimmer switch
- Open circuit in the Black/red wire between the dimmer switch and fuse box
- Faulty dimmer switch (page 21-24)

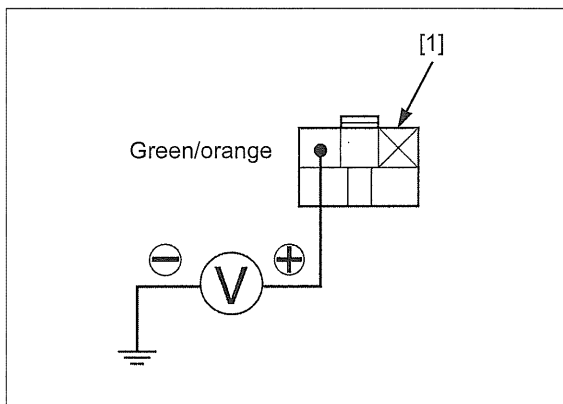

### REMOVAL/INSTALLATION

Remove the front cover (page 2-15).

Disconnect the headlight 6P connector [1].  
 Remove the bolts [2] from the headlight unit [3].  
 Remove headlight unit while releasing the bosses [4] from the frame grommets.

Installation is in the reverse order of removal.

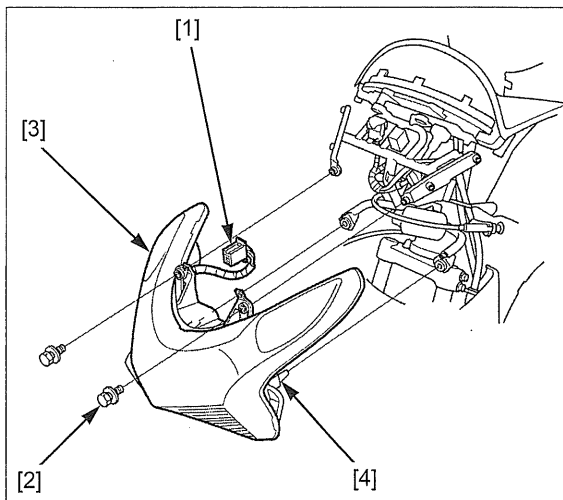



## COMBINATION LIGHT (AFTER '13 MODEL)

### REMOVAL/INSTALLATION

Remove the front cover (page 2-15).

Disconnect the front combination light 8P connector [1]. Remove the bolts [2] and front combination light unit [3] while releasing the bosses [4] from the frame grommets [5].

Installation is in the reverse order of removal.

Refer to rear combination light removal (page 2-23).

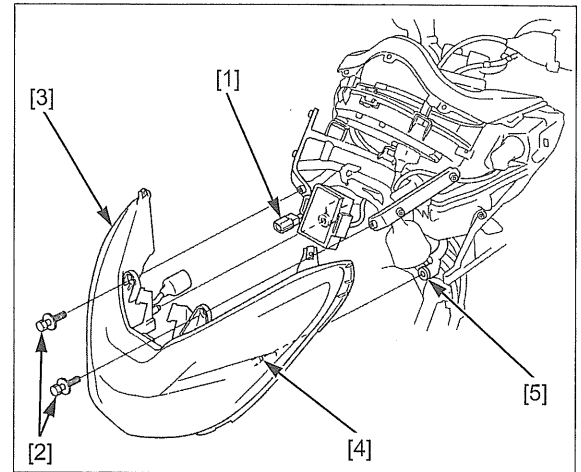

### INSPECTION

Turn the ignition switch ON.

Check that all the LEDs in the combination light unit illuminate.

If any LED except position light does not turn on, check the LED control unit (page 21-28).

If the position light does not turn on, replace the combination light unit.

## TURN SIGNAL LIGHT ('13 MODEL)

### BULB REMOVAL/INSTALLATION

- The bulb replacement procedure is the same for front and rear turn signal light.

Remove the screw [1] and turn signal light lens [2] by releasing the hook [3] from the turn signal light unit [4].

Remove the rubber seal [5].

Slightly push and turn the turn signal light bulb [6] counterclockwise, then remove it from the bulb socket.

Check the rubber seal is in good condition, replace it if necessary.

Installation is in the reverse order of removal.

**TORQUE:** Front/rear turn signal light lens screw:  
0.9 N·m (0.09 kgf·m, 0.7 lbf·ft)

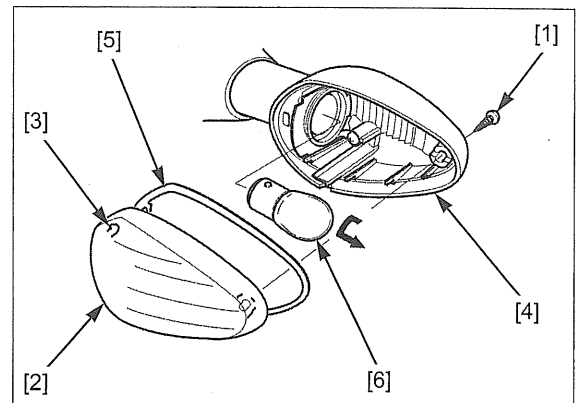

## LIGHTS/METERS/SWITCHES

### TURN SIGNAL LIGHT UNIT REMOVAL/INSTALLATION

- For front turn signal light unit removal/installation (page 2-17).

#### REAR

Remove the body cover (page 2-23).

Release the wire band [1]

Disconnect the following wire connectors [2]:

Right side:

- Light blue wire connector
- Green wire connector

Left side:

- Orange wire connector
- Green wire connector

Remove the nut [3] and set plate [4].

Remove the rear turn signal light unit [5] by pulling out the wire [6] from the holes of the rear fender.

Installation is in the reverse order of removal.

**TORQUE: Rear turn signal light unit mounting nut:**

**8.8 N·m (0.9 kgf·m, 6.5 lbf·ft)**

Right side shown:

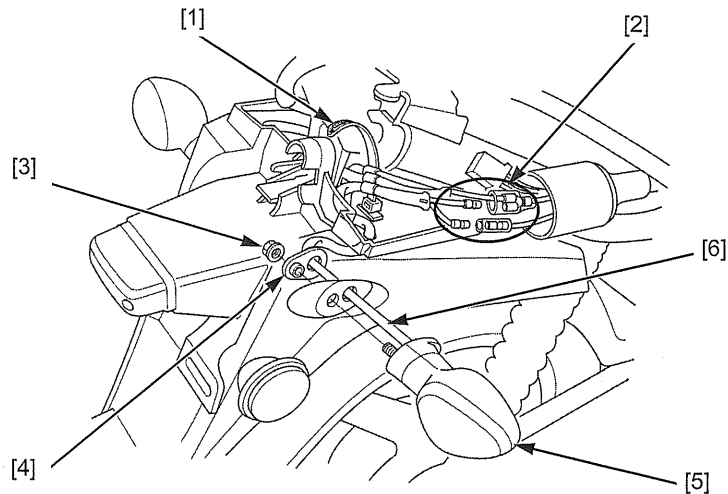

### TAIL/BRAKE LIGHT ('13 MODEL)

#### BULB REMOVAL/INSTALLATION

Remove the grab rail cover (page 2-20).

Turn the tail/brake light bulb socket [1] counterclockwise and pull it out from the light unit.

Slightly push and turn the tail/brake light bulb [2] counterclockwise, then remove it from the bulb socket.

Installation is in the reverse order of removal.

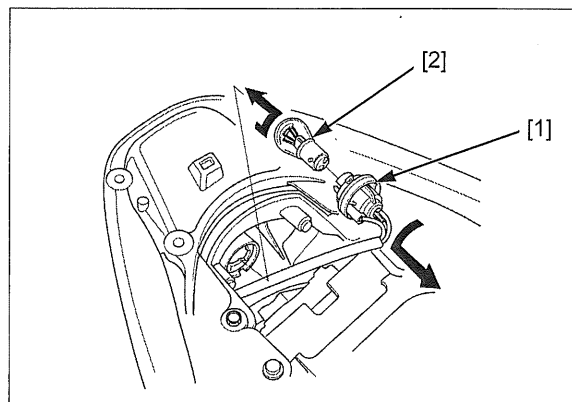

## LICENSE LIGHT

### BULB REPLACEMENT

Remove the screws [1].  
 Remove the license light lens [2] backward.  
 Remove the license light bulb from the socket [3].  
 Installation is in the reverse order of removal.

**TORQUE: License light lens screw:**  
 1 N·m (0.1 kgf·m, 0.7 lbf·ft)

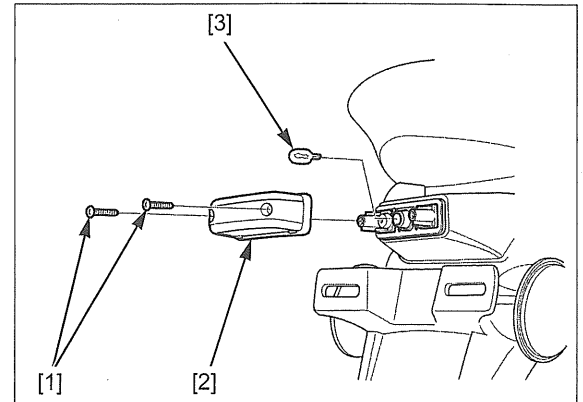

### LICENSE LIGHT UNIT REMOVAL/INSTALLATION ('13 MODEL)

Remove the body cover (page 2-23).  
 Release the wire band [1].  
 Disconnect the Brown and Green wire connectors [2]:  
 Remove the two nuts [3] and license light unit [4].  
 Installation is in the reverse order of removal.

**TORQUE: License light unit mounting nut:**  
 4.3 N·m (0.44 kgf·m, 3.2 lbf·ft)

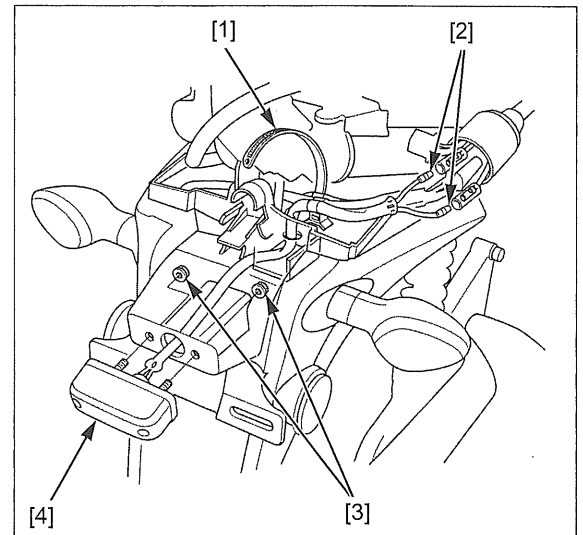

### LICENSE LIGHT UNIT REMOVAL/INSTALLATION (AFTER '13 MODEL)

Remove the body cover (page 2-23).  
 Disconnect 3P connector [1].  
 Release the wire clamp [2].  
 Remove the two screws [3] and license light unit [4].  
 Installation is in the reverse order of removal.

**TORQUE:**  
**License light unit mounting screw:**  
 1.2 N·m (0.12 kgf·m, 0.9 lbf·ft)

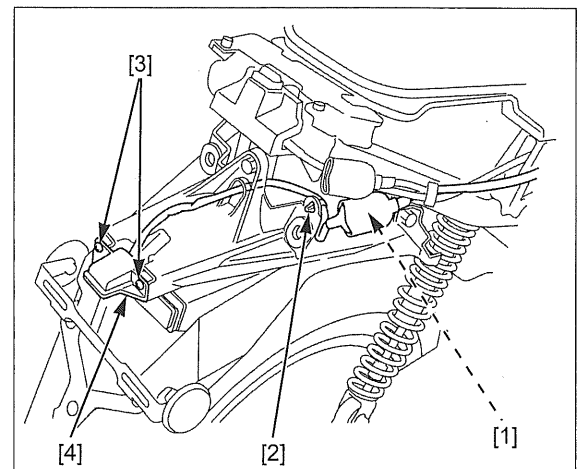

## LIGHTS/METERS/SWITCHES

### LICENSE LIGHT UNIT INSPECTION (AFTER '13 MODEL)

Turn the ignition switch ON.

Check that all the LEDs in the license light unit illuminate.

If any LED does not turn on, replace the license light (page 21-9).

## SPEEDOMETER ('13 MODEL)

### REMOVAL/INSTALLATION

Remove the rear meter panel (page 2-14).

Remove the four screws [1] and speedometer [2] from the rear meter panel [3].

Installation is in the reverse order of removal.

**TORQUE: Speedometer mounting screw:**  
1.1 N·m (0.11 kgf·m, 0.8 lbf·ft)

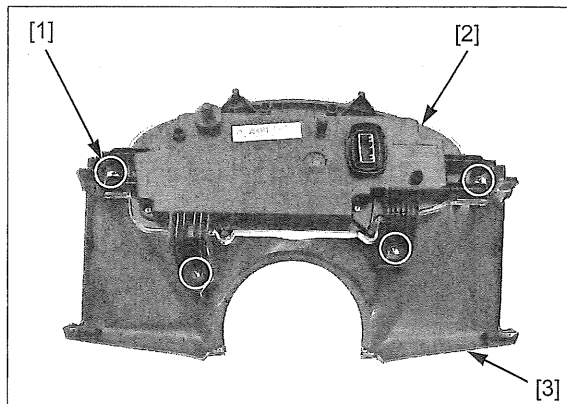

### DISASSEMBLY/ASSEMBLY

Remove the four screws [1] and speedometer lens [2].

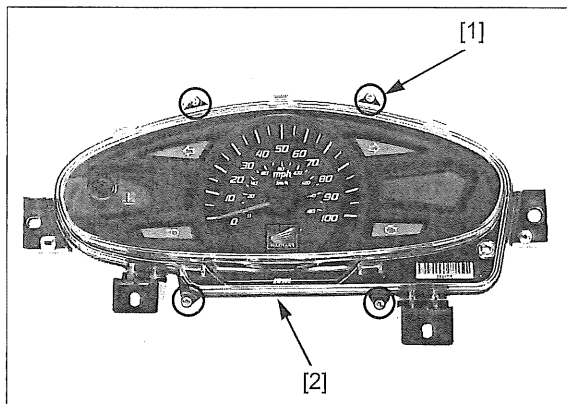

Remove the meter packing [1].

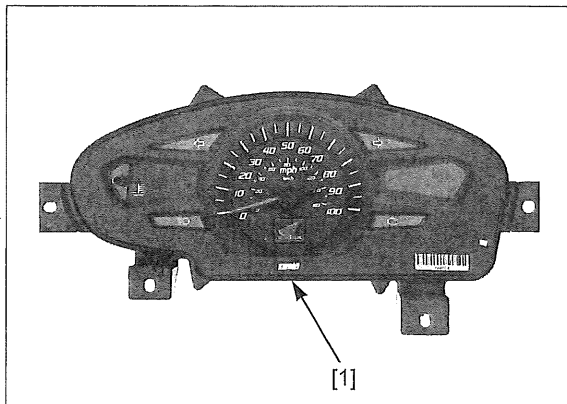

Remove the four screws [1] and speedometer panel from the lower case [2].

Assembly is in the reverse order of disassembly.

- Make sure the meter packing is in good condition and replace it if necessary.

**TORQUE: Speedometer screw:**  
0.54 N·m (0.06 kgf·m, 0.4 lbf·ft)

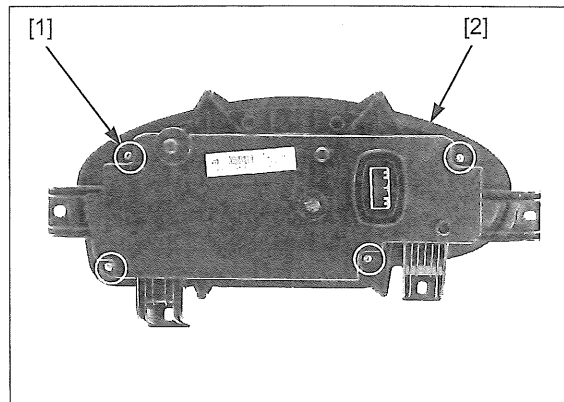

### INSPECTION

#### POWER/GROUND LINE

Remove the front meter panel (page 2-7).

Disconnect the speedometer 20P connector [1].

Turn the ignition switch ON and engine stop switch "O". Measure the voltage between the speedometer 20P connector of the wire harness side.

**CONNECTION: Brown (+) – Green/red (–)**  
**STANDARD: Battery voltage**

If there is battery voltage, the meter power/ground line is normal.

If there is no voltage, inspect the following:

- Blown SPEEDOMETER TAIL fuse (10 A)
- Loose or poor contacts of related terminal
- Open circuit in the Brown wire between the fuse box and speedometer
- Open circuit in the Green/red wire between the speedometer and ground

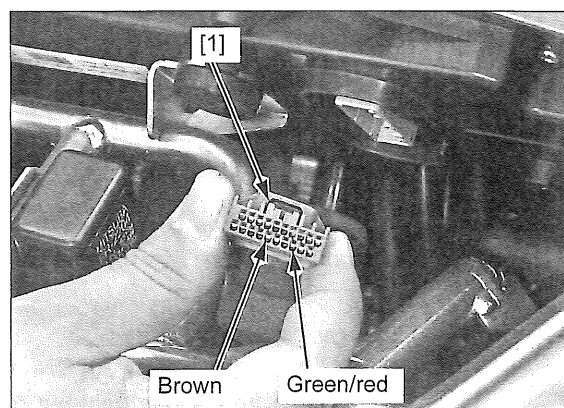

#### BACK-UP LINE

Remove the front meter panel (page 2-7).

Disconnect the meter 20P connector [1].

Measure the voltage between the speedometer 20P connector of the wire harness side and ground.

**CONNECTION: Light green/black (+) – Ground (–)**  
**STANDARD: Battery voltage**

If there is battery voltage at all times, the back-up line is normal.

If there is no voltage, inspect the following:

- Blown BACK UP fuse (10 A)
- Loose or poor contacts of related terminal
- Open circuit in the Light green/black wire between the fuse box and speedometer

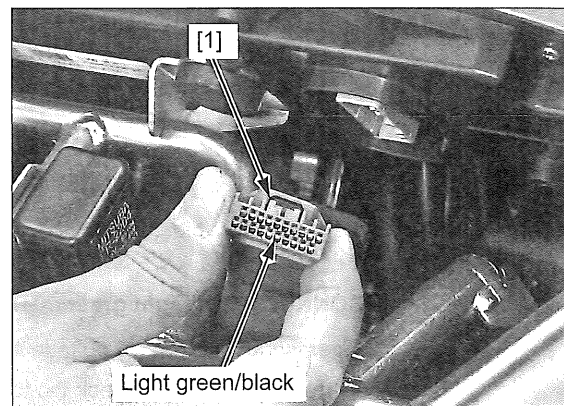

# COMBINATION METER (AFTER '13 MODEL)

## INITIAL OPERATION CHECK

When the ignition switch is turned ON, the combination meter will show the entire digital display and the speedometer needle [1] moves to full scale and then returns to zero.

If the combination meter does not show the initial operation, check the combination meter power and ground lines (page 21-12).

If the power and ground lines are OK, replace the combination meter assembly (page 21-14).

AC type shown:

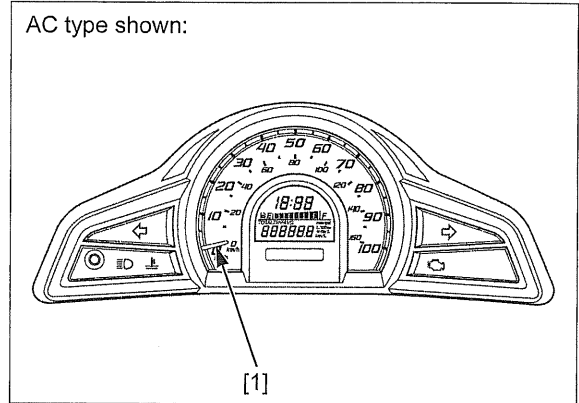

## POWER/GROUND LINE INSPECTION

Turn the ignition switch OFF.

Disconnect the combination meter 16P connector (page 2-14).

Check the following at the combination meter 16P connector of the wire harness side.

### POWER INPUT LINE

Turn the ignition switch ON.

Measure the voltage between the combination meter 16P connector [1] and ground.

**CONNECTION: Brown (+) – Ground (-)**

There should be battery voltage.

If there is no voltage, check the following:

- Open circuit in the Brown wire
- Blown IGN/INJ/F\_PUMP fuse (10 A)

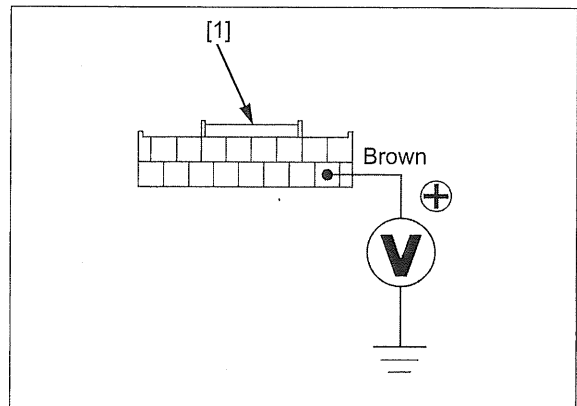

### BACK-UP VOLTAGE LINE

Measure the voltage between the combination meter 16P connector [1] and ground.

**CONNECTION: Light green/black (+) – Ground (-)**

There should be battery voltage at all times.

If there is no voltage, check the following:

- Open circuit in the Light green/black wire
- Blown BACK UP fuse (10 A)

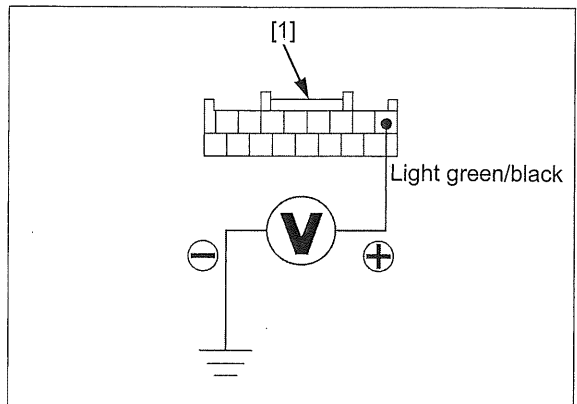

**GROUND LINE**

Check for continuity between the combination meter 16P connector [1] and ground.

**CONNECTION: Green – Ground**

There should be continuity at all times.

If there is no continuity, check for open circuit in Green wire.

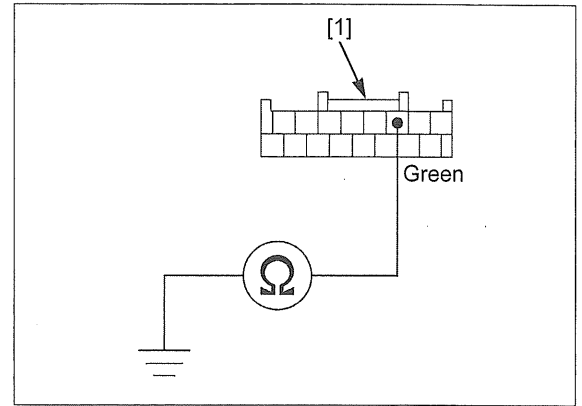

**SERIAL COMMUNICATION LINE INSPECTION**

Turn the ignition switch ON, check the combination meter.

The serial communication line is abnormal if the MIL [1] stays on.

Check the serial communication line in the following sequence.

AC type shown:

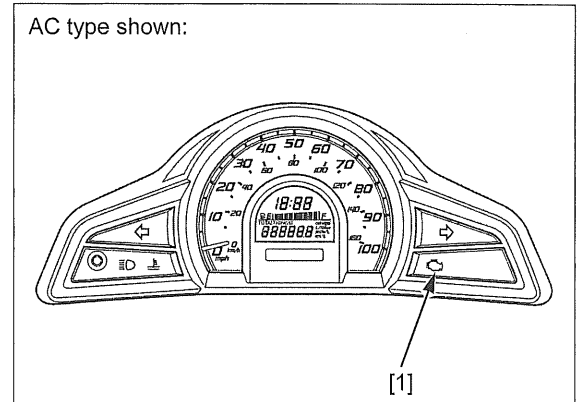

**1. Serial Communication Line Short Circuit Inspection**

Turn the ignition switch OFF.

Disconnect the following:

- Combination meter 16P connector (page 2-14)
- ECM 33P (Black) connector (page 4-49)

Check for continuity between the combination meter 16P connector [1] of the wire harness side and ground.

**Connection: Light green – Ground**

*Is there continuity?*

**YES** – Short circuit in the Light green wire

**NO** – GO TO STEP 2.

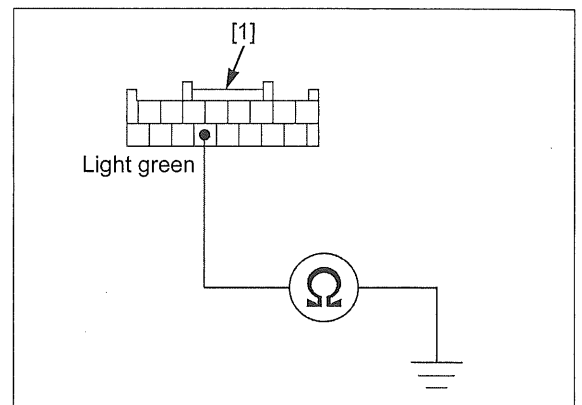

## LIGHTS/METERS/SWITCHES

### 2. Serial Communication Line Open Circuit Inspection

Check for continuity between the ECM 33P (Black) connector [1] and combination meter 16P connector [2] of the wire harness side.

**Connection: A15 – Light green**

**TOOL:**

Test probe, 2 pack                      07ZAJ-RDJA110

*Is there continuity?*

**YES** – Loose or poor contact on the related connectors.

**NO** – Open circuit in the Light green wire

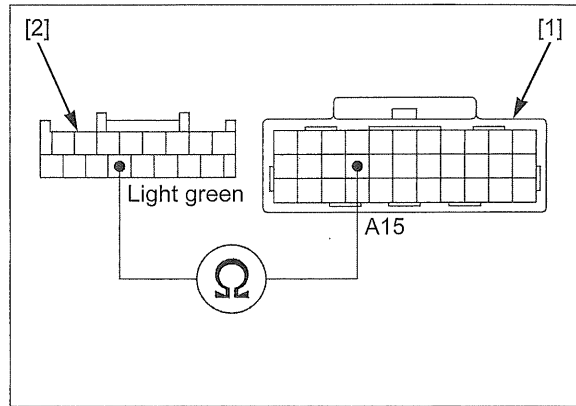

### REMOVAL/INSTALLATION

Remove the rear meter panel (page 2-14).

Remove the four screws [1] and combination meter [2] from the rear meter panel [3].

Installation is in the reverse order of removal.

**TORQUE:**

**Combination meter mounting screw:**  
1.2 N·m (0.12 kgf·m, 0.9 lbf·ft)

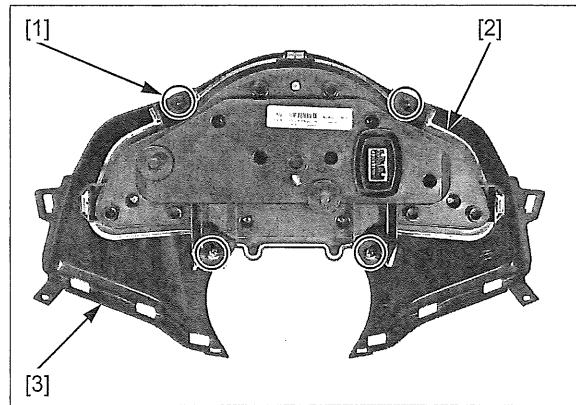

### DISASSEMBLY/ASSEMBLY

Remove the two screws [1], meter lens [2], and meter packing [3].

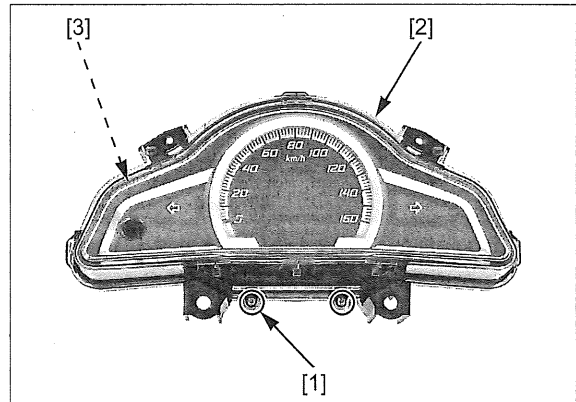

Remove the seven screws [1] and combination meter panel [2] from the lower case [3].

Assembly is in the reverse order of disassembly.

- Make sure the meter packing is in good condition and replace it if necessary.

**TORQUE:**

**Combination meter screw:**  
1.2 N·m (0.12 kgf·m, 0.9 lbf·ft)

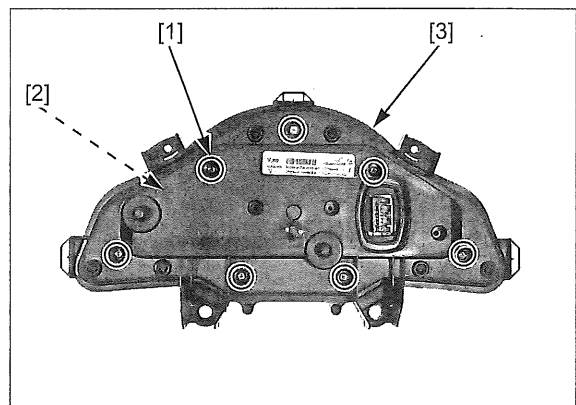



## FUEL GAUGE (AFTER '13 MODEL)

### INSPECTION

If the fuel gauge displays the circuit faulty pattern as shown with ignition switch is ON, check for open or short circuit in the Yellow/white wire between the combination meter and fuel pump unit.

If the Yellow/white wire is OK, check the fuel level sensor (page 21-19).

If the fuel level sensor is OK, replace the combination meter assembly (page 21-14).

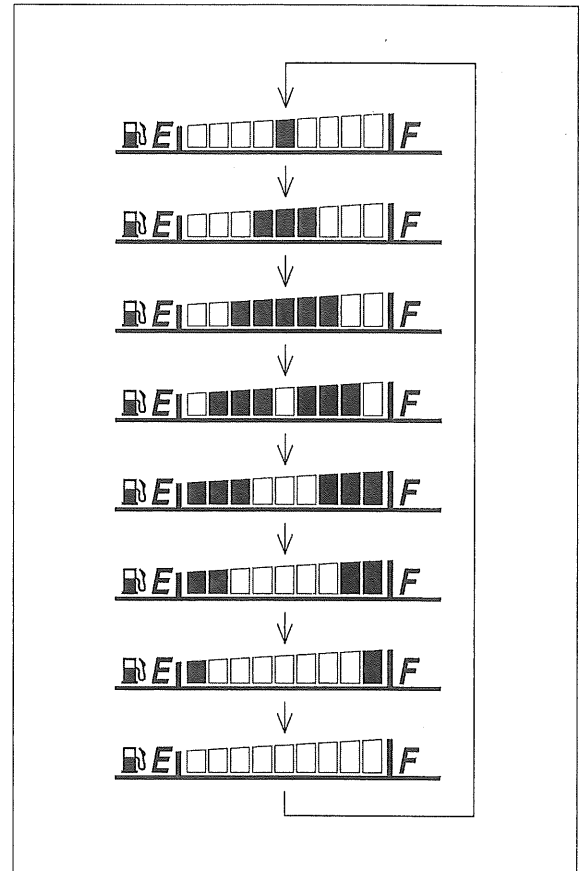

## AVERAGE FUEL MILEAGE (AFTER '13 MODEL)

### INSPECTION

Check the combination meter initial operation (page 21-12).

#### 1. Fuel Pulse Line Open Circuit Inspection

Turn the ignition switch OFF.

Remove the rear meter panel (page 2-14).

Disconnect the following:

- Combination meter 16P connector (page 2-14)
- ECM 33P (Black) connector (page 4-49)

Check the continuity between the ECM 33P (Black) connector [1] and combination meter 16P connector [2] of the wire harness side.

#### TOOL:

Test probe, 2 pack 07ZAJ-RDJA110

CONNECTION: A4 - Pink

*Is there continuity?*

**YES** - GO TO STEP 2.

**NO** - Open circuit in the Pink wire

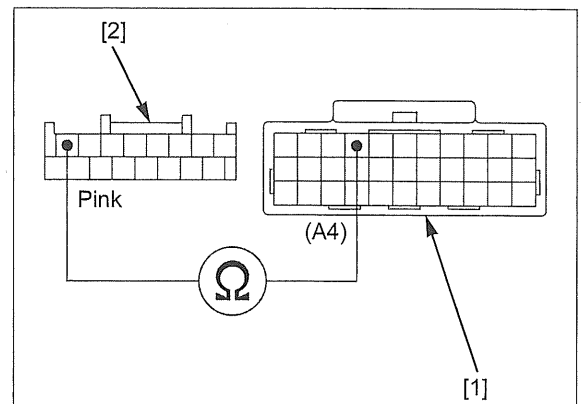

## LIGHTS/METERS/SWITCHES

### 2. Fuel Pulse Line Short Circuit Inspection

Check the continuity between the combination meter 16 P connector [1] of the wire harness side.

**CONNECTION: Pink – Ground**

*Is there continuity?*

**YES** – Short circuit in the Pink wire

**NO** – Faulty ECM

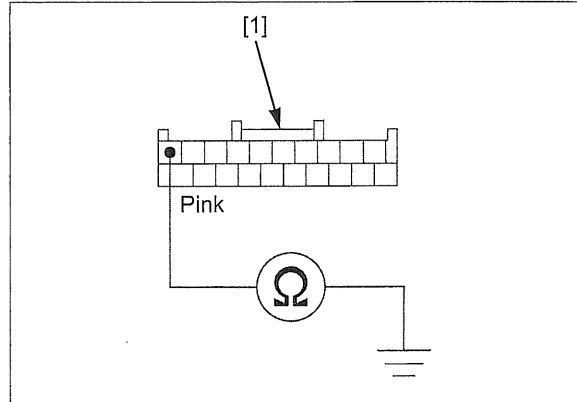

## VS SENSOR

### REMOVAL/INSTALLATION

Remove the air cleaner housing (page 7-13).

Remove the two socket bolts [1] from the sensor protector [2].

Remove the sensor protector while releasing the grommet [3] of the protector from the boss [4] of the left crankcase.

Release the wire band bosses [5] from the sensor protector.

- When installing the socket bolt, clean the threads and apply locking agent to the bolt threads.

**TORQUE: VS sensor protector socket bolt:  
10 N·m (1.0 kgf·m, 7 lbf·ft)**

Disconnect the VS sensor 3P (Black) connector [1].  
Remove the bolt [2] and VS sensor [3].

Remove the O-ring [4] from the VS sensor groove.

Installation is in the reverse order of removal.

- Replace the O-ring with a new one and coat it with engine oil.

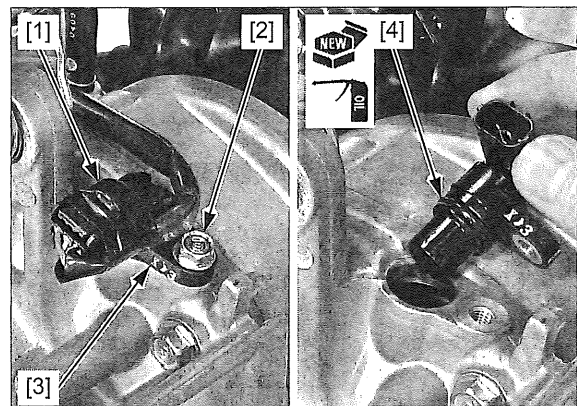
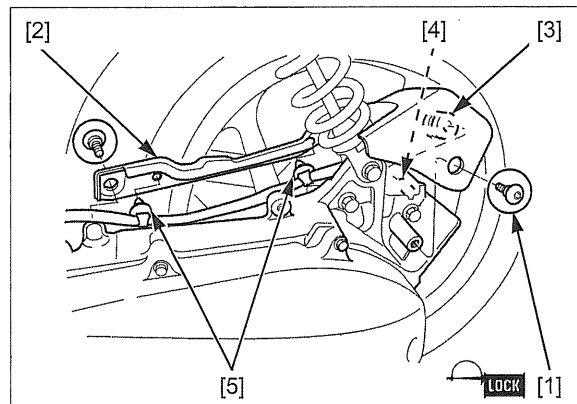

**INSPECTION**

**SPEEDOMETER NEEDLE DOES NOT MOVE**

Remove the following:

- Front meter panel (page 2-7)
- VS sensor protector (page 21-16)

Disconnect the VS sensor 3P (Black) connector [1].

Turn the ignition switch ON and engine stop switch "O". Measure the voltage between the 3P (Black) connector of the wire harness side.

**CONNECTION: Black/white (+) – Blue/green (-)**  
**STANDARD: Battery voltage**

If there is battery voltage, the power/ground line is normal.

If there is no voltage, inspect the following:

- Loose or poor contacts of related terminal
- Open circuit in the Black/white wire between the ignition switch and VS sensor
- Open circuit in the Blue/green wire between the ECM and VS sensor

Turn the ignition switch OFF.

Disconnect the speedometer 20P connector [1].

Check the continuity between the speedometer 20P connector and VS sensor 3P (Black) connector [2] of the wire harness side.

Check the continuity between the VS sensor 3P (Black) connector of the wire harness side and ground.

CONNECTION	STANDARD
Pink/green – Pink/green	Continuity
Pink/green – Ground	No Continuity

If the above inspection are abnormal, check for an open or short circuit in the Pink/green wire.

If the above inspection are normal, replace the VS sensor with a new one and recheck.

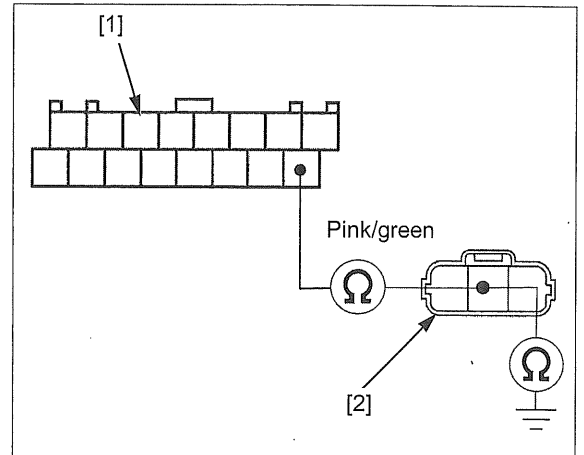
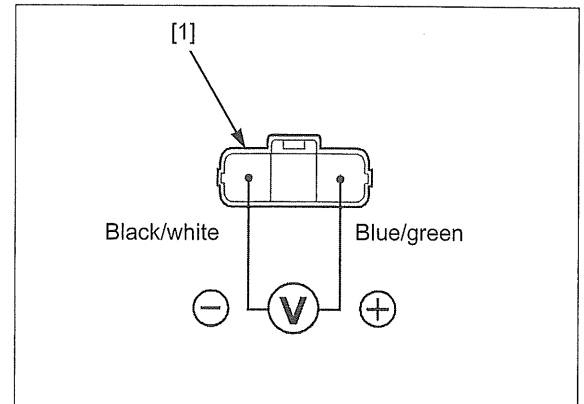

## COOLANT TEMPERATURE INDICATOR

### SYSTEM INSPECTION ('13 MODEL)

- Coolant temperature indicator turns on when the coolant temperature becomes higher and lower than certain temperature.
- Before performing the system inspection, make sure that the following items are normal.
  - Cooling system flow
  - Other meter indicators
  - No MIL blinking (page 4-10)

Turn the ignition switch ON and engine stop switch "O", check the coolant temperature indicator.

When the engine is cold, the indicator should not come on.

Turn the ignition switch OFF.

Disconnect the ECM 21P (Black) connector (page 4-49).

Turn the ignition switch ON and check the indicator. The indicator should not come on.

If the indicator comes on, check the following:

- Light green/red wire between the meter and ECM for a short circuit
- speedometer panel for an internal short circuit

If the indicator goes off with the connector disconnected, check the following:

Short the ECM 21P (Black) connector [1] terminal of the wire harness side and ground with the jumper wire [2].

**CONNECTION: Light green/red – Ground**

**TOOL:**

**Test probe, 2 pack                      07ZAJ-RDJA110**

Turn the ignition switch ON and check the indicator. The indicator should come on.

If the indicator does not come on, check the following:

- Light green/red wire between the meter and ECM for open circuit
- speedometer panel for internal open circuit

If above inspections are normal, replace the ECM with a new one and recheck.

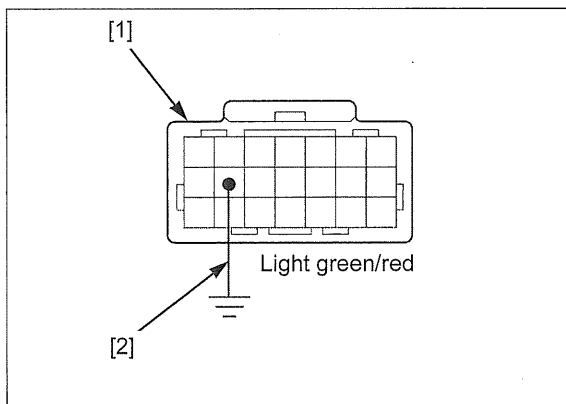

### SYSTEM INSPECTION (AFTER '13 MODEL)

If the high coolant temperature indicator does not operate properly, check the following:

- Combination meter system inspection (page 21-7)
- Serial communication line (page 21-13)
- MIL blinking: If the MIL blinks 7, check the ECT sensor system (page 4-20).
- ECT sensor (page 4-52)

If the above items are OK, replace the combination meter assembly (page 21-14).

# FUEL METER/FUEL LEVEL SENSOR

## SYSTEM INSPECTION

### WHEN THE FUEL METER BLINKS RAPIDLY

Before performing the system inspection, check the following:

- Battery condition
- Burned fuse

Disconnect the fuel pump 5P connector (page 7-6).

Short the fuel pump 5P connector [1] terminals of the wire harness side with the jumper wire.

**CONNECTION: Yellow/white – Blue/green**

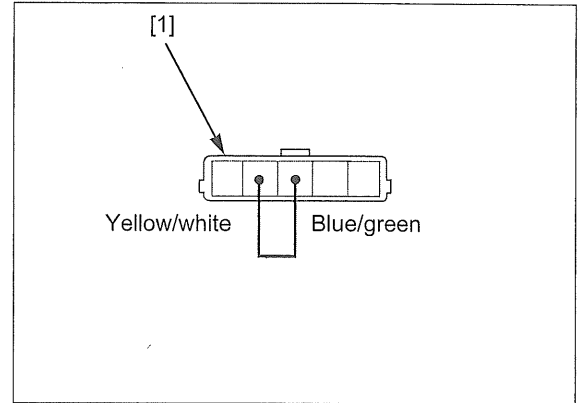

*Do not leave the terminals connected with jumper wire for a long time, as it causes damage to the fuel meter.*

Turn the ignition switch ON and engine stop switch "O", check the fuel meter.

The fuel meter blinks slowly if the system circuit is normal.

In that case, check the fuel level sensor (page 21-19).

If the meter blinks rapidly, check the following:

- Yellow/white wire between the fuel pump/fuel level sensor and speedometer for an open circuit
- Blue/green wire between the fuel pump/fuel level sensor and ECM for an open circuit

If the wire is normal, replace the speedometer panel with a new one and recheck.

### WHEN THE FUEL METER BLINKS SLOWLY

Disconnect the fuel pump 5P connector (page 7-6).

Turn the ignition switch ON and engine stop switch "O", check the fuel meter.

The fuel meter blinks rapidly if the system circuit is normal.

In that case, check the fuel level sensor (page 21-19).

If the meter blinks slowly, check the Yellow/white wire between the fuel pump/fuel level sensor and speedometer for a short circuit

If the wire is normal, replace the speedometer panel with a new one and recheck.

## FUEL LEVEL SENSOR INSPECTION

'13 model: Remove the fuel pump unit (page 7-10).

Measure the resistance between the connector terminals at the float upper (full) and lower (empty) positions.

**CONNECTION: A – B**

(20 °C/68 °F)

FLOAT POSITION	FULL	EMPTY
RESISTANCE	6 – 10 Ω	90 – 100 Ω

Replace the fuel level sensor if it is out of specification (page 21-20).

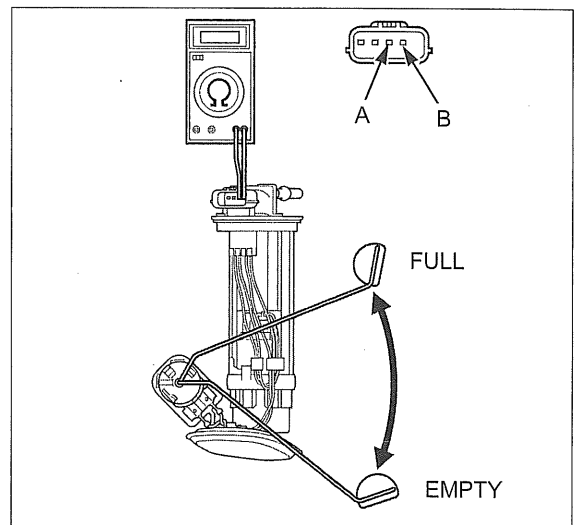

## LIGHTS/METERS/SWITCHES

After '13 model: Remove the fuel pump unit (page 7-10).

Measure the resistance between the connector terminals at the float upper (full) and lower (empty) positions.

**CONNECTION: A – B**

FLOAT POSITION	FULL	EMPTY
RESISTANCE	5 – 11 $\Omega$	265 – 275 $\Omega$

Replace the fuel level sensor if it is out of specification (page 21-20).

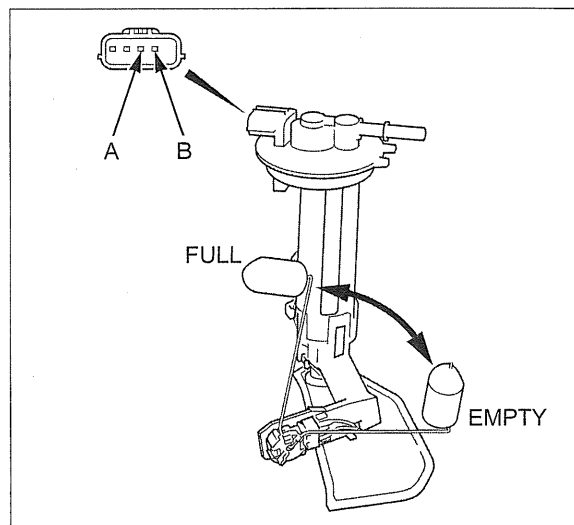

### FUEL LEVEL SENSOR REMOVAL/INSTALLATION

Remove the fuel pump unit (page 7-10).

Disconnect the fuel level sensor Red and Black wire connectors.

Release the wires from the guides [1] of the fuel pump unit.

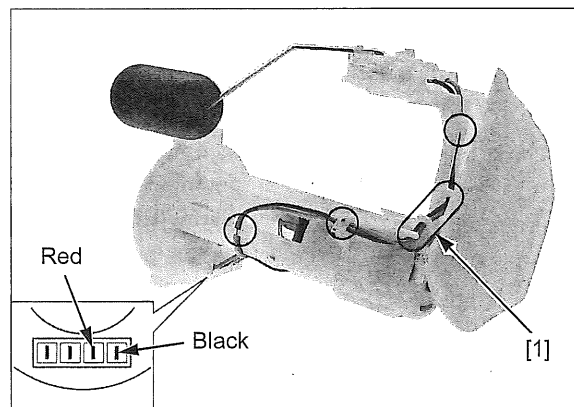

Remove the fuel level sensor [1] from the fuel pump unit by releasing the three hooks [2].

Installation is in the reverse order of the removal.

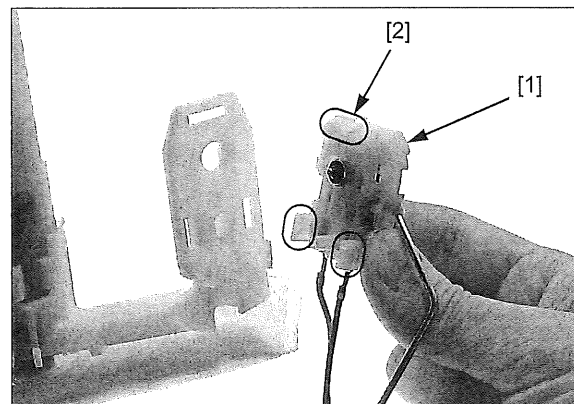

## IGNITION SWITCH

### FUEL LID/SEAT OPENER REMOVAL/ INSTALLATION

Remove the inner cover (page 2-13).

Remove the screw [1] and fuel lid/seat opener lower cover [2] by releasing its hooks [3].

**TORQUE:**

**Fuel lid/seat opener lower cover screw:**  
1.1 N·m (0.11 kgf·m, 0.8 lbf·ft)

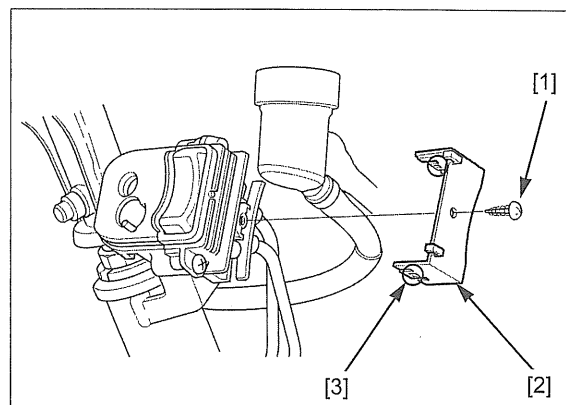

Disconnect the fuel lid cable [1] and seat opener cable [2] from the cable levers [3].

Remove the two screws [4] and fuel lid/seat opener [5] from the ignition switch.

Installation is in the reverse order of removal.

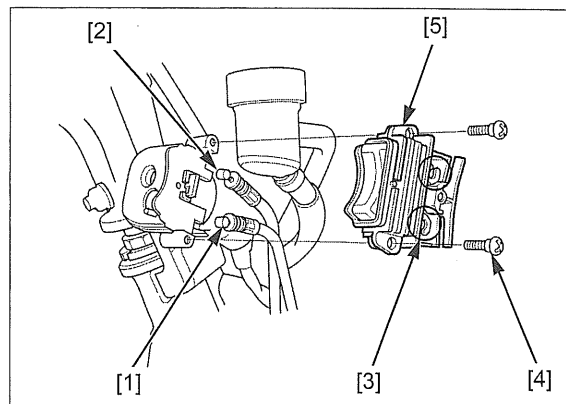

### IGNITION SWITCH REMOVAL

Remove the steering stem (page 17-24).

Disconnect the ignition switch 2P connector [1].

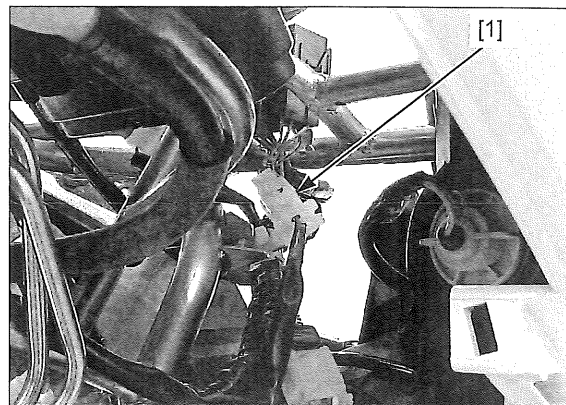

Remove the screws [1] and ignition switch [2].

Remove the socket bolt [3] and key shutter [4].

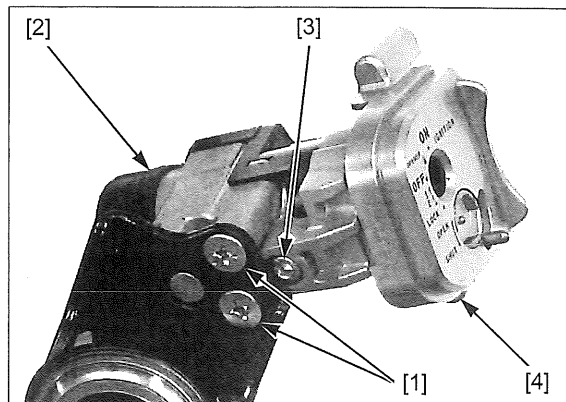

## LIGHTS/METERS/SWITCHES

### INSTALLATION

Install the key shutter [1] while aligning the grooves [2] of the ignition switch [3] with the tabs [4] on the key shutter.

Turn the ignition switch as shown.

Install and tighten the socket bolt [5] to the specified torque.

**TORQUE: 5.1 N·m (0.52 kgf·m, 3.8 lbf·ft)**

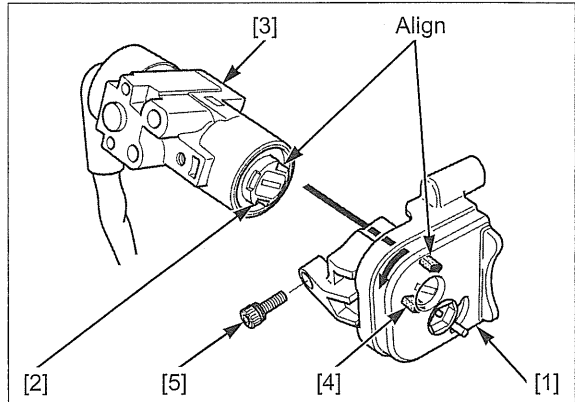

Install the ignition switch [1] by aligning the boss and hole of the frame.

Install and tighten a new screws [2] to the specified torque.

**TORQUE: 9 N·m (0.9 kgf·m, 6.6 lbf·ft)**

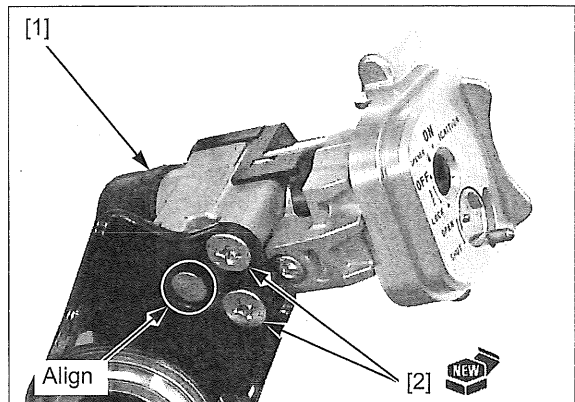

Connect the ignition switch 2P connector [1].

Install the steering stem (page 17-27).

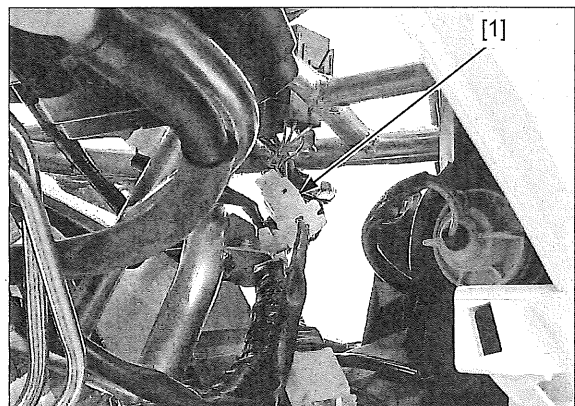

### INSPECTION

Remove the front meter panel (page 2-7).

Disconnect the ignition switch 2P connector [1].

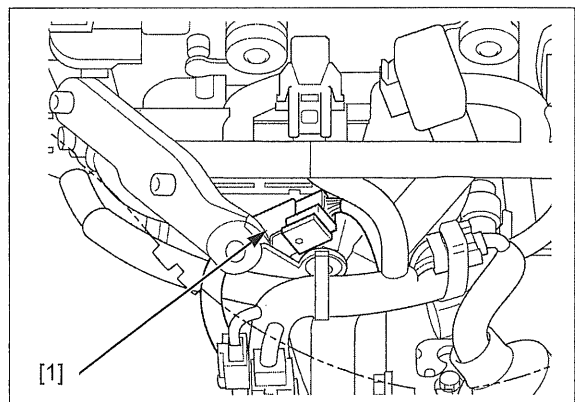



## LIGHTS/METERS/SWITCHES

Check for continuity at the terminals of the switch side connector in each switch position.

Continuity should exist between the color coded wires as follows:

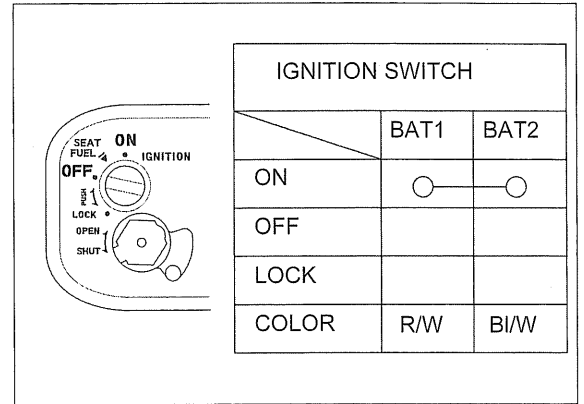

# HANDLEBAR SWITCHES

## HANDLEBAR SWITCH INSPECTION

Remove the inner cover (page 2-13).

Disconnect the following connectors [1]:

- Right handlebar switch 6P (Red) connector
- Right handlebar switch 3P (Red) connector
- Left handlebar switch 9P (Black) connector

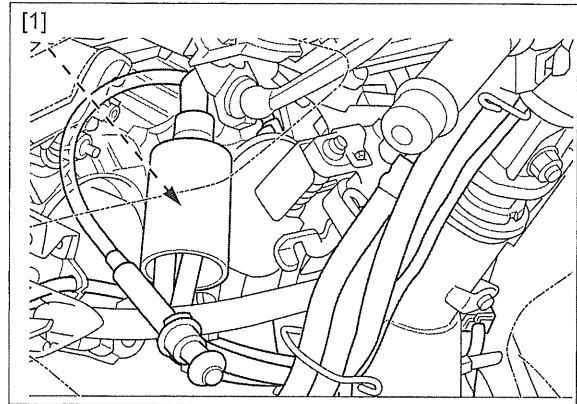

Check for continuity between the terminals of the starter switch and engine stop switch connector in each switch position.

Continuity should exist between the color coded wires as follows:

DIMMER SWITCH			
	HL	Lo	Hi
	<input type="radio"/>	<input type="radio"/>	
(N)	<input type="radio"/>	<input type="radio"/>	<input type="radio"/>
	<input type="radio"/>		<input type="radio"/>
COLOR	Bl/R	W	Bu

ENGINE STOP SWITCH		
	BAT	ECM
	<input type="radio"/>	<input type="radio"/>
COLOR	Bl/W	Bl/G

HORN SWITCH		
	BAT	HO
FREE		
PUSH	<input type="radio"/>	<input type="radio"/>
COLOR	Bl/Br	Lg

TURN SIGNAL LIGHT SWITCH			
	R	W	L
	<input type="radio"/>	<input type="radio"/>	
N			
		<input type="radio"/>	<input type="radio"/>
COLOR	Lb	Gr	O

STARTER SWITCH		
	ST	ECM
FREE		
PUSH	<input type="radio"/>	<input type="radio"/>
COLOR	G/Y	Y/G

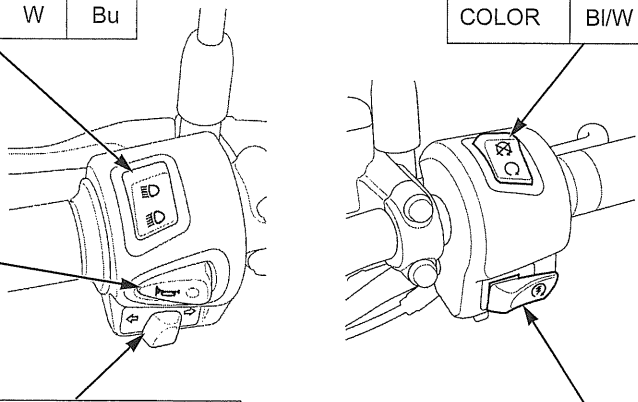

## BRAKE LIGHT SWITCH

### INSPECTION

#### FRONT

Disconnect the front brake light switch wire connectors [1] and check for continuity of the switch side terminals [2].

There should be continuity with the front brake lever squeezed, and there should be no continuity when the front brake lever is released.

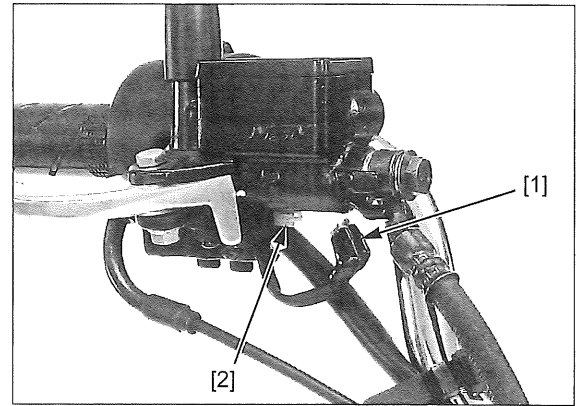

#### REAR

Remove the inner cover (page 2-13).

Disconnect the rear brake light switch wire connectors [1] and check for continuity at the wire connector terminals of the switch side.

#### CONNECTION: Black/brown – Green/yellow

There should be continuity with the rear brake lever squeezed, and there should be no continuity when the rear brake lever is released.

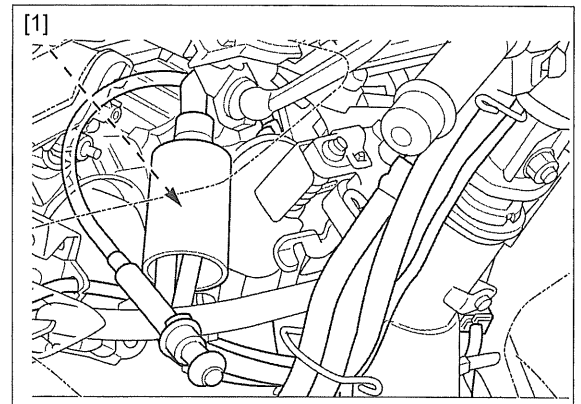

## HORN

### REMOVAL/INSTALLATION

Remove the left front cover (page 2-15).

Disconnect the horn connectors [1] from the horn [2]. Remove the bolt [3] and horn.

Installation is in the reverse order of removal.

- Align the horn bracket with the stopper of the frame bracket.

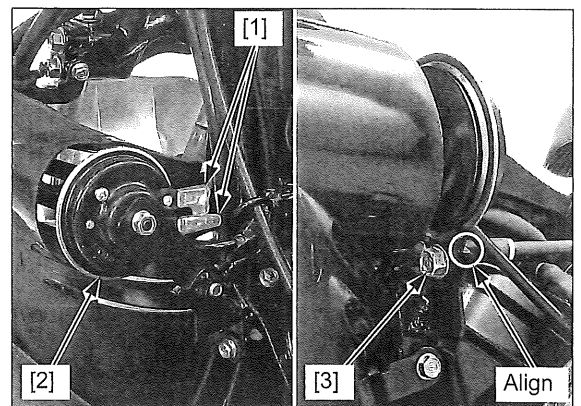

## LIGHTS/METERS/SWITCHES

### INSPECTION

Remove the center cover (page 2-10).

Disconnect the horn connectors from the horn [1].

Connect a 12 V battery to the horn terminals.  
The horn is normal if it sounds when the 12 V battery is connected to the horn terminals.

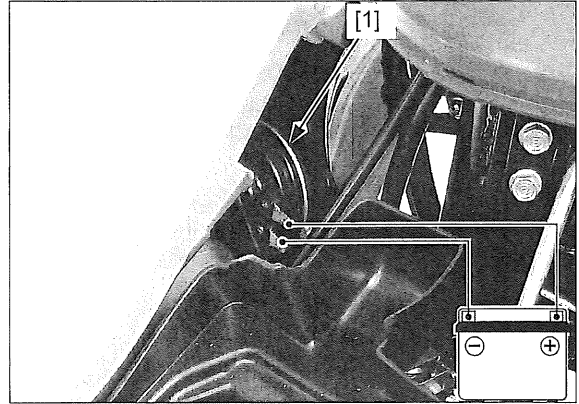

## ACCESSORY SOCKET (AFTER '13 MODEL)

### REMOVAL/INSTALLATION

Remove the front meter panel (page 2-7).

Disconnect the wire connector [1].

Remove the following:

- Accessory socket [2]
- Accessory socket cover [3]

*Align the locating lug on the socket with the cutout in the inner cover.*

Installation is in the reverse order of removal.

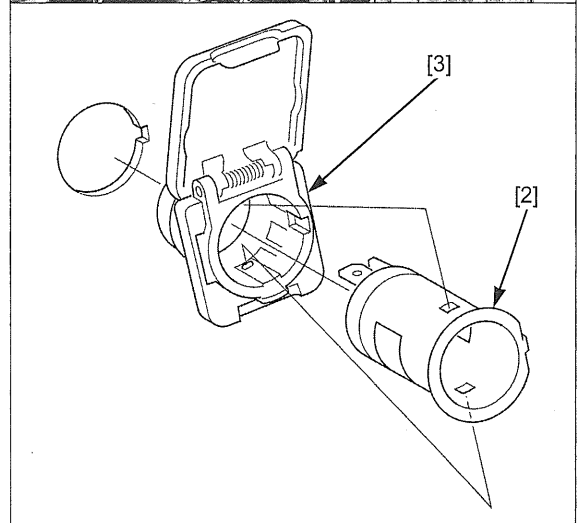
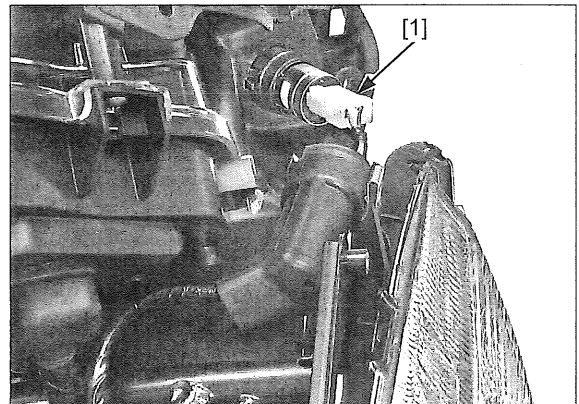

## MAIN RELAY

### REMOVAL/INSTALLATION

'13 model: Remove the front meter panel (page 2-7).

Remove the main relay [1] from the 4P (Gray) connector [2].

Installation is in the reverse order of removal.

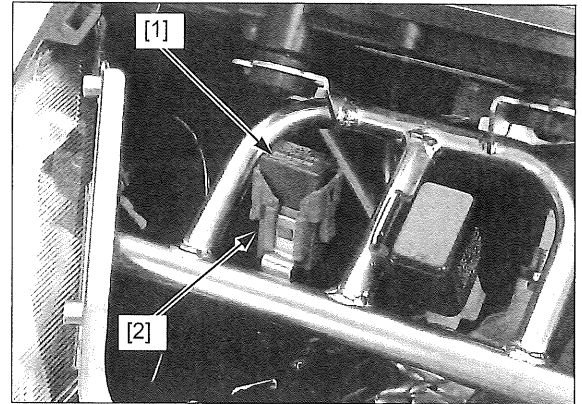

After '13 model: Remove the battery maintenance lid (page 20-7).

Remove the fuse box cover [1] and main relay [2].

Installation is in the reverse order of removal.

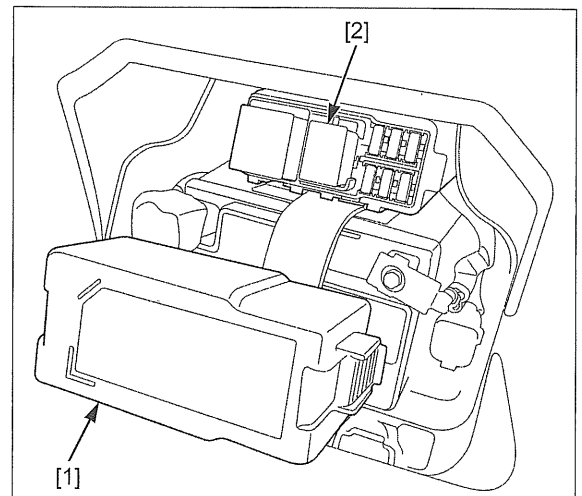

### CONTINUITY INSPECTION

Turn the ignition switch OFF.

Remove the main relay (page 21-27).

Connect an ohmmeter to the following relay [1] terminals.

#### CONNECTION: A - B

Connect the 12 V battery to the following relay terminals.

#### CONNECTION: C - D

There should be continuity between the relay terminals while the battery is connected, and no continuity when the battery is disconnected.

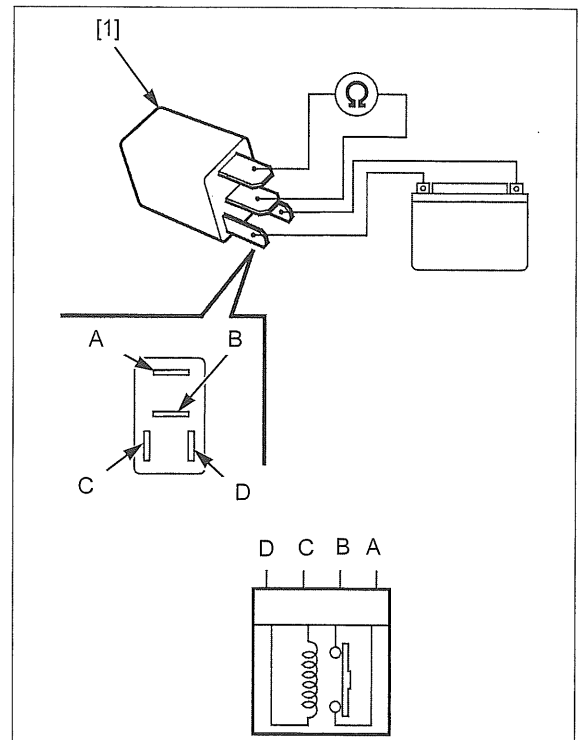

## TURN SIGNAL LIGHT RELAY ('13 MODEL)

### INSPECTION

Before performing the inspection, check the following:

- Battery condition
- Burned out bulb or non-specified wattage
- Blown WINKER, STOP HORN fuse (10 A)
- Turn signal switch function
- Loose connector
- Horn operation

Remove the front meter panel (page 2-7).

Disconnect the turn signal light relay 2P connector [1] from the relay [2].

Short the turn signal light relay 2P connector terminals of the wire harness side with a jumper wire.

### CONNECTION: Black/brown – Gray

Turn the ignition switch ON and engine stop switch "O".

Check the turn signal light by turning the switch ON.

If the light comes on, the turn signal light relay is faulty or connector has poor connection.

If the light does not come on, the wire harness is broken.

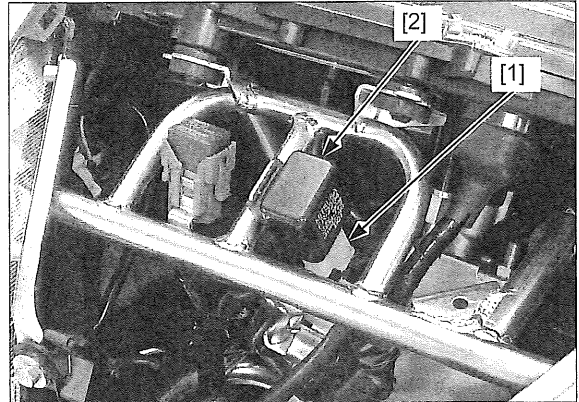

## LED CONTROL UNIT (AFTER '13 MODEL)

### REMOVAL/INSTALLATION

Remove the front meter panel (page 2-7).

Remove the LED control unit [1] with the rubber holder [2].

Disconnect the 20P (Gray) connector [3].

Remove the LED control unit from the rubber holder.

Installation is in the reverse order of removal.

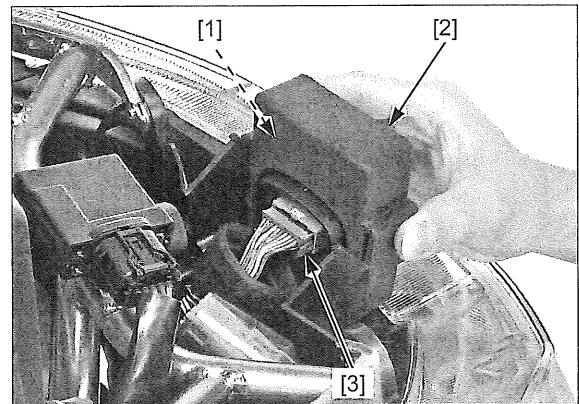

### INPUT VOLTAGE INSPECTION

Disconnect the LED control unit 20P (Gray) connector (page 21-28).

Turn the ignition switch ON.

Measure the voltage between the LED control unit 20P (Gray) connector [1] terminals of the wire harness side and ground.

**Connection: Brown – Green/brown  
Light green/black – Green/brown**

There should be battery voltage.

- If there is no battery voltage, check for open or short circuit in following wires:
  - Brown
  - Light green/black
  - Green/brown
- If there is battery voltage, inspect the output voltage (page 21-29).

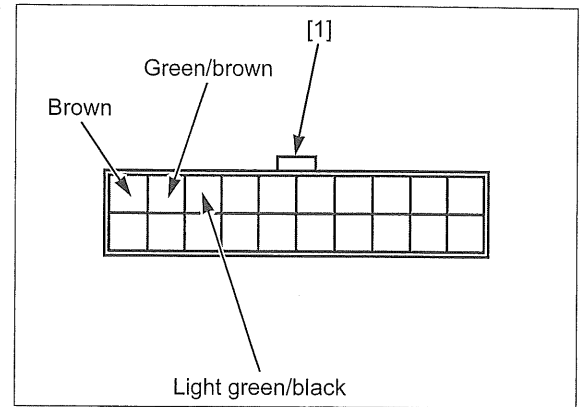

### OUTPUT VOLTAGE INSPECTION

#### FRONT COMBINATION LIGHT

Disconnect the front combination light 8P connector (page 21-7).

Turn the ignition switch ON.

*Use the special tool only for turn signal light voltage inspection.*

Measure the voltage between the front combination light 8P connector [1] terminals of the wire harness side and ground.

**TOOL:**

**Imrie diagnostic tester (model 625) or  
Peak voltage adaptor 07HGJ-0020100  
with commercially available digital multimeter  
(impedance 10 MΩ/DCV minimum)**

**Connection:**

- High beam: Blue/black (+) – Green/white (-)**
- Low beam: White/black (+) – Green/white (-)**
- Left turn signal light: Orange/black (+) – Green (-)**
- Right turn signal light: Light blue/black (+) – Green (-)**

If there is voltage, replace the front combination light with a new one (page 21-7).

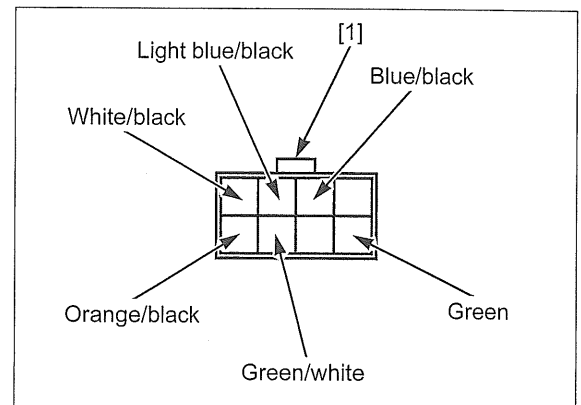

## LIGHTS/METERS/SWITCHES

### REAR COMBINATION LIGHT

Remove the grab rail (page 2-21).

Disconnect the rear combination light 9P connector (page 2-23).

Turn the ignition switch ON.

*Use the special tool only for turn signal light voltage inspection.*

Measure the voltage between the rear combination light 9P connector [1] terminals of the wire harness side and ground.

#### TOOL:

**Imrie diagnostic tester (model 625) or  
Peak voltage adaptor 07HGJ-0020100  
with commercially available digital multimeter  
(impedance 10 M $\Omega$ /DCV minimum)**

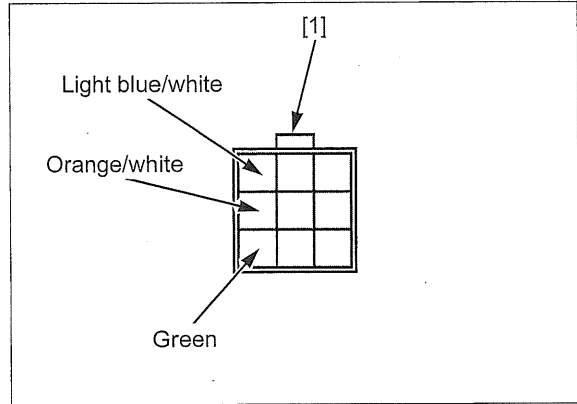

#### Connection:

**Left turn**

**signal light: Orange/white (+) – Green (-)**

**Right turn**

**signal light: Light blue/white (+) – Green (-)**

If there is voltage, replace the rear combination light with a new one (page 2-23).



---

**MEMO**

---

---

**MEMO**

---

# 22. WIRING DIAGRAM

---

WIRING DIAGRAM ('13 MODEL)..... 22-2

WIRING DIAGRAM  
(AFTER '13 MODEL) ..... 22-3





WIRING DIAGRAM ('13 MODEL)

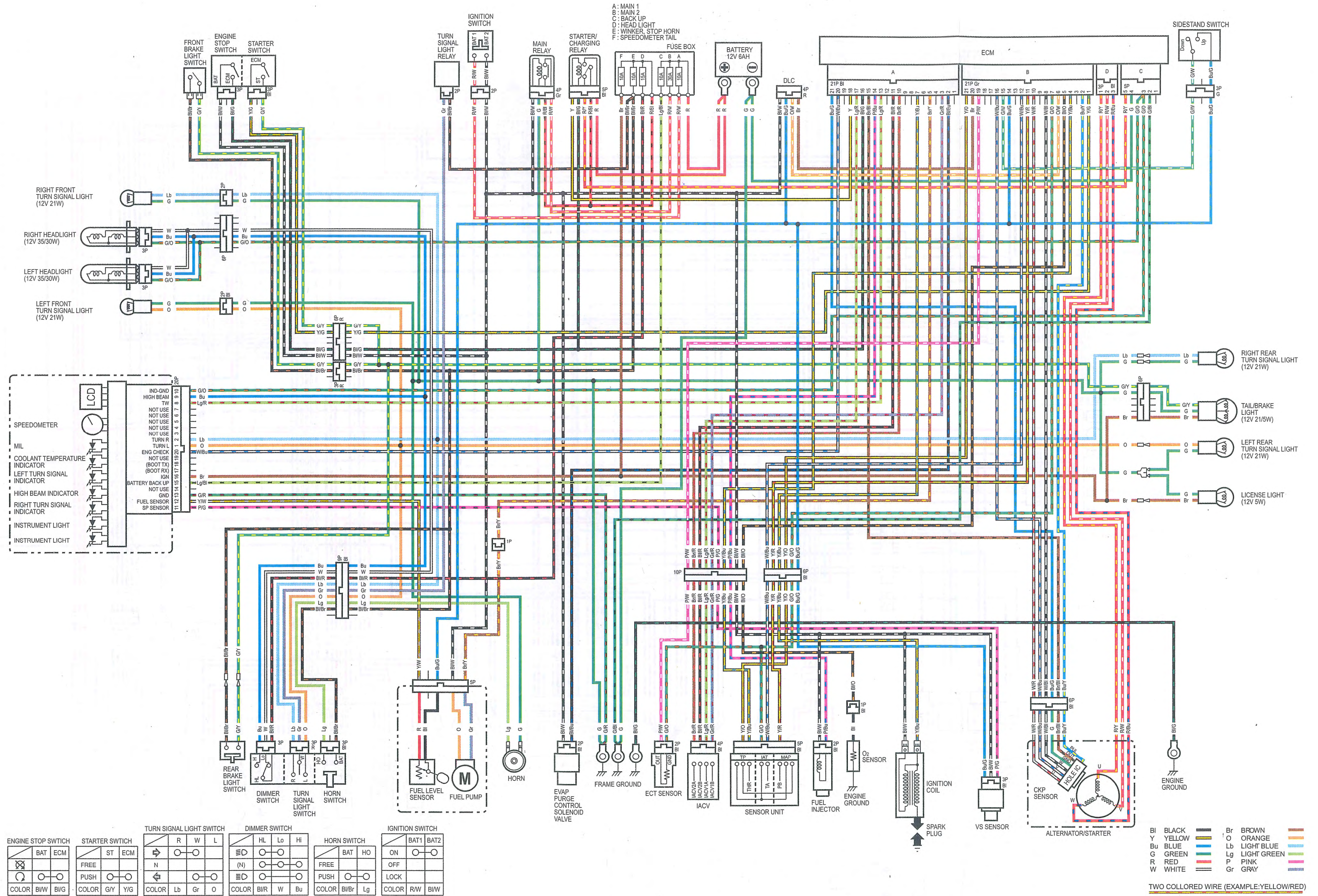

ENGINE STOP SWITCH			STARTER SWITCH			TURN SIGNAL LIGHT SWITCH			DIMMER SWITCH			HORN SWITCH			IGNITION SWITCH			
BAT	ECM		FREE	ST	ECM	R	W	L	HL	Lo	Hi	FREE	BAT	HO	BAT1	BAT2		
						N									ON	OFF		
															LOCK			
COLOR	BI/W	BI/G	COLOR	GY	Y/G	COLOR	Lb	Gr	O	COLOR	BI/R	W	Bu	COLOR	BI/B	Lg		







WIRING DIAGRAM

WIRING DIAGRAM (AFTER '13 MODEL)

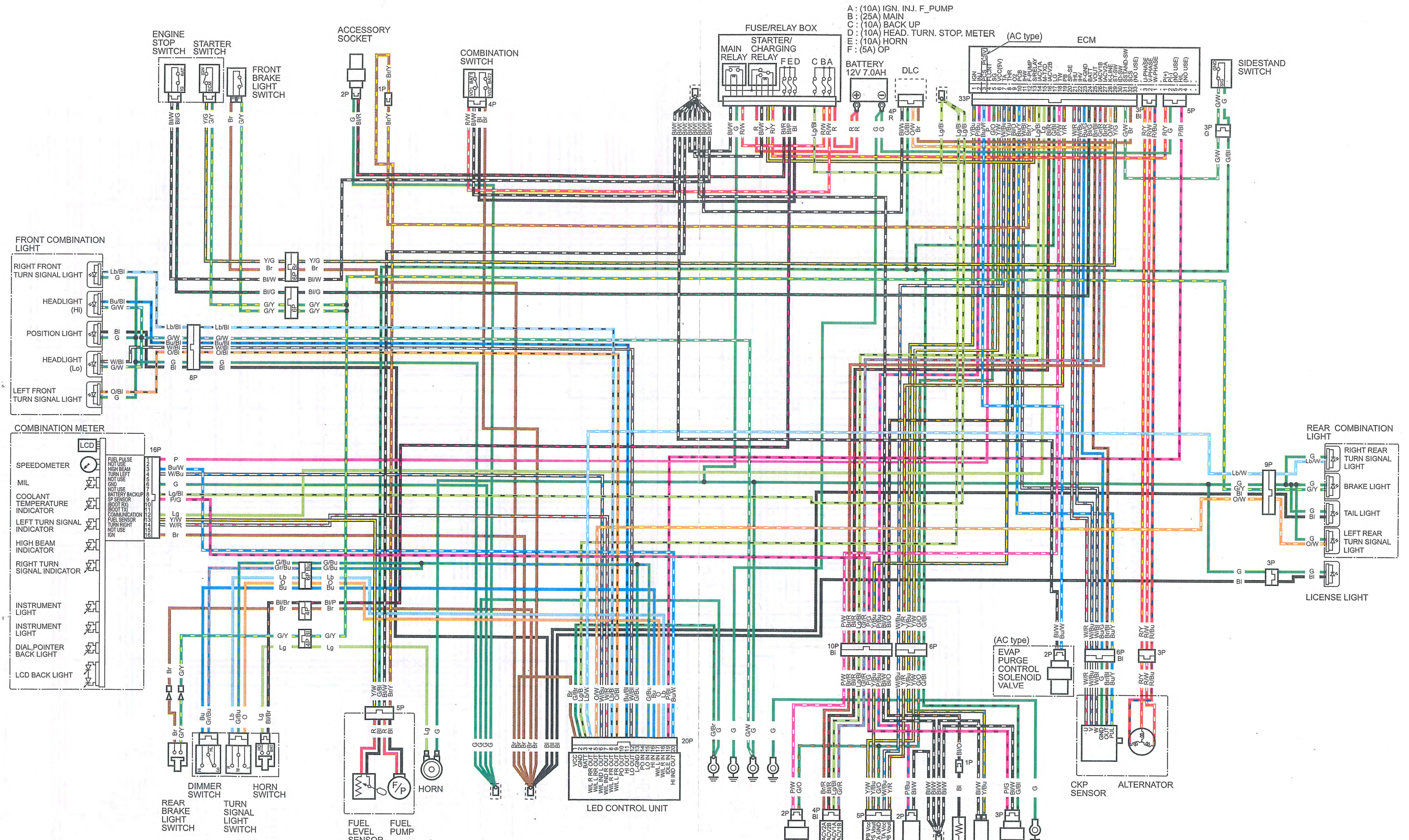

- A: (10A) IGN. INJ. F\_PUMP
- B: (25A) MAIN
- C: (10A) BACK UP
- D: (10A) HEAD. TURN. STOP. METER
- E: (10A) HORN
- F: (5A) OP

SWITCH CONTINUITY

COMBINATION SWITCH				STARTER SWITCH		DIMMER SWITCH			TURN SIGNAL LIGHT SWITCH			HORN SWITCH		SIDESTAND SWITCH		ENGINE STOP SWITCH					
BAT1	VO1	BAT2	VO2	FREE	IGN	ECM	HL	Lo	HI	W	R	L	FREE	HO	BAT	UP	SIG	GND	BAT	IG	
ON	○	○	○	○	○	○	○	○	○	○	○	○	○	○	○	○	○	○	○	○	○
OFF	○	○	○	○	○	○	○	○	○	○	○	○	○	○	○	○	○	○	○	○	○

- Bl Black
- Y Yellow
- Bu Blue
- G Green
- R Red
- W White
- Br Brown
- O Orange
- Lb Light Blue
- Lg Light Green
- P Pink
- Gr Gray

TWO COLORED WIRE (EXAMPLE:YELLOW/RED)



---

**MEMO**

---



# INDEX

ACCESSORY SOCKET (AFTER '13 MODEL).....	21-26	ECM.....	4-49
AIR CLEANER.....	3-7	ECT SENSOR.....	4-52
AIR CLEANER HOUSING.....	7-13	ELECTRICAL SYSTEM LOCATION.....	21-2
ALTERNATOR/STARTER.....	14-4	EMISSION CONTROL SYSTEMS.....	1-35
AVERAGE FUEL MILEAGE (AFTER '13 MODEL) ..	21-15	ENGINE HANGER LINK.....	16-6
BATTERY.....	20-7	ENGINE IDLE SPEED.....	3-13
BATTERY BOX.....	2-27	ENGINE INSTALLATION.....	16-7
BODY COVER.....	2-24	ENGINE OIL.....	3-11
BODY PANEL LOCATIONS ('13 MODEL).....	2-4	ENGINE OIL STRAINER SCREEN.....	3-12
BODY PANEL LOCATIONS (AFTER '13 MODEL) ..	2-5	ENGINE REMOVAL.....	16-4
BODY PANEL REMOVAL CHART ('13 MODEL) ..	2-4	EVAP CANISTER (EXCEPT AFTER '13 MODEL CM TYPE).....	7-28
(AFTER '13 MODEL).....	2-5	EVAP PURGE CONTROL SOLENOID VALVE (EXCEPT AFTER '13 MODEL CM TYPE).....	7-27
BRAKE CALIPER.....	19-23	EVAPORATIVE EMISSION CONTROL SYSTEM (EXCEPT AFTER '13 MODEL CM TYPE).....	3-15
BRAKE FLUID.....	3-17	EXHAUST PIPE/MUFFLER.....	2-29
BRAKE FLUID REPLACEMENT/AIR BLEEDING.....	19-5	FINAL DRIVE OIL.....	3-16
BRAKE LIGHT SWITCH.....		FINAL REDUCTION BEARING REPLACEMENT.....	13-8
LIGHTS/METERS/SWITCHES.....	21-25	FINAL REDUCTION CASE ASSEMBLY.....	13-12
MAINTENANCE.....	3-20	FINAL REDUCTION CASE SEPARATION.....	13-6
BRAKE LOCK OPERATION.....	3-21	FINAL REDUCTION INSPECTION.....	13-6
BRAKE MASTER CYLINDER.....	19-12	FLOOR MAT.....	2-8
BRAKE PAD/DISC.....	19-10	FLOOR STEP.....	2-20
BRAKE SHOES/PADS WEAR.....	3-17	FORK.....	17-8
BRAKE SYSTEM.....	3-18	FRONT COVER.....	2-16
CABLE & HARNESS ROUTING ('13 MODEL).....	1-19	FRONT FENDER.....	2-6
CABLE & HARNESS ROUTING.....		FRONT GRILLE.....	2-6
(AFTER '13 MODEL).....	1-25	FRONT LOWER COVER.....	2-18
CAM CHAIN TENSIONER LIFTER.....	10-23	FRONT METER PANEL.....	2-8
CAMSHAFT.....	10-8	FRONT WHEEL.....	17-6
CBS MASTER CYLINDER.....	19-16	FUEL GAUGE (AFTER '13 MODEL).....	21-15
CENTER COVER.....	2-11	FUEL INJECTOR.....	7-24
CENTERSTAND.....	2-29	FUEL LINE.....	3-6
CHARGING SYSTEM.....	20-8	FUEL LINE INSPECTION.....	7-6
CLUTCH SHOES WEAR.....	3-23	FUEL METER/FUEL LEVEL SENSOR.....	21-19
CLUTCH/DRIVEN PULLEY.....	12-12	FUEL PUMP UNIT.....	7-10
COMBINATION LIGHT (AFTER '13 MODEL).....	21-7	FUEL SUPPLY TEST (AFTER '13 MODEL).....	7-9
COMBINATION METER (AFTER '13 MODEL).....	21-12	FUEL TANK.....	7-13
COMPONENT LOCATION.....		GRAB RAIL.....	2-22
ALTERNATOR/STARTER.....	14-2	GRAB RAIL COVER.....	2-21
CRANKCASE/CRANKSHAFT.....	15-2	HANDLEBAR.....	17-17
CYLINDER HEAD/VALVES.....	10-2	HANDLEBAR FRONT COVER.....	2-15
CYLINDER/PISTON.....	11-2	HANDLEBAR POST.....	17-23
DRIVE PULLEY/DRIVEN PULLEY/CLUTCH.....	12-2	HANDLEBAR SWITCHES.....	21-24
ENGINE REMOVAL/INSTALLATION.....	16-2	HEADLIGHT ('13 MODEL).....	21-6
FINAL REDUCTION.....	13-2	HEADLIGHT AIM.....	3-22
FRONT WHEEL/SUSPENSION/STEERING.....	17-2	HORN.....	21-25
FUEL SYSTEM.....	7-2	IACV.....	7-22
HYDRAULIC BRAKE.....	19-2	IGNITION COIL.....	5-7
REAR WHEEL/BRAKE/SUSPENSION.....	18-2	IGNITION SWITCH.....	21-21
COOLANT REPLACEMENT.....	9-5	IGNITION SYSTEM INSPECTION.....	5-6
COOLANT TEMPERATURE INDICATOR.....	21-18	IGNITION TIMING.....	5-7
COOLING SYSTEM.....	3-14	INNER COVER.....	2-14
COOLING SYSTEM TESTING.....	9-4	INTAKE PIPE.....	7-25
CRANKCASE ASSEMBLY.....	15-8	LED CONTROL UNIT (AFTER '13 MODEL).....	21-28
CRANKCASE BREATHER.....	3-8	LEFT CRANKCASE COVER.....	12-6
CRANKCASE SEPARATION.....	15-5	LEFT INNER OUTER COVER (AFTER '13 MODEL) ..	2-13
CRANKSHAFT INSPECTION.....	15-7	LICENSE LIGHT.....	21-9
CYLINDER.....	11-5	LUBRICATION & SEAL POINTS.....	1-17
CYLINDER COMPRESSION TEST.....	10-6	LUBRICATION SYSTEM DIAGRAM.....	8-2
CYLINDER HEAD.....	10-13	LUGGAGE BOX.....	2-26
CYLINDER HEAD COVER.....	10-6	MAIN RELAY.....	21-27
DRIVE BELT.....		MAINTENANCE SCHEDULE ('13 MODEL).....	3-4
DRIVE PULLEY/DRIVEN PULLEY/CLUTCH.....	12-8	MAINTENANCE SCHEDULE (AFTER '13 MODEL).....	3-5
MAINTENANCE.....	3-15	METER PANEL COVER ('13 MODEL).....	2-12
DRIVE PULLEY.....	12-9	METER VISOR.....	2-7
DTC INDEX ('13 MODEL).....	4-15	MIL CIRCUIT INSPECTION ('13 MODEL).....	4-47
DTC INDEX (AFTER '13 MODEL).....	4-16	MIL CIRCUIT INSPECTION (AFTER '13 MODEL) ..	4-48
DTC TROUBLESHOOTING ('13 MODEL).....	4-17		
DTC TROUBLESHOOTING (AFTER '13 MODEL) ..	4-34		

# INDEX

MODEL IDENTIFICATION	1-3	REAR WHEEL/BRAKE/SUSPENSION	18-3
NUTS, BOLTS, FASTENERS	3-24	SERVICE RULES	1-2
O <sub>2</sub> SENSOR	4-53	SIDE COVER	2-9
OIL PUMP	8-5	SIDESTAND	3-23
PGM-FI CONNECTOR LOCATION ('13 MODEL)	4-9	SIDESTAND SWITCH	6-13
PGM-FI SYMPTOM TROUBLESHOOTING ('13 MODEL)	4-7	SPARK PLUG	3-9
PGM-FI SYMPTOM TROUBLESHOOTING (AFTER '13 MODEL)	4-8	SPECIFICATIONS	1-6
PGM-FI SYSTEM DIAGRAM	4-4	SPEEDOMETER ('13 MODEL)	21-10
PGM-FI SYSTEM LOCATION	4-2	STARTER SYSTEM INSPECTION	6-11
PGM-FI TROUBLESHOOTING INFORMATION ('13 MODEL)	4-10	STARTER/CHARGING RELAY	6-8
PGM-FI TROUBLESHOOTING INFORMATION (AFTER '13 MODEL)	4-13	STEERING HEAD BEARINGS	3-25
PISTON	11-7	STEERING STEM	17-24
PLUG MAINTENANCE LID	2-19	SUSPENSION	3-23
RADIATOR	9-6	SYSTEM DIAGRAM	
RADIATOR COOLANT	3-13	BATTERY/CHARGING SYSTEM	20-3
RADIATOR RESERVE TANK	9-7	ELECTRIC STARTER	6-3
REAR DRUM BRAKE	18-8	IGNITION SYSTEM	5-3
REAR FENDER	2-28	SYSTEM FLOW PATTERN	9-2
REAR METER PANEL	2-15	SYSTEM LOCATION	
REAR SHOCK ABSORBER	18-12	BATTERY/CHARGING SYSTEM	20-2
REAR WHEEL/SWINGARM	18-5	ELECTRIC STARTER	6-2
RIGHT INNER MAINTENANCE LID ('13 MODEL)	2-12	IGNITION SYSTEM	5-2
RIGHT INNER OUTER COVER (AFTER '13 MODEL)	2-13	TAIL/BRAKE LIGHT ('13 MODEL)	21-8
SEAT	2-11	TECHNICAL FEATURE (AFTER '13 MODEL)	1-34
SENSOR UNIT POWER LINE INSPECTION (AFTER '13 MODEL)	4-33	THROTTLE BODY	7-15
SERVICE INFORMATION		THROTTLE OPERATION	3-6
ALTERNATOR/STARTER	14-3	TORQUE VALUES	1-11
BATTERY/CHARGING SYSTEM	20-4	TROUBLESHOOTING	
COOLING SYSTEM	9-3	BATTERY/CHARGING SYSTEM	20-6
CRANKCASE/CRANKSHAFT	15-3	COOLING SYSTEM	9-3
CYLINDER HEAD/VALVES	10-3	CRANKCASE/CRANKSHAFT	15-4
CYLINDER/PISTON	11-3	CYLINDER HEAD/VALVES	10-5
DRIVE PULLEY/DRIVEN PULLEY/CLUTCH	12-3	CYLINDER/PISTON	11-4
ELECTRIC STARTER	6-4	DRIVE PULLEY/DRIVEN PULLEY/CLUTCH	12-5
ENGINE REMOVAL/INSTALLATION	16-3	ELECTRIC STARTER	6-5
FINAL REDUCTION	13-3	FINAL REDUCTION	13-5
FRAME/BODY PANELS/EXHAUST SYSTEM	2-3	FRAME/BODY PANELS/EXHAUST SYSTEM	2-3
FRONT WHEEL/SUSPENSION/STEERING	17-3	FRONT WHEEL/SUSPENSION/STEERING	17-5
FUEL SYSTEM	7-4	HYDRAULIC BRAKE	19-4
HYDRAULIC BRAKE	19-3	IGNITION SYSTEM	5-5
IGNITION SYSTEM	5-4	LUBRICATION SYSTEM	8-4
LIGHTS/METERS/SWITCHES	21-4	REAR WHEEL/BRAKE/SUSPENSION	18-4
LUBRICATION SYSTEM	8-3	TURN SIGNAL LIGHT ('13 MODEL)	21-7
MAINTENANCE	3-2	TURN SIGNAL LIGHT RELAY ('13 MODEL)	21-28
PGM-FI SYSTEM	4-6	UNDER COVER	2-10
		VALVE CLEARANCE	3-10
		VS SENSOR	21-16
		WATER PUMP/THERMOSTAT	9-8
		WHEELS/TIRES	3-24
		WIRING DIAGRAM ('13 MODEL)	22-2
		WIRING DIAGRAM (AFTER '13 MODEL)	22-3